

Rogue Valley

Stormwater Quality Design Manual



2023

Rogue Valley Stormwater Quality Design Manual

Adopted by:

City of Ashland

City of Central Point

City of Medford

Rogue Valley Sewer Services: serving

City of Phoenix

City of Talent

Jackson County

Prepared by the Stormwater Advisory Team Post-Construction Working Group:

Alena Beltz, City of Medford

James Philp, Jackson County

Jennie Morgan, Rogue Valley Sewer Services

Mike Ono, City of Central Point

Nick Bakke, Rogue Valley Sewer Services

Tyler Duncan, RH2

Acknowledgements:

Ben Wewerka, DOWL

Carl Tappert, Rogue Valley Sewer Services

Michael Ribeiro, City of Medford

Roger Thom, ODOT

Table of Contents

Chapter 1 – Introduction and General Information

1.1	INTRODUCTION	1-1
1.2	MANUAL OBJECTIVES.....	1-1
1.3	JURISDICTIONS ADOPTING THE DESIGN MANUAL	1-2
1.4	AUTHORITY.....	1-3
1.5	DESIGN MANUAL APPLICABILITY	1-3
1.6	RELATIONSHIP TO OTHER REQUIREMENTS AND STANDARDS	1-3
1.7	REVISION AND AMENDMENT PROCESS.....	1-3

Chapter 2 – Water Quality and Peak Flow Control Requirements

2.1	INTRODUCTION.....	2-1
2.2	RETENTION REQUIREMENTS.....	2-1
2.2.1	Retention Design Storm	2-1
2.2.2	Retention Exemptions.....	2-2
2.3	TREATMENT REQUIREMENTS	2-2
2.3.1	Treatment Design Storm.....	2-2
2.3.2	Treatment Exemptions.....	2-2
2.3.3	Pollutant Parameters	2-2
2.4	WATER QUALITY REQUIREMENTS: RETENTION AND TREATMENT.....	2-3
2.4.1	Design Storms	2-3
2.4.2	Mitigation Alternatives	2-3
2.4.3	Retention Requirement Technical Infeasibility Criteria.....	2-5
2.5	PEAK FLOW CONTROL: DETENTION STANDARDS	2-6
2.5.1	Detention Design Storms	2-6
2.6	Exemptions from Retention, Treatment and Detention.....	2-7
2.7	OPERATION AND MAINTENANCE REQUIREMENTS	2-7
2.8	PROJECT PLANNING, FACILITY AND APPROACH SELECTION.....	2-7
2.8.1	Approach Selection	2-8
2.9	Credits	2-9

Chapter 3 – Simplified Approach Structural Stormwater Controls (BMPs) and Design Standards

3.1	APPLICABILITY	3-1
3.2	APPROVED SIMPLIFIED APPROACH BMPs	3-1

3.2.1 Ponded Retention (Rain Garden/ Retention Ponds or Stormwater Planters).....	3-1
3.2.2 Pervious Surface Retention.....	3-3
3.2.3 Dispersion (Vegetated Filter Strips).....	3-3
3.2.4 Dispersion (Disconnected Downspouts to Pervious Area or Infiltration Trench).....	3-6

Chapter 4 – Performance Approach Structural Stormwater Controls (BMPs) and Design Standards

4.1 INTRODUCTION.....	4-1
4.2 GENERAL HYDROLOGIC CALCULATION CRITERIA.....	4-1
4.3 GENERAL SITING, GEOMETRIC, AND MATERIAL DESIGN STANDARDS.....	4-2
4.3.1 General BMP Design Standards: Retention.....	4-2
4.3.2 General BMP Design Standards: All Facilities.....	4-3
4.4 RETENTION BMPS.....	4-8
4.4.1 Ponded Retention BMP (Rain Garden/ Retention Ponds and Stormwater Planters).....	4-8
4.4.2 Pervious Surface Retention BMP.....	4-10
4.4.3 Underground Retention BMP.....	4-12
4.5 TREATMENT BMPS.....	4-13
4.5.1 Soil Filtration BMP (Rain Gardens and Stormwater Planters with Underdrains).....	4-13
4.5.2 Water Quality Swale BMP.....	4-14
4.5.3 Dispersion BMP (Vegetated Filter Strips & Disconnected Downspouts).....	4-15
4.5.4 Water Quality Settling Basin BMP (formerly Extended Detention).....	4-18
4.5.5 Proprietary Treatment BMP.....	4-19
4.5.6 Vegetated Roof BMP.....	4-21
4.6 DETENTION BMP (FLOW CONTROL).....	4-22

Chapter 5 - Stormwater Facility Maintenance and Operation Requirements

5.1 OPERATION AND MAINTENANCE ENFORCEMENT.....	5-1
5.2 REVISIONS TO APPROVED STORMWATER FACILITY.....	5-1
5.3 REMOVAL OF STORMWATER FACILITY DUE TO REDEVELOPMENT.....	5-1
5.4 POLLUTION PREVENTION/SPILL RESPONSE.....	5-1
5.5 OPERATION AND MAINTENANCE MANUAL CONTENTS.....	5-1

Chapter 6 – Performance Approach Submittal Requirements

6.1 INTRODUCTION.....	6-1
6.2 PLAN REQUIREMENTS.....	6-1
6.3 LANDSCAPE SUBMITTAL REQUIREMENTS.....	6-2
6.4 STORMWATER CALCULATION REPORT.....	6-2

6.5	PROPRIETARY SYSTEMS	6-3
6.6	OPERATIONS AND MAINTENANCE PLAN	6-4
6.7	STORMWATER FACILITY EASEMENT	6-4

Definitions

Tables

Table 1.1	Design Manual Applicability for Development or Redevelopment.....	1-3
Table 2.1	Allowed Design Approach, Standards, and Green Infrastructure Applicability	2-8
Table 4.1	Soil Gradation Requirements	4-5
Table 4.2	Plant Number and Spacing Requirements for Herbaceous Plants and Shrubs Mix.....	4-6
Table 4.3	Plant Number and Spacing Requirements for Herbaceous Plants, Small and Large Shrubs	4-6
Table 4.4	Tree Density Recommendations	4-7
Table 4.5	Vegetated Filter Strip Treatment Capacity vs. Design Slope	4-17

Figures

Figure 1.1.	MS4 Permittees Map	1-2
Figure 2.1.	Flow Chart Determining Management Requirements for Development or Redevelopment	2-4
Figure 2.2.	Required Separation Distance from Seasonal High Groundwater or Bedrock	2-5
Figure 3.1.	Above-Ground Stormwater Planter	3-1
Figure 3.2.	Stormwater Planter.....	3-2
Figure 3.3	Pervious Surface Not Intended for Vehicle Use.....	3-3
Figure 3.4	Vegetated Filter Strip	3-4
Figure 3.5	Schematic of a Vegetated Filter Strip	3-5

Figure 3.5 Disconnected Downspout Discharging to Pervious Area.....	3-5
Figure 3.6 Schematic of Disconnected Downspout Discharging to Infiltration Trench	3-6
Figure 3.7 Schematic of a Disconnected Downspout discharging to an infiltration trench.	3-6
Figure 4.1 Established Rain Garden on Commercial Lot.....	4-8
Figure 4.2 Single Basin In Ground Stormwater Planter and In-Ground Planter with Separate Cells	4-9
Figure 4.3 Permeable Pavers with Catch Basin.....	4-10
Figure 4.4 Underground Retention Chambers.....	4-12
Figure 4.5 Above-Ground Stormwater Planters	4-13
Figure 4.6 Water Quality Swale with Dense Mature Vegetation.....	4-14
Figure 4.7 Schematic of Vegetated Filter Strip	4-15
Figure 4.8 Vegetated Filter Strip General Layout Along Roadway.....	4-16
Figure 4.9 Disconnected Downspout to Pervious Surface	4-17
Figure 4-10 Extended Detention Basin with Vegetated Baffle System.....	4-18
Figure 4.11 Proprietary Treatment Devices with Filterra Units.....	4-19
Figure 4.12 Vegetated Roof Example.....	4-21
Figure 4.13 Detention Basin.....	4-22

Appendices

- Appendix A Infiltration Testing Methodology
Falling Head Test Report Form
- Appendix B Simplified Approach Procedure and Details
- Appendix C Santa Barbara Urban Hydrograph Spreadsheet Example
SBUH Excel spreadsheet for download
- Appendix D NRCS Table of Curve Numbers and Time of Concentration Calculation
Medford IDF Curves
- Appendix E Plant Specifications
Plant Material Source List
- Appendix F Standard Drawings Index
General Construction Notes and Material Specifications
PDF Standard Drawings
DWG Standard Drawings
- Appendix G SWAT Pre-Approved Proprietary SW Treatment Technologies
- Appendix H Stormwater Operation and Maintenance Plan Templates
O&M Manual Template (fillable pdf)
Section B: RVSS Declaration of Covenants
Medford Declaration of Covenants
Section D: Medford Subdivision O&M Agreement
Section F: SW Facility Inspection and Maintenance Checklists
- Appendix I RVSS Stormwater Credits

Abbreviations

BMPs	Best Management Practices
CEG	Certified Engineering Geologist
CN	Curve number
CULD	Conditional Use Level Designation
DEQ	Oregon Department of Environmental Quality
DoC	Declaration of Covenants
EPDM	Ethylene Propylene Diene Terpolymer
GRP	Green Roof Professional
GULD	General Use Level Designation
HDPE	High Density Polyethylene
IA	Impervious Area
IPM	Integrated pest management
MS4	Municipal Separate Storm Sewer System
NPSO	Native Plant Society of Oregon
NRCS	Natural Resources Conservation Service
NWCB	Noxious Weed Control Board
O&M	Operation and Maintenance
ODOT	Oregon Department of Transportation
PA	Pervious Area
PE	Professional Engineer
PNW	Pacific Northwest
RA	Roof Area
RVSS	Rogue Valley Sewer Service's
SBUH	Santa Barbara Urban Hydrograph
SF	Square Feet
SLOPES	Standard Local Operating Procedures for Endangered Species
SW	Stormwater
SWAT	Stormwater Advisory Team
SWF	Stormwater Facility
SWMPs	Stormwater Management Programs
TAPE	Technology Assessment Protocol- Ecology
TMDL	Total Maximum Daily Load
TSS	Total Suspended Solids
UIC	Underground Injection Control

Chapter 1 – Introduction and General Information

1.1 INTRODUCTION

Managing stormwater is an essential part of maintaining livability in an urban area. Urbanization results in vegetation removal, soil compaction, and impervious surface creation. Impervious surfaces collect precipitation, often increasing the temperature and amount of pollutants, from which runoff is quickly discharged into the closest water body. The quality, quantity, and rate of stormwater discharged can detrimentally impact aquatic ecosystems, drinking water quality, and recreation opportunities. Stormwater management attempts to mitigate these impacts by removing pollutants from runoff and reducing the quantity and rate of runoff.

To address impacts of urbanization on water quality, [Municipal Separate Storm Sewer System \(MS4\) Phase II permits](#) have been issued to urbanized jurisdictions (Permittees) in the Rogue Valley by the Oregon Department of Environmental Quality (DEQ). Permittees are required to develop Stormwater Management Programs (SWMPs) to reduce discharges of pollutants and address stormwater runoff from new and redevelopment projects that meet or exceed impervious area thresholds set by DEQ. The Permittee developed SWMPs must also include requirements for Permittee review and inspection of stormwater management plans for new and redevelopment projects. Permittees must submit their SWMPs to DEQ for review and approval and must report to DEQ annually on the implementation of the SWMPs.

The Rogue Valley Stormwater Design Manual (Design Manual) was jointly developed by jurisdictions in the Rogue Valley. This Design Manual was created to establish stormwater management standards and facilitate the design, review, and implementation of stormwater management facilities compulsory for site development. The requirements described herein were developed in accordance with DEQ's MS4 Phase II General Permit effective March 2019, and are based on local climatology, geography, soils, and other regional conditions.

1.2 MANUAL OBJECTIVES

For the purposes of the Design Manual, Stormwater Management is Retention, Treatment, and Detention of site runoff. The purpose of this Design Manual is to establish stormwater management standards to satisfy local development ordinances and the Post-Construction Stormwater Management Requirements (Schedule A.3.e) of the MS4 Phase II permit. Numeric stormwater management requirements were developed for this Design Manual that target predevelopment hydrologic function and meet the intent of the MS4 permit. More specifically, this Design Manual intends to:

- 1) Establish stormwater management standards for public and private developments in the Rogue Valley;
- 2) Identify Best Management Practices (BMPs) that meet Retention, Treatment, and Detention standards;
- 3) Describe Operation and Maintenance Requirements for BMPs; and,
- 4) Establish submission criteria for stormwater management plans.

1.3 JURISDICTIONS ADOPTING THE DESIGN MANUAL

The Design Manual is a regional manual, first implemented in 2006, that has been adopted by many MS4 jurisdictions within the Rogue Valley. Rogue Valley Sewer Service's (RVSS) [service map](#), linked here shows the boundaries of the MS4 jurisdictions. The jurisdictions that formally adopt the Design Manual become voting members of the Stormwater Advisory Team (SWAT), which oversees development of the Design Manual. As of the publication date, the Design Manual was adopted by the following jurisdictions: City of Ashland, City of Central Point, City of Medford, and RVSS (Figure 1.1). RVSS holds the MS4 permit for the cities of Phoenix and Talent as well as the urbanized, unincorporated portions of Jackson County. Project designers will need to submit to the appropriate approving jurisdiction for compliance with the Design Manual.

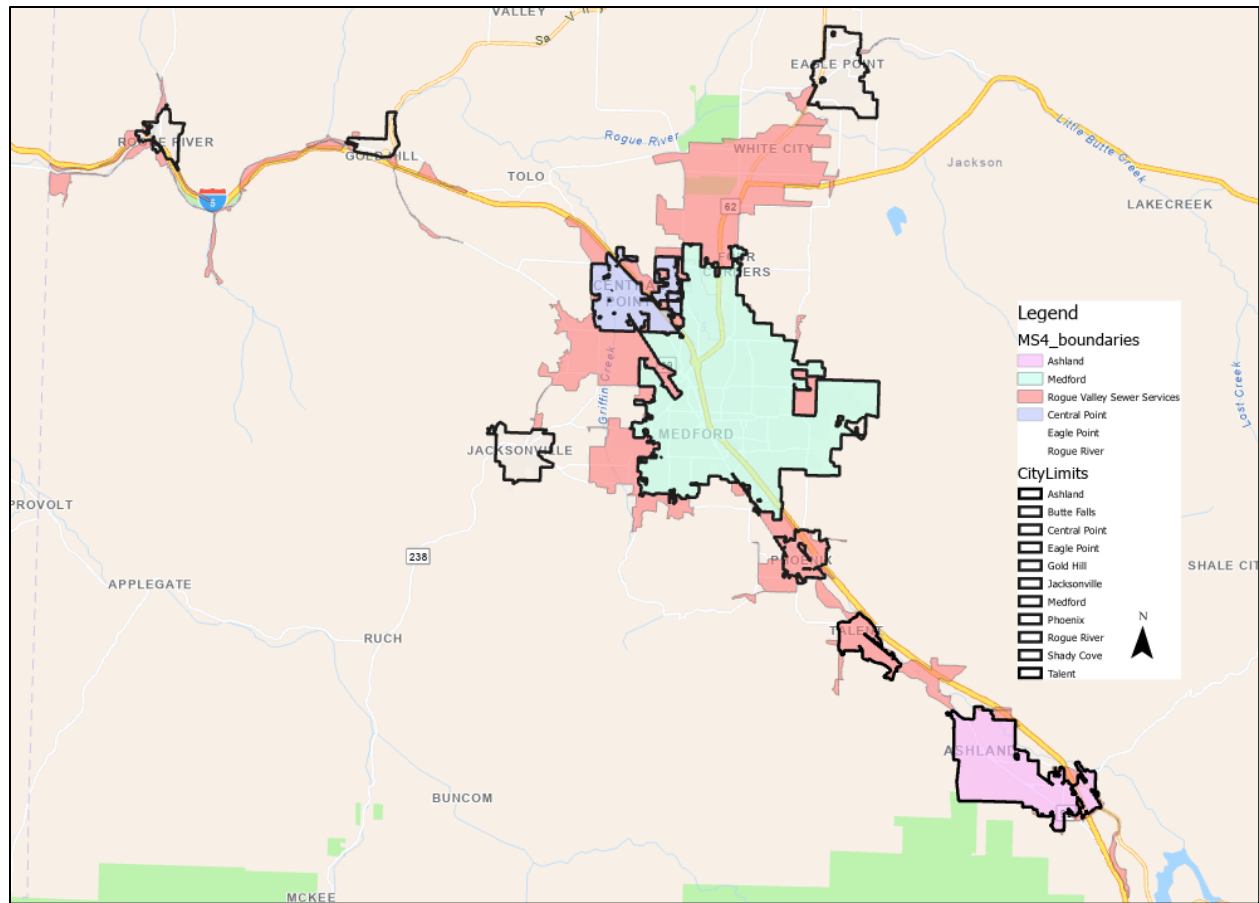

Figure 1.1. MS4 Permittees that have adopted the Rogue Valley Stormwater Quality Design Manual, at the time of this issuance, are shown in shaded colors.

Initial drafting of the Design Manual began in 2004, when DEQ advised communities that they would soon be required to comply with MS4 permits. The Design Manual has been amended many times since 2006 to clarify and provide better guidance to designers. A revised Design Manual was issued in 2018 with completely updated design details and standard drawings for each of the BMPs. In 2019, a new MS4 permit became effective that included many new requirements for post-construction stormwater management, necessitating revisions to the design storms and a new edition of the Design Manual.

1.4 AUTHORITY

Authority for the requirements in this Design Manual come from the MS4 permit, as well as the applicable development ordinances and codes of the municipalities and RVSS that have adopted this Design Manual.

1.5 DESIGN MANUAL APPLICABILITY

The requirements of this Design Manual apply to Development and Redevelopment, within the limits of any jurisdiction that has adopted the manual. The thresholds are outlined in Table 1.1.

Table 1.1 Design Manual applicability for Development or Redevelopment.

Location	Impervious Surface Area	Requirements
Within city limits	< 5,000 sf	None from this Design Manual
	≥ 5,000 sf	Retention and/ or Treatment
	≥ 10,000 sf	Detention
Outside city limits but inside MS4	≥ 10,890 sf	Retention and/ or Treatment and Detention*

* No Detention within the White City Residential boundary, see [RVSS' website](#).

1.6 RELATIONSHIP TO OTHER REQUIREMENTS AND STANDARDS

Projects may also need to comply with other requirements established by local, state or federal agencies. It is the responsibility of the project designer to ensure all applicable requirements are met and to resolve potential conflicts. The following are local requirements that may apply:

- Bear Creek and the Rogue River both have water quality that does not meet state water quality standards. To work toward improvement, DEQ has established [Total Maximum Daily Loads \(TMDLs\)](#) that stipulate the amount of pollution that can be contributed to the water bodies. Each jurisdiction that discharges into the water bodies is required to develop a TMDL Implementation Plan to address the pollution; a large number of required TMDL plan elements relate to post-construction stormwater management, and are addressed by this manual, or local codes.
- Riparian ordinances established by local jurisdictions.
- Construction activities must follow local jurisdiction ordinances and may require obtainment of erosion prevention and sediment control permits.
- Drainage, planning, and design ordinances established by local jurisdictions.
- Design standards for conveyance systems are not included in this Design Manual, refer to the local jurisdiction for these requirements.

1.7 REVISION AND AMENDMENT PROCESS

The SWAT is the approving body for any revisions to the Design Manual. Typically, the SWAT attempts to approve necessary minor amendments once a year and have them go into effect on July 1. Larger revisions to the Design Manual are undertaken as required by the MS4 permit, developed through a working group, and brought to the SWAT for approval. All proposed changes to the Design Manual are required to be noticed to the SWAT for 30 days prior to a vote. The public may attend SWAT meetings and provide comment on proposals but does not vote.

Chapter 2 – Water Quality and Peak Flow Control Requirements

2.1 INTRODUCTION

The MS4 Phase II permit requires permittees to “...establish a Site Performance Standard with a numeric stormwater retention requirement to target natural surface or predevelopment hydrologic function to retain rainfall on-site and minimize the offsite discharge of precipitation utilizing stormwater controls that infiltrate, capture and/or evapotranspire stormwater.” Based on these requirements, Retention of stormwater runoff using infiltration is the priority method of stormwater management and can be accomplished through the use of Low Impact Development or Green Infrastructure.

*“Low Impact Development (LID) is a stormwater management approach that seeks to mitigate the impacts of increased runoff and stormwater pollution using a set of planning, design and construction approaches and stormwater management practices that promote the use of natural systems for infiltration, evapotranspiration, and reuse of rainwater, and can occur at a wide range of landscape scales (i.e., regional, community and site). Low Impact Development is a comprehensive land planning and engineering design approach to stormwater management with a goal of mimicking the pre-development hydrologic regime of urban and developing watersheds”.*¹

*“Green Infrastructure is a specific type of stormwater control using vegetation, soils, and natural processes to manage stormwater, ... designed to mimic nature by reducing and/or storing stormwater through infiltration, evaporation and transpiration.”*²

Retention Facilities are designed to collect and hold site runoff to limit the volume of downstream discharge. The volume of downstream discharge from a Retention Facility may not exceed pre-developed levels and all runoff above the pre-developed runoff volume must leave the facility via infiltration, evapotranspiration, absorption by vegetation, or reuse on-site.

The MS4 Phase II permit also requires Permittees to establish Treatment standards. Treatment Facilities are designed to capture, filter and/or hold runoff for the length of time needed for suspended particles to settle out of the water column, runoff is then released downstream.

Local ordinance requires the implementation of peak flow control or Detention to attenuate the downstream impact of peak flow rates generated by an increase in impervious surfaces. Detention Facilities are designed to hold and release runoff at a rate no larger than the pre-developed peak runoff rate.

2.2 RETENTION REQUIREMENTS

Retention Facilities function based on the ability of water to infiltrate into the ground or evapotranspire into the atmosphere.

2.2.1 Retention Design Storm

Retention Facilities must be designed to Retain runoff from the 80th percentile storm event (0.46 inches). The 80th percentile rainfall event is the event with precipitation depth greater than or equal to the depth of 80% of all storm events over a given period. A 36-year period of record from 1984 to 2019 was examined using data from the Medford Airport WSO AP weather station to determine the 80th percentile event for the Rogue Valley.

¹ DEQ NPDES MS4 Phase II General Permit, March 2021.

² See Note 1.

2.2.2 Retention Exemptions

Many conditions, including geology and site location, may limit the ability of a Retention Facility to properly function at a site. Described in **Section 2.4.1** are technical criteria that this Design Manual acknowledges inhibit Retention, if any of these exist on the site, the site is considered infeasible for retention-based stormwater facilities. Technical justification must be provided in the form of a site-specific hydrologic or design analysis conducted or endorsed by an Oregon registered Professional Engineer (PE) or Oregon Certified Engineering Geologist (CEG) demonstrating that infeasibility factors exist on the site. The analysis must receive concurrence from the approving jurisdiction. If Retention is deemed infeasible for a site, Option 1.b (**Section 2.4**) treatment of the 95th percentile storm is still required.

2.3 TREATMENT REQUIREMENTS

Treatment Facilities are designed to remove total suspended solids (TSS) through filtration, infiltration, or settling of solids. Stormwater management facilities can be designed to achieve both Retention and Treatment, or a treatment train with multiple facilities may be utilized. Furthermore, when selecting a Treatment Facility, Green Infrastructure facilities must be considered first. Stormwater Facilities meeting Retention, Treatment and/or Green Infrastructure requirements are identified in **Table 2.1**.

2.3.1 Treatment Design Storm

Treatment Facilities must be designed to treat all runoff from the 95th percentile storm event (0.84 inches). The 95th percentile rainfall event is the event with precipitation depth greater than or equal to the depth of 95% of all storm events over a given period. A 36-year period of record from 1984 to 2019 was examined using data from the Medford Airport WSO AP weather station to determine the 95th percentile event for the Rogue Valley.

2.3.2 Treatment Exemptions

Refer to the Transportation paragraph in **Section 2.4.1** Retention Requirement Technical Infeasibility.

2.3.3 Pollutant Parameters

The Phase 2 MS4 permit requires a minimum removal of 80% of TSS from the treatment design storm. The facilities detailed in [Chapter 4](#) of this Design Manual are assumed to meet this TSS removal requirement. Any proposed alternative facility must meet or exceed this requirement.

2.4 WATER QUALITY REQUIREMENTS: RETENTION AND TREATMENT

Retention and Treatment requirements have been established for this Design Manual and can be met by satisfying either Option 1 or 2 below. The options are provided to allow flexibility on project sites. Option 1 has two parts; Retention and Treatment, while Option 2 only has Retention, but applies it to the entire runoff volume from newly developed and redeveloped areas. Detention requirements are covered in **Section 2.5** of this Design Manual.

2.4.1 Design Storms

- Retention Storm: 0.46 inches in 24 hours (80th percentile storm event)
- Treatment Storm: 0.84 inches in 24 hours (95th percentile storm event)

Choose Option 1 or Option 2

Option 1.

- a) Target natural surface or predevelopment hydrologic function by retaining all additional runoff volume generated by the Retention storm from post-developed site conditions when compared to pre-developed conditions. Refer to **Section 2.4.1** for a discussion of Technical Infeasibility Factors. If the approving jurisdiction concurs that the site is technically infeasible for Retention, only part 1.b. is required.

And,

- b) Treat all runoff generated by the Treatment storm from new and redeveloped impervious surfaces. Green Infrastructure must be prioritized as the treatment mechanism.

Or,

Option 2.

Retain 100% of the runoff volume generated by the Retention storm from newly developed and redeveloped areas. The Treatment requirement is considered satisfied with this option. Option 2 may not be used if claiming technical infeasibility for a project site.

2.4.2 Mitigation Alternatives

If neither Option 1 or Option 2 is technically feasible for the project site, designers may propose alternatives to the local jurisdiction to satisfy the Retention and Treatment standards.

FOR PROJECTS WITHIN CITY LIMITS

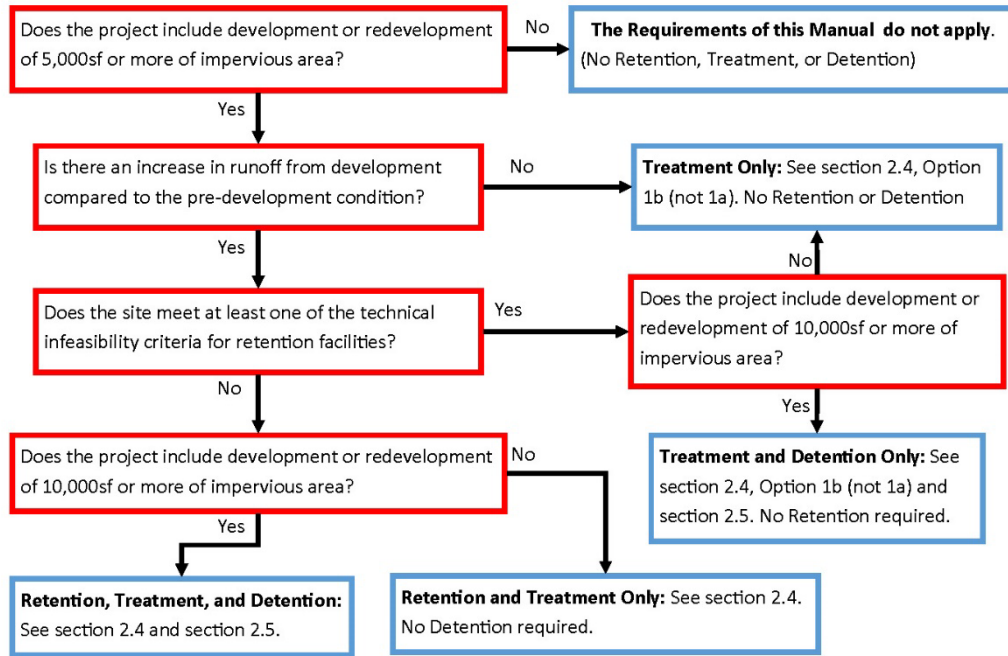

FOR PROJECTS OUTSIDE CITY LIMITS

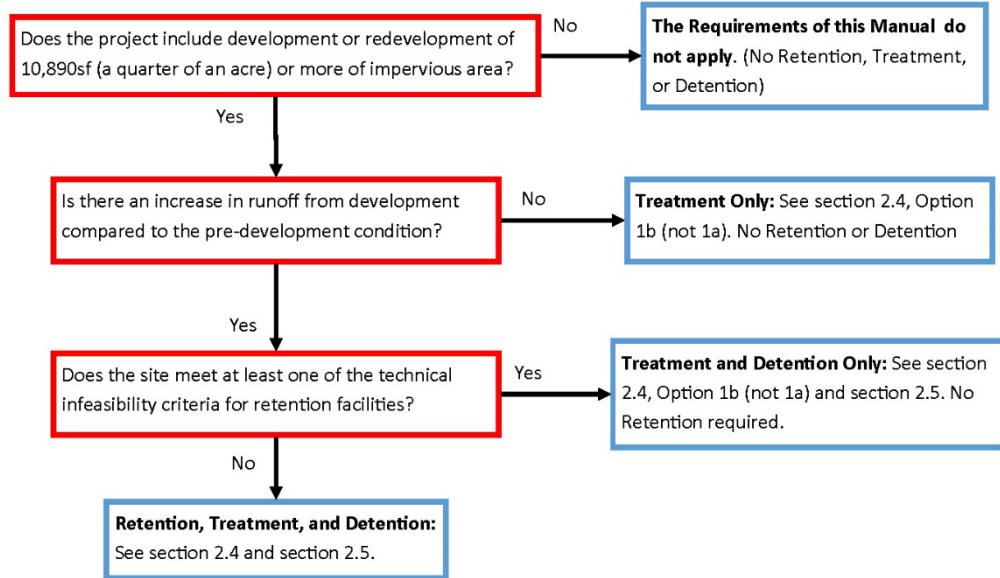

Figure 2.1. Flow chart used for determining Stormwater Management requirements for Development or Redevelopment.

2.4.3 Retention Requirement Technical Infeasibility Criteria

The factors discussed below make a site infeasible for Retention Facilities, if a site meets any of these infeasibility criteria, Option 1b must be followed.

Separation Distance from Seasonal High Groundwater and Bedrock

Depth to seasonal high groundwater and bedrock for design and determination of technical infeasibility for Retention shall utilize the best available information. Results of geotechnical investigations, well boring logs, observations during infiltration testing, and/or other site-specific studies are preferred. However, if such information is unavailable, use of the Natural Resources Conservation Service (NRCS) soil data, available via the web soil survey, is acceptable. The stormwater Calculation Report, prepared by an Oregon registered PE or CEG, shall include a discussion of the methodology and data sources used to determine depth to groundwater and/or bedrock. Separation distance shall be measured from stormwater facility subgrade as represented in **Figure 2.2**.

- 1) A separation distance of less than three feet exempts the following stormwater facilities from Retention:
 - a) Facilities that are not Underground Injection Controls (UICs) and do contain soil growth media,
 - b) Pervious paving receiving rainfall only.
- 2) A separation distance of less than five feet exempts the following facilities from Retention:
 - a) Stormwater facilities that do not have soil growth media;
 - b) Or pervious paving receiving run-on.

These facilities may be classified as UIC's by DEQ, refer to [DEQ's website](#) for the current UIC definition.

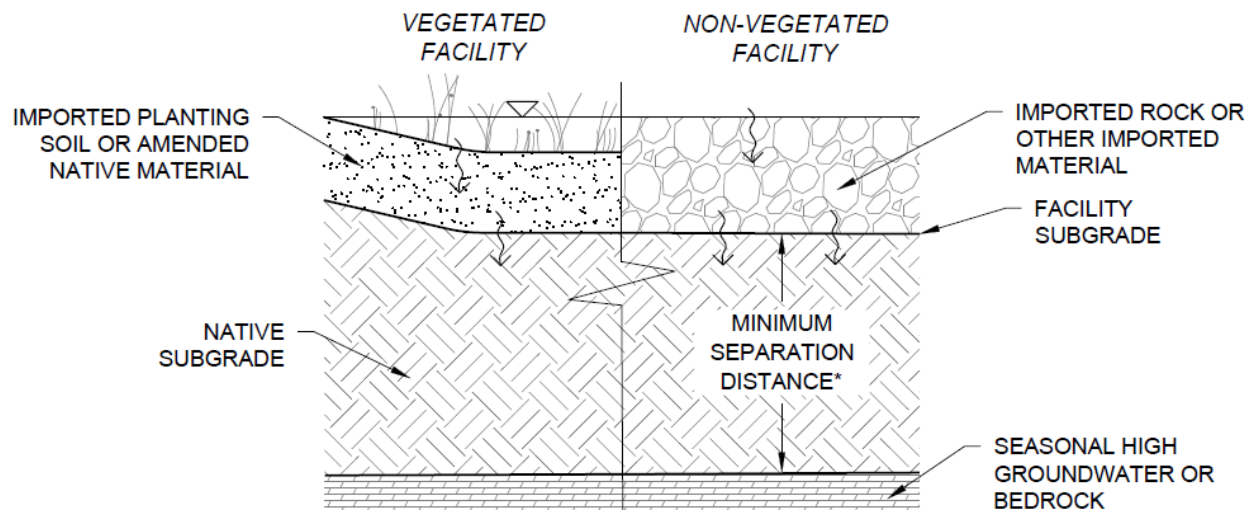

Figure 2.2 The required separation distance from seasonal high groundwater or bedrock should be measured as illustrated.

Steep Slopes

Slopes of 15% or more on average across the project site will exempt the site from the Retention requirements. Or, if an Oregon registered PE or CEG recommends the avoidance of infiltration on-site due to instability, then the site will be exempt from Retention requirements.

Distance to Drinking Water Wells

Sites will be exempt from Retention requirements if there is less than 500 feet of separation from a UIC to a drinking water well, or less than 50 feet of separation between a stormwater (SW) facility and a

drinking water well, with the exception of lined facilities. At the time of publication of this Design Manual, the separation distance required by DEQ between UICs and drinking water wells was 500 feet; however, designers should verify with DEQ that this is still the standard.

Land Use Planning

Jurisdictional planning requirements that make infiltration stormwater facilities infeasible are considered to make Retention infeasible. If intending to use this infeasibility criteria, the designer shall seek prior approval from the local jurisdiction.

Transportation

The following public and private transportation related projects are considered infeasible for Retention:

- Any project that would require the purchase of right-of-way for a Retention Facility.

Infiltration Rate

Sites with a Measured Infiltration Rate of 1.5 inches per hour or less are exempt from Retention requirements. Infiltration measurement shall follow the protocol outlined in **Appendix A**, or a protocol recommended by an Oregon registered PE or CEG.

Contaminated Soils

If DEQ has deemed that the project site has any contaminated soils, the project site will be infeasible for Retention.

Other Requirements

If other requirements are applied to the site, such as SLOPES (Standard Local Operating Procedures for Endangered Species), that may impact the ability to incorporate Retention, discuss these with the local jurisdiction prior to design.

2.5 PEAK FLOW CONTROL: DETENTION STANDARDS

Detention standards are intended to prevent an increase in peak flow runoff from a developing site in order to preserve the capacity in downstream storm drains and to prevent downstream erosion. Detention Facilities are required to be installed at the time of Development and must be sized so that the post-development peak flow is less than or equal to the pre-development peak flow for the 10-year event. Each Detention facility is required to have an overflow structure sized to accommodate the post-development peak flow for the 25-year event. Detention Facilities may be required to be designed to a different standard if the local jurisdiction is aware of reduced capacity downstream.

2.5.1 Detention Design Storms

- Peak Flow: 10-year event, 24-hour rainfall depth of 3.0 inches
- Overflow: 25-year event, 24-hour rainfall depth of 3.25 inches

2.6 EXEMPTIONS FROM RETENTION, TREATMENT AND DETENTION

Transportation

The following transportation activities are exempt from Retention, Treatment and Detention requirements:

- Repair of road base that does not concurrently expand the impervious surface greater than the applicable threshold from **Section 1.5**
- Widening less than a single lane for less than 1,000 linear feet,
- Shoulder additions that do not include installation of curb and/or gutter,
- Surface maintenance work, including dig outs, within the existing impervious footprint,
- Correcting substandard intersections, for reasons of function, capacity, or safety,
- Improving existing drainage systems,
- Emergency roadwork that occurs outside the normal Capital Improvement Process.

Bike and Pedestrian Improvement Projects in the following situations:

- Exclusive bike and pedestrian projects that do not include installation of curb and/or gutter,
- The bike and pedestrian portions of a larger project, that do not include installation of curb and/or gutter.

Utility Trenches

Utility trenches are exempt from Retention, Treatment and Detention requirements.

2.7 OPERATION AND MAINTENANCE REQUIREMENTS

Stormwater management facilities for Retention, Treatment, and Detention of stormwater runoff must be maintained in perpetuity. The designer shall discuss with the property owner the operation and maintenance requirements of any proposed Stormwater Management Facilities prior to choosing a facility. An Operation and Maintenance Manual must be prepared for all stormwater management facilities, in accordance with the requirements of [Chapter 5](#) and **Appendix H**, and be submitted to the approving jurisdiction for review and approval.

2.8 PROJECT PLANNING, FACILITY AND APPROACH SELECTION

Use of Green Infrastructure for stormwater management must be prioritized on all projects. **Table 2.1** identifies the type of stormwater facilities that are considered Green Infrastructure by this Design Manual. The basic steps below will help to characterize a site and determine applicable standards.

- 1) Evaluate the Site. Identify natural resources and trees that must be preserved, drainage patterns, and existing utilities.
- 2) Characterize Site Drainage. Evaluate drainage area, groundwater and bedrock depth, soil types, and conduct infiltration testing per **Appendix A**.
- 3) Consider:
 - a) Minimization of impervious surfaces through LID concepts such as reduced building footprints, efficient parking, and narrow streets,
 - b) Evapotranspiration through planting of trees and perennial vegetation,
 - c) Reuse of stormwater on-site.
 - d) Stormwater facilities must be operated and maintained in perpetuity, consider what will be required for maintenance. Refer to [Chapter 5](#) for a discussion of the required Operation and Maintenance Manual.
- 4) Determine Applicable Design Standards. Based on the new or redeveloped impervious square footage, and considering Retention technical infeasibility criteria, and any other exemptions, determine if stormwater facilities will need to provide Retention, Treatment, and or Detention.

- 5) Maximize Infiltration. To the extent feasible, locate stormwater facilities in areas with highly infiltrating soils. Integrate landscaping requirements with stormwater management facilities.
- 6) Select and Size Facilities. Utilize the approved design approaches described in this Design Manual.

2.8.1 Approach Selection

Approved structural stormwater management controls, hereafter referred to as Best Management Practices (BMPs), are provided in this Design Manual. Calculation and Design standards used to size and design BMPs in this Design Manual are approved by the SWAT and must be implemented to meet Water Quality (Retention and Treatment) and Peak Flow Control (Detention) requirements.

Two approaches are allowed by this Design Manual, Simplified and Performance. The Simplified Approach is allowed for some, generally smaller, facilities while the Performance Design Approach is acceptable for any BMP. The general methodology for each approach is outlined below. Once the required standards for a particular site are understood, and a design approach is selected, **Table 2.1** can be used to help choose appropriate stormwater facilities.

Table 2.1 Allowed design approach, standards and green infrastructure applicability.

BMP #	BMP Name	Design Approach		Can be Designed For:		
		Simplified	Performance	Retention	Treatment	Green Infrastructure
4.4.1	Ponded Retention (Rain Garden/ Retention Ponds, Stormwater Planters)	Y	Y	Y	Y	Y
4.4.2	Pervious Surface Retention	Y*	Y	Y	Y	N
4.4.3	Underground Retention	N	Y	Y	Y	N
4.5.1	Soil Filtration (Rain Gardens and Stormwater Planters with Underdrains)	N	Y	N	Y	Y
4.5.2	Water Quality Swale	N	Y	N	Y	Y
4.5.3	Dispersion (Vegetated Filter Strip)	Y	Y	N	Y	Y
4.5.3	Dispersion (Disconnected Downspout)	Y	N	N	Y	Y
4.5.4	Water Quality Settling Basin (Extended Detention formerly)	N	Y	N	Y	Y
4.5.5	Proprietary Treatment	N	Y	N	Y	N**
4.5.6	Vegetated Roof	N	Y	N	Y	Y
4.6	Detention (Flow Control)***	N	Y	N	N	N

*Only for non-vehicular pervious surfaces.

**If no soil filtration medium.

***Can be designed in combination with other facilities.

Simplified Approach

The Simplified Approach is intended to be a streamlined stormwater management approach for small projects and is not required to be performed by an Oregon registered PE or CEG. See [Chapter 3](#) for the implementation standards of this approach.

Simplified Approach allowed when:

- a) < 10,000 square feet of impervious surface Development or Redevelopment for the entire Project, and
- b) Contributing Drainage Area of an individual BMP < 10,000 square feet

Retention and Treatment requirements are assumed to be satisfied with the Simplified Approach. Detention requirements are independent of this approach and must be determined based on the total Developed and/or Redeveloped impervious surface of the site.

Even though this approach is allowed without a PE or CEG, there may be features of the project that would be best addressed by a PE or CEG to avoid negative results such as poor site drainage, high groundwater, flooding, or impacts to neighboring properties. Additionally, liability may exist for draining water onto an adjacent property or causing water to flood onto an adjacent property. The project manager and owner should assess these risks to determine whether a PE or CEG should be hired to develop a site design including a grading, drainage, and or utility plan. The PE or CEG would still be allowed to use the Simplified Approach, thus reducing the time and effort required to comply with the requirements of this Design Manual.

Performance Design Approach

The Performance approach is required for the design of BMPs with a Contributing Drainage Area of 10,000 square feet or more and may be utilized for the design of any BMP. This approach must utilize the calculation and design standards in [Chapter 4](#) and must be performed by an Oregon registered PE or CEG.

2.9 CREDITS

RVSS provides credits stormwater fees and incentive funding for projects that go above and beyond the requirements of this manual. See Appendix I for information on stormwater credits and visit [RVSS' website](#) for information on incentive funding.

Chapter 3 – Simplified Approach Structural Stormwater Controls (BMPs) and Design Standards

3.1 APPLICABILITY

The Simplified Approach is intended to be a streamlined stormwater management method for small projects to address Retention and Treatment. Implementation of this approach can be done by anyone (an Oregon registered Professional Engineer (PE), or an Oregon Certified Engineering Geologist (CEG) is not required).

Simplified Approach allowed when:

- < 10,000 square feet of impervious surface Development or Redevelopment for the entire Project
- Contributing Drainage Area of an individual BMP < 10,000 square

Even though this approach is allowed without an Oregon registered PE or an Oregon CEG, there may be features of the project that would be best addressed by a PE or CEG to avoid negative results such as poor site drainage, high groundwater, flooding, or impacts to neighboring properties. Additionally, liability may exist for draining water onto an adjacent property or causing water to flood onto an adjacent property. The project manager and owner should assess these risks to determine whether a PE or CEG should be hired to develop a site design including a grading, drainage, and/or utility plan. The PE or CEG would still be allowed to use the Simplified Approach, thus reducing the time and effort required to comply with the requirements of this Design Manual.

3.2 APPROVED SIMPLIFIED APPROACH BMPs

3.2.1 Ponded Retention (Rain Garden/ Retention Ponds or Stormwater Planters)

Rain Gardens impound stormwater runoff aboveground in low lying areas allowing the runoff to infiltrate into the existing subgrade.



Figure 3.1. Rain garden six months after planting.

Stormwater Planters may either be in-ground or aboveground and have vertical sides created by curbs, walls, or containers allowing the runoff to infiltrate into the existing subgrade.



Figure 3.2 Stormwater Planter.

Simplified Approach Requirements

- 1) Facility must be constructed per the applicable Standard Drawing in **Appendix B**.
- 2) Facility must be at least 10 feet from building foundations.
- 3) The post-developed Contributing Impervious Area must drain to the facility.
- 4) Bottom area must be 5% of the post-developed Contributing Impervious Area.

$$SWF A = IA \times SF$$

Where:

SWF A = Stormwater facility wetted area

IA = post-developed Contributing Impervious Area to be treated by the facility

SF = Sizing Factor of 0.05

Example: For a post-developed Contributing Impervious Area of 9,000 square feet, the wetted area of the facility shall be 450 square feet.

- 5) The overflow location must be identified on the site plan.

3.2.2 Pervious Surface Retention

Pervious surfaces (also known as permeable pavements and porous pavements) are stormwater management facilities that allow water to move through void spaces within the pavement surface and rock below and infiltrate into underlying soils.



Figure 3.3. Pervious surface not intended for vehicular use.

Simplified Approach Requirements

- 1) The surface should only receive direct rainfall, runoff from other areas cannot flow onto the pervious surface.
- 2) Pervious surface is not intended for vehicular use.
- 3) Pervious surface must be at least 10 feet away from building foundations.
- 4) Facility must be constructed per the applicable Standard Drawing in **Appendix B**.
- 5) If pavers are not themselves pervious, spacing between the pavers must be 20% of the overall surface area, per Standard Drawing 4.4.2.c.
- 6) Base rock and pavement thickness must be as recommended by the manufacturer.
- 7) General flow direction and off-site discharge locations must be shown on the site plan.

3.2.3 Dispersion (Vegetated Filter Strips)

Vegetated Filter Strips can be installed alongside impervious surfaces such as roadways, walkways, and patios. Vegetated filter strips run parallel to the impervious surface, are gently sloped away from the impervious surface, and must be completely vegetated to filter and reduce velocity as runoff flows through the facility.



Figure 3.4. A vegetated Filter Strip runs along the left side of this path.

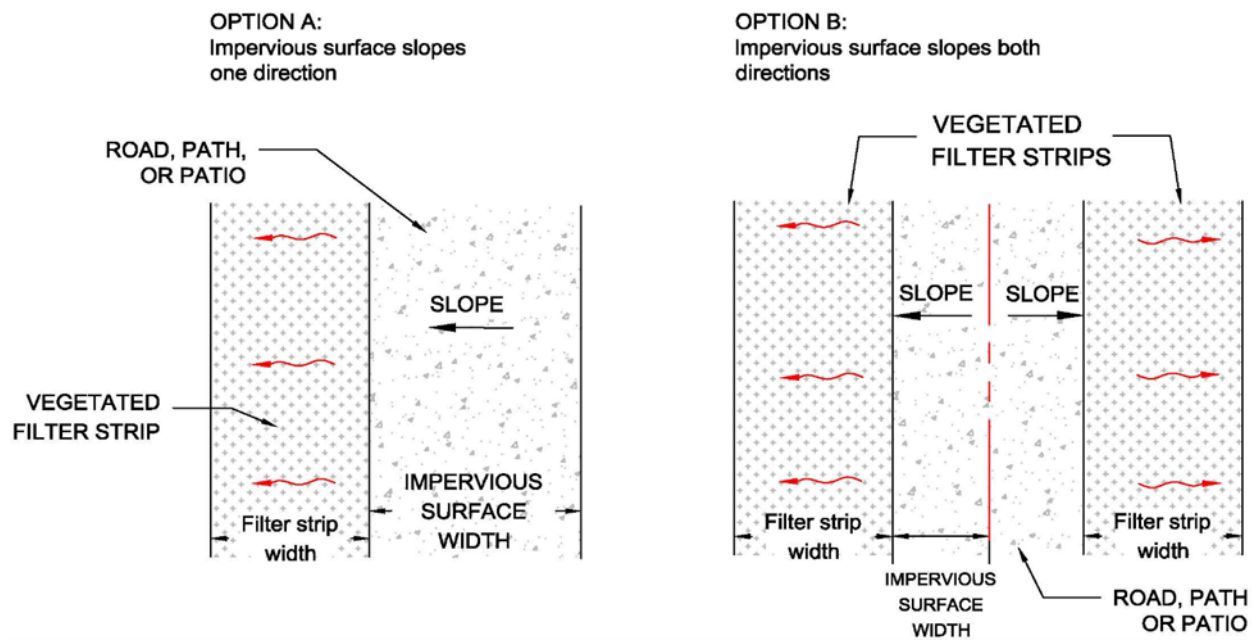

Figure 3.5. Schematic of a Vegetated Filter Strip.

Simplified Approach Requirements

- 1) Facility must be constructed per the applicable Standard Drawing in **Appendix B**.
- 2) Filter strip should not slope towards building foundations.
- 3) Impervious surface must slope towards the filter strip at a maximum slope of 5%.
- 4) Filter strip must slope away from the impervious surface with a maximum slope of 10%.
- 5) Maximum impervious surface “width” (see Figure 3.5) prior to entering the filter strip is 75 feet as measured along the cross-slope of the impervious surface draining towards the filter strip.
- 6) Maximum longitudinal slope of the impervious surface and filter strip is 4%.
- 7) Filter strip should be sized at a ratio of 1 foot of filter strip width for every 2 foot of impervious surface.

$$FS\ W = IS\ W \times SF$$

Where:

FS W = Filter strip width

IS W = Impervious surface width

SF = Sizing Factor of 0.5

Example: For an access road that is 10 feet wide, with a crown down the center of the road, the filter strips on each side of the road should each be at least 2.5 feet wide. Or, for an access road that is 10 feet wide, with the entire width sloping to one side (no crown), the filter strip should be at least 5 feet wide on one side.

- 8) The overflow location must be identified on the site plan.

3.2.4 Dispersion (Disconnected Downspouts to Pervious Area or Infiltration Trench)

Disconnected Downspouts to Pervious Area

Runoff is directed from downspouts or underground drain pipe to a pervious area in-lieu of discharging directly to a storm drain system.



Figure 3.6. A Disconnected Downspout discharging to a pervious area.

Disconnected Downspouts with an Infiltration Trench

Runoff is directed from downspouts or underground drain pipe to a trench filled with gravel for infiltration in-lieu of discharging directly to a storm drain system.

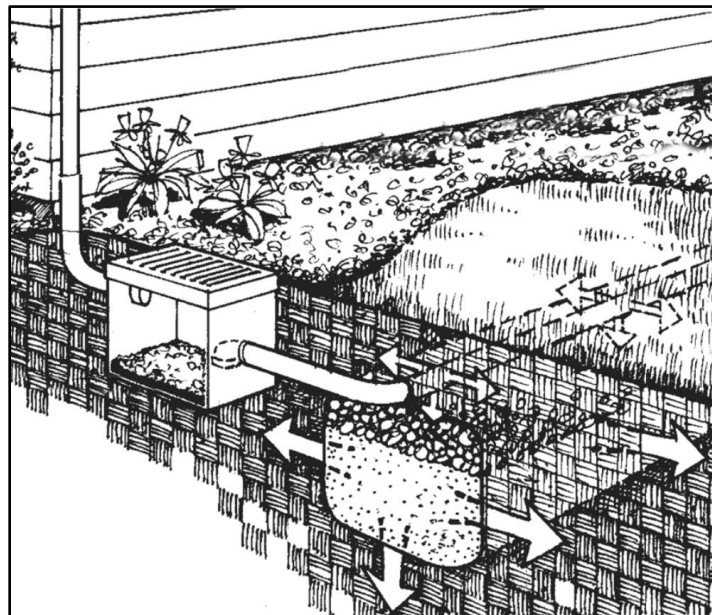

Figure 3.7. Schematic of a Disconnected Downspout discharging to an infiltration trench.

Simplified Approach Requirements – Disconnected Downspouts to Pervious Area:

- 1) Not allowed on lots where the average slope is greater than 10%.
- 2) Facility must be constructed per the applicable Standard Drawings in **Appendix B**.
- 3) Splash blocks or energy dissipation is required at the end of the downspout.

- 4) Downspout extensions may be installed above ground or underground. Aboveground downspout extensions must discharge a minimum of five feet from building foundations. Belowground downspout extensions must discharge a minimum of 10 feet from building foundations. If underground, a cleanout box should be added near the building.
- 5) Downspout discharge point cannot be less 10 feet from the property line.
- 6) Discharge from downspout may not flow over an impervious surface.
- 7) General flow direction and off-site discharge locations must be shown on the site plan.
- 8) Maximum Contributing Impervious Area is 700 square feet of roof per downspout.
- 9) Pervious flow path must slope away from the building between 2% and 5%.
- 10) Pervious area must be 5% of the Contributing Drainage Area (roof area).

$$PA = RA \times SF$$

Where:

PA = Pervious area

RA = Contributing Impervious Area (roof area)

SF = Sizing Factor of 0.05

Example: For a roof area that is 700 square feet, the disconnected downspout should discharge to a pervious area that is at least 35 square feet.

[Simplified Approach Requirements – Disconnected Downspouts to Infiltration Trench](#)

- 1) Not allowed on lots where the average slope is greater than 10%.
- 2) Facility must be constructed per the applicable Standard Drawings in **Appendix B**.
- 3) Downspouts must discharge into the infiltration trench a minimum of 10 feet from building foundations, and a cleanout box should be added near the building.
- 4) Infiltration trenches must be located more than 10 feet from the property line.
- 5) Maximum Contributing Impervious Area is 700 square feet of roof per downspout.
- 6) The infiltration trench should be 10 feet long, 2 feet wide, 18 inches deep, and be perpendicular to the slope (flat).
- 7) General flow direction and off-site discharge locations must be shown on the site plan.

Chapter 4 – Performance Approach Structural Stormwater Controls (BMPs) and Design Standards

4.1 INTRODUCTION

Chapter 4 focuses on calculation and design standards for approved BMPs. The standards in this chapter must be used when employing the Performance Design Approach outlined in [Chapter 2](#) to meet Retention, Treatment, and Detention requirements. The following points outline how the standards in this chapter are implemented:

- 1) One or multiple BMPs that provide Retention, Treatment, and Detention or a combination thereof may be incorporated at one location. For efficiency, these are referred to as Stormwater Management Facilities or SWFs in this manual.
- 2) All standards in this chapter shall apply as applicable to the design and construction of each SWF.
- 3) General Design Standards apply to all BMPs including Retention, Treatment, and Detention BMPs.
- 4) Standards specific to the design of Retention SWFs are separated from the General Design Standards and must be adhered to in the design of Retention facilities.
- 5) Design standards specific to individual BMPs are listed in the appropriate BMP section and shall govern in the case of a standard overlap or contradiction.
- 6) Alternative Retention, Treatment, or Detention systems not approved by this manual may be implemented on a case-by-case basis. However, alternative systems must comply with the applicable requirements in [Chapter 2](#) and the General Calculation and Design Standards in this chapter. Alternative system design and methodology must be submitted to and approved by the reviewing jurisdiction.

4.2 GENERAL HYDROLOGIC CALCULATION CRITERIA

This section outlines the methodology and parameters which are implemented for the design storms defined in [Chapter 2](#) to calculate runoff volume, storage, and peak flows.

Accepted Calculation Methodologies

Peak flow and runoff volume may be calculated using the Santa Barbara Urban Hydrograph Method (SBUH) (**Appendix C**), the Natural Resources Conservation Service (NRCS) Curve Number Method with a Type 1A rainfall distribution, or by any other method acceptable to the reviewing jurisdiction. Required storage volumes must be determined using hydrograph routing.

Contributing Drainage Area

Contributing Drainage Area is the total drainage area used to calculate peak flows and runoff volumes and includes all impervious and pervious surfaces which contribute runoff to a specific location. BMPs must be sized to accommodate all runoff from contributing drainage areas. Flows that are not required to be Retained, Treated, or Detained may be routed around a facility via a bypass structure and/or a bypass conveyance system. A contributing drainage area map must be submitted for all projects.

Time of Concentration

For the Pre-Development Hydrologic Function, the Time of Concentration is the time it takes for water to travel from the hydraulically most distant point of the drainage basin to the location where most runoff may leave the drainage basin. For the Post-Development Condition, the Time of Concentration is the time it takes for water to travel from the hydraulically most distant point of the drainage basin to the runoff location. The NRCS TR-55 method is preferred for calculation of the Time of Concentration.

Runoff CN

Runoff curve numbers (CNs) are used to categorize runoff potential based on soil type and land use. Curve numbers were developed by the NRCS and are published in the TR-55, **Table 2-2**, which is included in **Appendix D**. For the Pre-Development Condition, the CN(s) must be selected from the TR-55 **Table 2-2** and a statement must be provided in the stormwater report justifying how the CN applies to the site's Pre-Development Hydrologic Function, unless another method is approved by the local jurisdiction.

4.3 GENERAL SITING, GEOMETRIC, AND MATERIAL DESIGN STANDARDS

This section specifies general siting, geometric, and material standards, which are used along with peak flows and storage volumes to size and design all BMPs approved by this manual.

4.3.1 General BMP Design Standards: Retention

The following are general design standards that apply to facilities that provide Retention. Additional BMP specific design requirements are found in **Section 4.4** and must be followed.

- 1) **Retention Technical Infeasibility Criteria:** Retention facility design must comply with the Technical Infeasibility Criteria outlined in **Section 2.4.1**.
- 2) **Infiltration Testing:** Infiltration Testing is required for all sites. The Measured Infiltration Rate shall be determined based on infiltration testing procedures outlined in **Appendix A**, or by a protocol recommended by an Oregon registered PE or CEG.
- 3) **Design Infiltration Rates:** The Design Infiltration Rate shall be used in all calculations.
 - a) The minimum Measured Infiltration Rate for Retention facilities shall be per **Section 2.4.1**.
 - b) Design Infiltration Rates shall be determined by applying a minimum factor of safety of 3 to the Measured Infiltration Rate. An alternate factor of safety is allowed for the Pondered Retention BMP, see **Section 4.4.1**.
 - c) The Maximum Design Infiltration Rate for Retention Facilities shall be 12 inches per hour.
- 4) **Depth to Groundwater:** A site specific determination must be included in the Stormwater Calculation Report to ensure that the minimum separation distance from seasonal high groundwater will be achieved for proposed infiltration facilities, see **Section 2.4.1** for allowable methodologies.
- 5) **Retention Facility Volume:** Must be calculated using the required design storms in [Chapter 2](#) and one of the accepted methodologies outlined in **Section 4.2**. Stormwater outflow from the facility is calculated by applying the Design Infiltration Rate obtained per the Infiltration Testing standard. Retention Facility Sizing calculations must be performed using a hydrograph routing methodology.
- 6) **Isolated Retention Facilities:** If infeasible to discharge to an approved storm drain system, Retention Facilities must be designed to fully infiltrate the 25-year storm without discharge. Additionally, a designated auxiliary overflow must be provided at a safe location for storms larger than the 25-year event.

- 7) **Retention Facility Drain Time:** Retention Facilities must be designed to fully infiltrate or drain within six days, or as approved by the reviewing agency.
- 8) **Bottom Grade:** Less than 0.5% in any direction (applies to facility bottom and subgrade where infiltration is designed to occur).

4.3.2 General BMP Design Standards: All Facilities

The following are general design standards that apply to Retention, Treatment, and Detention BMPs and shall be followed when incorporating any of the items below. Additional BMP specific design standards are provided in **Sections 4.4, 4.5 and 4.6** below. BMP specific design standards shall govern in the case of standard overlap or contradiction.

General Geometric and Hydraulic Design Standards:

- 1) **Side Slope:** Maximum Grade for earth slopes within wetted area:
 - a) 3H:1V Areas not mown
 - b) 4H:1V Areas to be mown
- 2) **Maximum Depth:**
 - a) Maximum ponding depth in parking lots is 9 inches.
- 3) **Safety Fencing:** Safety fences shall be installed on all facilities with any of the following conditions:
 - a) Where fences are required by local building codes.
 - b) The designed ponding depth is 4 feet or greater.
 - c) Areas where small children are present, as required by the local building jurisdiction.
 - d) Where water depths either exceed 3 feet for more than 24 hours or are permanently wet and have side slopes steeper than 3H:1V.
 - e) Where slopes are equal to or steeper than 1.5H:1V.
- 4) **Freeboard:** Unless approved otherwise by the local jurisdiction, freeboard of 6 inches must be provided in facilities with a floor area less than 800 square feet, 12 inches of freeboard must be provided in all other cases, or as shown on applicable standard drawings in Appendix F.
- 5) **Overflow:** All stormwater facilities must be designed to address any overflow above the facility's design storm and have a designated overflow structure capable of safely passing the 25-year storm to an approved location. Overflow calculations must be submitted with the stormwater report.
- 6) **Spillways:** Facilities built aboveground using walls or berms to impound water must have spillways constructed of non-erodable material which discharge to an approved location.
- 7) **Stormwater Facility Proximity:** The Retention or Treatment area of a Stormwater Facility must be located per the criteria below:
 - a) Minimum of 10 feet from structural foundations (Impermeable Liners may be installed in-lieu of the 10-foot separation).
 - b) Minimum of 10 feet from underground tanks (Impermeable Liners may be installed in-lieu of the 10-foot separation).
 - c) Retention BMPs located near property lines must be designed and located such that they do not adversely affect adjacent properties.
 - d) As approved by the reviewing agency.
- 8) **Energy Dissipation:** Energy dissipation must be placed at each entry and exit point to a facility, as well as any outfall. Energy dissipation must be constructed of non-erodible material such as

concrete or rock. Rock apron energy dissipation must be sized appropriately and may not be constructed with material with a nominal gradation less than four inches.

- 9) **Orifice:** The minimum orifice size is 1 inch in diameter.
- 10) **Flow Control Obstruction Prevention:** A minimum 12-inch-deep concrete or rock lined sump must be provided below all orifices and weirs.
- 11) **Access:** Access for stormwater facility maintenance and inspection must be provided per the following:
 - a) Public stormwater facilities – unrestricted all-weather access including to all inlets, pipe openings, and flow control structures, or as specified by the reviewing agency.
 - b) Private stormwater facilities - unrestricted access, which must be traversable by maintenance vehicles during dry months.

General Material Standards:

12) Storage Rock

- a) Shall be Granular Drain Backfill 1½ inch to ¾ inch and installed per the applicable standard drawing.
- b) Storage rock shall be separated from growing media and/or facility subgrade, as specified on the standard drawings, or by non-woven geotextile fabric.
- c) Maximum allowable void space = 35% by volume.

13) **Impermeable Liners:** Liners shall be a minimum 30 mil ethylene propylene diene terpolymer (EPDM), High Density Polyethylene (HDPE), approved equal, or bentonite treated subgrade. Facilities may be partially or fully lined. Underdrains must be installed on fully lined facilities.

14) **Non-Woven Geotextiles:** Geotextiles for separating storage material from subgrade or separation rock shall be Oregon Department of Transportation (ODOT) Drainage Geotextiles Type 1, non-woven meeting ODOT Standard Specification Section 02320. Geotextile under the road base in the Vegetated Filter Strip BMP, 4.5.3, shall be Subgrade Geotextile meeting ODOT Standard Specification Section 02320.

15) **Underdrains/Piping:** Underdrains and piping shall be rigid pipe in compliance with approving jurisdictional standards and/or the current version of the Oregon Specialty Plumbing Code. Facilities with perforated underdrains must have a clean out or access point at the upstream end.

16) **Observation Port:** Facilities that utilize underground vaults of any kind must install at least one observation port and/or an access for maintenance and cleaning. Observation ports shall have a maximum spacing of 200 feet, additional observation ports may be required. Observation port piping shall be a minimum six-inch diameter non-perforated pipe. Equip the end above ground with an operable cap.

17) Curb Openings:

- a) Curb opening width and spacing shall be sized appropriately and constructed per Standard Detail 1.01, or as required by the jurisdictional authority.
- b) Curb openings shall have a local gutter depression of two inches.

General Natural Material Standards:

17) **Ground Stabilization:** All ground within the facility must be stabilized with one of the options below.

- a) **Hydroseeding** – Hydroseeding with tackifier.
 - b) **Matting** – ODOT Type E erosion control matting shall be used to hold the soil in place until vegetation becomes established. If seeding, place seed and then install erosion control matting. If planting, install erosion control matting and then install plants through the matting. Matting is not required on slopes 4H:1V or shallower, or on slopes that have been hydroseeded.
 - c) **Mulch** – Is not allowed below the water quality ponding depth or within the flow path of an inlet or outfall. Mulch shall be either shredded wood chips, coarse compost, or gravel. Mulch must be dye, pesticide, and weed free, spread in a minimum 2-inch layer over bare soil or in a ring around plants. Ensure that mulch does not touch plant stems.
- 18) **Growing Media:** Growing media can be either an imported water quality mix or amended native soil and must be provided at the depths shown on the Standard Drawings provided in **Appendix F**.
- a) Imported Water Quality Mixture – Is based on the ODOT “Water Quality Mixture” and shall be comprised of soil meeting the gradation in **Table 4.1**, and compost meeting ODOT specification Section 03020. A Seal of Testing Assurance certification from the US Composting Council must be provided to the approving jurisdiction for compost.

Table 4.1. Soil Gradation Requirements

Sieve Size	Percent Passing (by Weight)
No. 4	100
No 10	95 - 100
No. 40	40 - 60
No. 100	10 - 25
No. 200	5 - 10

- b) Mix the soil and compost so the “Water Quality Mixture”:
 - i) Is comprised of between 20% - 25% compost and between 75% - 80% soil.
 - ii) Has a pH between 5.5 and 8.0.
 - iii) Does not have clumps greater than 3 inches in any direction.
 - c) Amended Native Soil - If amending native soil, add compost so that the top 18 inches is roughly 30% compost. Compost must meet ODOT specification Section 03020.
- 19) **Vegetation:** This vegetation standard shall be implemented per the requirements in each BMP section as applicable. If this vegetation standard is not specified or implemented, all disturbed ground within a stormwater facility must be stabilized per the Ground Stabilization Standards in **Section 4.3.2.17**.
- a) Landscape plans must be submitted per the submittal requirements outlined in [Chapter 6](#).
 - b) Vegetation planting density must be provided per **Table 4.2 or 4.3** below, **Table 4.4** is optional. Additional planting, siting, and plant selection guidance is provided in **Appendix E**.

- c) At the end of the three-year establishment period, 90% of the Treatment area must have vegetation cover.
- d) Temporary irrigation is required for the first three growing seasons which may consist of, but is not limited to, an in-ground system or an imported water source.
- e) Plants must be maintained per the Operation and Maintenance Manual recorded for the facility.

Table 4.2 Plant numbers and spacing requirements for a vegetation mix consisting primarily of herbaceous plants and small shrubs.

Number of Plants	Vegetation Type	Per Square Feet of BMP	Size	Spacing Density (Average on Center)*
66	Herbaceous Plants	100	Plugs or Larger	1.5 Feet
OR				
58	Herbaceous Plants	100	Plugs or Larger	1.5 Feet
4	Small Shrubs	100	1 Gallon	3 Feet to 4 Feet**
OR				
100% Native low-mow or no-mow seed coverage (follow supplier guidelines for density)				

*An average on-center density is provided as general guidance. However, to prevent short circuiting, plants must be randomly placed throughout per Standard Drawings BMP 4.4.1.b, 4.4.1.d, 4.5.2.b.

**Depending on mature spread. Shrubs may be placed farther away than the density indicated but not closer.

Table 4.3 Plant numbers and spacing requirements for a mix of herbaceous plants, small and large shrubs.

Number of Plants	Vegetation Type	Per Square Feet of BMP	Size	Spacing Density (Average on Center)*
58	Herbaceous Plants	100	Plugs or Larger	1.5 Feet
4	Large Shrubs	100	1 Gallon	4 Feet to 8 Feet**
OR				
6	Medium to Small Shrubs	100	1 Gallon	3 Feet to 8 Feet**
35	Small Shrubs	100	1 Gallon	3 Feet to 4 Feet**

*To reduce erosion, plants should be randomly located, not placed in rows. The average on-center density is provided as general guidance.

**Depending on mature spread. Shrubs may be placed farther away than density indicated but not closer.

Table 4.4 Recommended Minimum Tree Density.

Number of Plants	Vegetation Type	Per Square Feet of BMP	Size
1	Evergreen Tree	300	6 Feet Minimum Height
OR			
1	Deciduous Tree	300	1.5 Inches Minimum Diameter*

*Measured at a height 6 inches above the base.

4.4 RETENTION BMPS

Retention BMPs are designed to hold and infiltrate site runoff for treatment and limit the volume of downstream discharge. Retention BMP design must comply with the Retention and Water Quality Requirements in [Chapter 2](#), Retention and General Design Standards in [Chapter 4](#), and the specific requirements in each BMP section.

4.4.1 Ponded Retention BMP (Rain Garden/ Retention Ponds and Stormwater Planters)



Figure 4.1. An established Rain Garden on a commercial lot, view from an inlet (left), and looking into the facility inlet (right).

Rain Gardens and Retention Ponds impound stormwater runoff above-ground in low lying areas allowing the runoff to infiltrate into the existing subgrade/ground beneath the facility (**Figure 4.1**). Stormwater planters may be either in-ground or above-ground (**Figure 4.2**) and have vertical sides created by curbs, walls or containers. Runoff typically enters the facility above ground via sheet flow, curb cuts, pipes, and/or gutter downspouts. The stormwater will infiltrate into the open bottom of the facility then into the existing subgrade.

A single stormwater planter cell may be installed on flat areas (as smooth as practical). On sloping ground, a stormwater planter may incorporate check dams to create a series of cells where overflow may occur in the lowest elevation cell (**Figure 4.2**).



Figure 4.2. A single basin in-ground Stormwater Planter (left), and an in-ground Stormwater Planter with separate cells (right) to allow the water to pond and overflow to each cell down the facility.

Performance Design Approach and Specific Design Standards:

- 1) Ponded Retention BMP design must comply with the Retention and Water Quality Requirements in [Chapter 2](#) and the Retention and General Design Standards in this chapter.
- 2) An Infiltration Rate safety factor of 2 may be applied if the ground within the Pondered Retention area is fully vegetated per the standards in **Section 4.3.2.19** of this chapter. Otherwise, if not fully vegetated, the facility must be stabilized per the Ground Stabilization standards in **Section 4.3.2.17** of this chapter and an Infiltration Rate safety factor of 3 must be applied.
- 3) Facility must be constructed per the applicable Standard Drawings provided in **Appendix F**.

4.4.2 Pervious Surface Retention BMP

Pervious surfaces (also known as permeable pavements and porous pavements) are stormwater management facilities that allow water to move through void spaces within the pavement surface and rock below and infiltrate into underlying soils.



Figure 4.3. Permeable Pavers intercept rainfall and infiltrate it into the ground, the catch basin will only receive runoff from large storm events.

Pavement Surface Types Overview

Pervious Asphalt and Pervious Concrete. Pervious asphalt and pervious concrete are similar to their impervious counterparts but are made with “open-graded aggregate”, which includes few to no fines (*i.e.* small particles). When bound together, interconnected voids between the aggregate allow water to flow through.

Permeable Pavers. Permeable pavers are paver units of stone, concrete or other durable impervious material with gaps between or within the pavers that provide voids for water to reach sub-soils. Pervious commercial pavers, like pervious concrete discussed above, are now available and may not need space between them.

Flexible Paving Systems. Flexible paving systems are prefabricated grids made of plastics or other solid materials finished with clean sand/gravel or turf. Grids with pervious media provide a stable surface and sometimes resemble lawn.

Pervious Gravel. Conventional gravel surfaces (*i.e.* without a permeable sub-base) are not inherently free draining. During conventional gravel pavement installation, soil is compacted to support vehicular loads, and gravel with many small particles, usually a material like “¾-inch minus drain rock”, is installed and compacted in lifts (*i.e.* smaller portions of the total depth). This results in a low void ratio with little storage for stormwater.

Pervious gravel driveways and walkways are alternatives that can be especially helpful in retrofit situations where drainage problems exist. To create a pervious gravel pavement, specify Granular Drain

Rock ¾-inch to ½-inch, which is the same material used as base rock in other pervious surfaces and has no fine particles.

Site Suitability & Other Considerations:

Pervious surfaces should be placed on compacted soil per the manufacturer or design engineer's recommendation, and should not be located at sites with high incidence of fine aggregate materials, soils, or other materials that would readily clog the pervious surface. Sites that may be poor locations for pervious surfaces include home improvement stores, aggregate or soil supply businesses, and concrete contractor yards.

This manual covers the design of stormwater management facilities only. It is suggested that the pervious pavement structural section be designed by a professional engineer or manufacturer's representative to accommodate the anticipated loading (vehicle or otherwise) assuming a saturated sub-base. This is especially important if any heavier vehicles are expected such as delivery trucks, buses, or garbage trucks.

Performance Design Approach and Specific Design Standards:

- 1) Jurisdiction of the subject right-of-way must approve all pervious surfaces within the right-of-way.
- 2) Pervious Surface Retention BMP design must comply with the Retention and Water Quality Requirements in [Chapter 2](#) and the Retention and General Design Standards in this chapter.
- 3) Facility must be constructed per the applicable Standard Drawings provided in **Appendix F**.
- 4) Finish grade must be < 8.0%.
- 5) Pervious surfaces must be hydraulically isolated, meaning the surface only receives direct rainfall and does not receive run-on from any other areas. If the Pervious Surface receives run-on from other areas, it must be designed per the Underground Retention BMP standards.
- 6) Signage - Signs must be installed identifying the surface as pervious and indicating that stockpiling and sealing are not allowed on the surface.

4.4.3 Underground Retention BMP

Underground Retention occurs when stormwater is stored below the ground surface until it infiltrates into the subgrade/soil below. Stormwater can be stored within the voids of rock and/or within open bottom chambers. These facilities can be located below landscaping or paved areas.



Figure 4.4. Underground chambers (let) are one example of underground Retention when designed to fully infiltrate the Retention storm. Underground Retention can also be designed under a landscape area (right).

Performance Design Approach and Specific Design Standards:

- 1) Underground Retention BMP design must comply with the Retention and Water Quality Requirements in [Chapter 2](#) and the Retention and General Design Standards in this chapter.
- 2) Facility must be constructed per the applicable Standard Drawings provided in **Appendix F** or per the manufacturer’s standard drawings for approved proprietary facilities.
- 3) Pretreatment – To prevent clogging from sediment, pretreatment must be included. Options for pretreatment include inlet sumps, filtration through soil with geotextile separation, a proprietary system with filter media, or if runoff will only be from roofs, gutters or screens may be used.
- 4) UIC guidance – It is likely that underground retention BMPs are considered Underground Injection Control facilities and may need to be authorized by DEQ. Visit DEQ’s UIC webpage or refer to the DEQ Fact Sheet titled “Identifying an Underground Injection Control” for more information.

4.5 TREATMENT BMPS

4.5.1 Soil Filtration BMP (Rain Gardens and Stormwater Planters with Underdrains)

Soil Filtration BMPs collect stormwater and route it through facility substrate, which is typically imported soil and drain rock. The filtration capacity of this BMP is determined by the hydraulic loading of the facility and the infiltration rate of the imported soil. Runoff is captured by subsurface underdrains and routed to an approved discharge location.



Figure 4.5. Stormwater Planters located flush with a public building (left), a fully-lined residential above-ground Stormwater Planter with an underdrain (upper right), and a newly constructed above-ground Stormwater Planter with an underdrain (lower right).

Performance Design Approach and Specific Design Standards:

- 1) Soil Filtration BMP design must comply with the Treatment and Water Quality Requirements in [Chapter 2](#) and the General Design Standards in this chapter.
- 2) Facility must be constructed per the applicable Standard Drawings provided in **Appendix F**.
- 3) Soil Filtration BMP sizing calculations must be performed using hydrograph routing methodology. The facility size is determined by routing the Treatment inflow of the facility versus the infiltration rate (outflow) of the imported soil.
 - The hydraulic loading of the facility is determined per the Hydrologic Design Criteria in this chapter.
 - Soil Filtration BMP shall be sized with a maximum Design Infiltration rate of 12 inches per hour. If using the imported water quality soil mixture, it can be assumed to have an infiltration rate of 12 inches per hour.
- 4) Underdrains must be sized to accommodate the maximum design flow rate for the facility, *i.e.* peak water quality flow rate or peak detention flow rate as applicable.
- 5) Bottom Slopes must be 0 to 1% slope, SWFs with steeper slopes must use check dams to distribute the water.

4.5.2 Water Quality Swale BMP

Water quality swales treat stormwater by conveying it through the substrate and vegetation. Treatment is achieved by filtration and settlement as the water slowly flows through the facility. Swales must be planted with dense vegetation in the Treatment zone to filter the stormwater.



Figure 4.6. A Water Quality Swale with dense mature vegetation that provides filtering of stormwater runoff.

Performance Design Approach and Specific Design Standards:

- 1) Water Quality Swale BMP design must comply with the Treatment and Water Quality Requirements in [Chapter 2](#) and the General Design Standards in this chapter.
- 2) Facility must be constructed per the applicable Standard Drawings provided in **Appendix F**.
- 3) Vegetation - All ground within the treatment area of the Water Quality Swale BMP must be vegetated per the Vegetation standards in **Section 4.3.2.19** of this Chapter.
- 4) Swale Length - Water Quality Swale length shall be calculated based on a minimum residence time of 9 minutes. If runoff enters the swale at multiple locations along its length such that residence time is less than 9 minutes, check dams must be installed per the requirements of this section.
- 5) Roughness Coefficient - Manning's n value must be a value between 0.22 and 0.24.
- 6) Flow Depth - Maximum depth of the water quality flow is 4 inches.
- 7) Bottom Width
 - a) Bottom width = 1 foot minimum and 10 foot maximum
 - b) If the bottom width is wider than 4 feet, flow spreaders or check dams are required every 50 feet.

- 8) Longitudinal Slope
 - a) Minimum slope = 0.5%
 - b) Check dams must be installed on longitudinal slopes greater than 6%.
- 9) Check Dams - Must be constructed of non-biodegradable material such as concrete or rock. Check dams must have a flat top and be installed per the standard drawings in **Appendix F**.
- 10) Flow Spreaders – Must be constructed of non-biodegradable materials per the Standard Detail in **Appendix F**.

4.5.3 Dispersion BMP (Vegetated Filter Strips & Disconnected Downspouts)

Dispersion is a BMP that spreads runoff over a landscape area specifically to reduce pollution and runoff velocity. Dispersion is suitable for various applications that generate relatively small amounts of runoff and/or for runoff that enters the facility in the form of sheet flow.

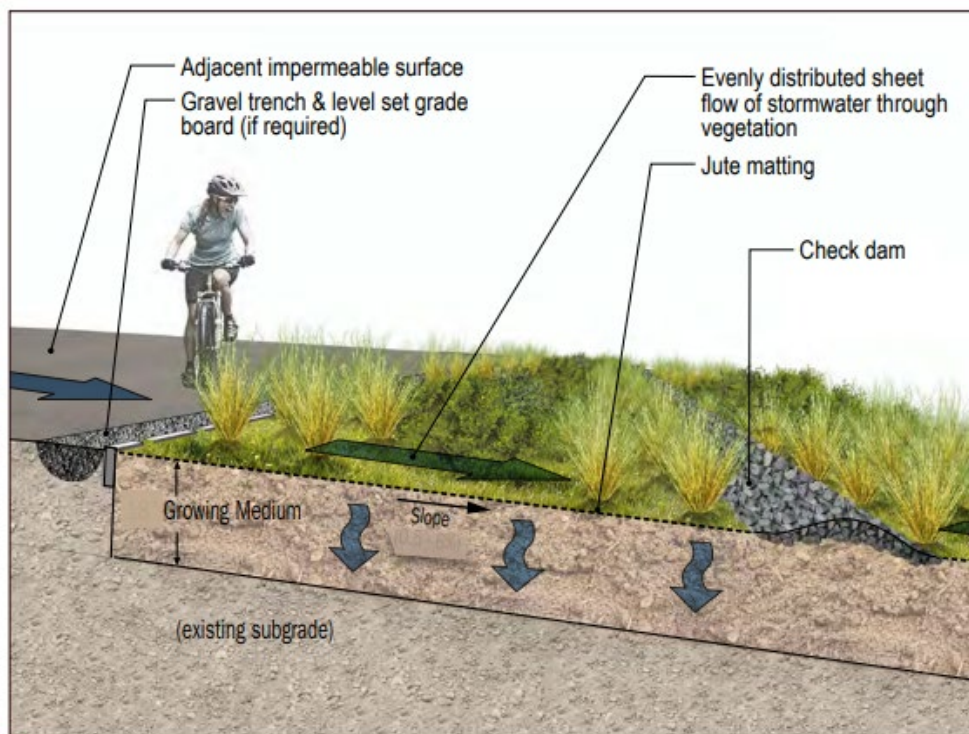

Figure 4.7. Schematic of a Vegetated Filter Strip courtesy of Clean Water Services [LIDA Handbook](#).

Vegetated Filter Strips can be installed along linear features such as roadways, walkways, and patios. Vegetated filter strips typically run parallel to an impervious surface, are gently sloped away from the impervious surface, and must be completely vegetated to filter and reduce velocity as runoff flows through the facility.

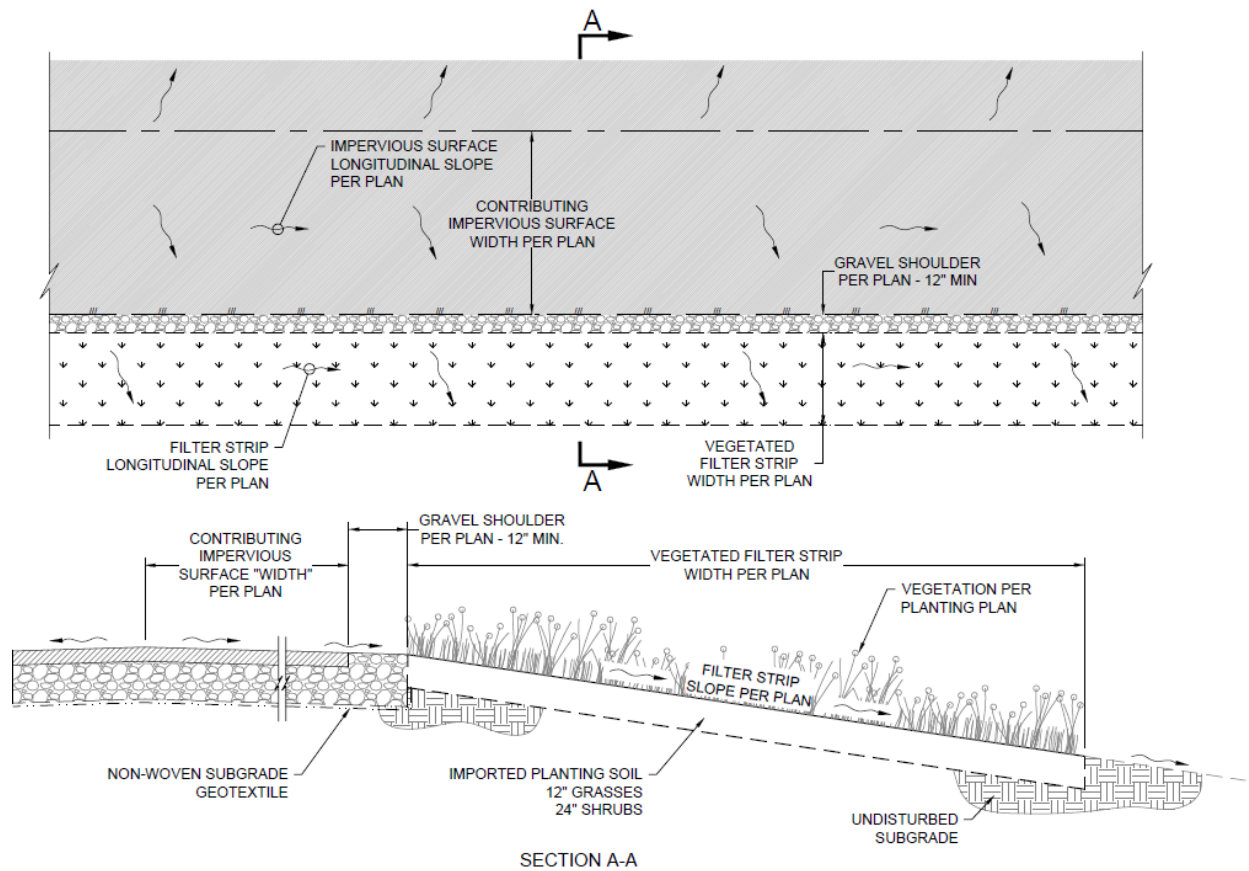

Figure 4.8. Vegetated filter strip general layout along a roadway.

Performance Design Approach and Specific Design Standards:

- 1) The Vegetated Filter Strip BMP design must comply with the Treatment and Water Quality Requirements in [Chapter 2](#) and the General Design Standards in this chapter.
- 2) Facility must be constructed per the applicable Standard Drawings provided in **Appendix F**.
- 3) Vegetation - All ground within the treatment area of the Vegetated Filter Strip must be vegetated per the vegetation standards in **Section 4.3.2.19** of this Chapter.
- 4) Maximum contributing impervious surface “width” prior to entering the facility is 75 feet as measured along the sheet flow drainage path or x-slope of the impervious surface draining toward the Vegetated Filter Strip.
- 5) Maximum slope of impervious surface up-stream of the facility is 5%.
- 6) Maximum longitudinal slope of impervious surface is 4%.
- 7) Maximum longitudinal slope of Vegetated Filter Strip is 2%.
- 8) The width of the Vegetated Filter Strip is sized based on the design slope of the Vegetated Filter Strip and the width of the impervious surface draining to the Vegetated Filter Strip, which is measured along the x-slope or flow path. **Table 4.5** shows treatment capacity of 1 foot of Vegetated Filter Strip at specific design slopes.
- 9) Signage – Signs must be installed identifying each end of the Vegetated Filter Strip, longitudinally. Alternatively, a decorative or utilitarian fence can be installed around the facility.

10) Gravel Shoulder – Minimum 12-inch gravel shoulder must be provided between the impervious surface and filter strip. Non-woven roadway geotextile fabric must extend under the shoulder from roadways.

Table 4.5. Vegetated Filter Strip Treatment capacity vs. design slope

Allowable Vegetated Filter Strip Slopes (%)	Treatment Capacity of 1 Foot of Vegetated Filter Strip Width, Listed in Contributing Impervious Surface Width (feet)
0.5% - 2%	4 Feet (Impervious Surface Width)
2% - 5%	3 Feet (Impervious Surface Width)
5% - 10%	2 Feet (Impervious Surface Width)
10% - 15%	1.5 Feet (Impervious Surface Width)

Example: A Vegetated Filter Strip with a design slope of 4% is to be installed along a standard crowned roadway. The roadway measures 30 feet from edge of asphalt to crown.

$$\text{Vegetated Filter Strip width} = \frac{\text{impervious surface width (ft)}}{\text{Treatment Capacity } \left(\frac{\text{ft}}{\text{ft}}\right)} = \frac{30\text{ft}}{3\left(\frac{\text{ft}}{\text{ft}}\right)} = 10 \text{ foot wide Vegetated Filter Strip}$$

Disconnected Downspouts direct runoff from downspouts or underground drain pipe to a landscaped or mulched area for infiltration and/or filtration in-lieu of discharging directly to a municipal storm drain



Figure 4.9. Disconnected Downspout (Picture Courtesy [Rain Check Buffalo](#))

system. The Disconnected Downspout BMP is only allowed for projects that Develop or Redevelop less than 10,000 square feet of impervious surface. See the Simplified Approach in [Chapter 3](#) for implementation standards.

4.5.4 Water Quality Settling Basin BMP (formerly Extended Detention)

The Water Quality Settling Basin BMP releases stored runoff at a controlled rate over a specified period of time and achieves longer Detention times than with standard Peak Flow Control Detention. This is accomplished by designing the Water Quality Settling Basin to achieve a minimum Detention Time rather than controlling the maximum Peak Flow Rate. Temporary ponding enables particulate pollutants to settle out and reduces the maximum peak discharge to the downstream channel.



Figure 4.10. Example of a Water Quality Settling Basin with a vegetated baffle system to lengthen the distance from the inlet and outlet.

Performance Design Approach and Specific Design Standards:

- 1) Water Quality Settling Basin design must comply with the Treatment and Water Quality Requirements in [Chapter 2](#) and the General Design Standards in this chapter.
- 2) Facility sizing calculations must be performed using hydrograph routing methodology.
- 3) Facility must be designed with a minimum Detention Time of 24 hours. Detention Time is defined as the time to empty the pond from the maximum ponded water surface. The pond shall be considered empty when the calculated water depth is 0.5 inch.
- 4) If the Contributing Drainage Area requires a smaller orifice than 1 inch to attain a Detention Time of 24 hours, this BMP may not be used.
- 5) The minimum length-to-width ratio of the facility is 3L:1W at the maximum water surface elevation. If this ratio cannot be maintained the basin must be equipped with baffles or islands to increase the flow distance between inlet and outlet.
- 6) The distance from the inlet and outlet of the pond must be maximized to facilitate sedimentation.
- 7) The maximum ponded depth for water quality shall be 4 feet.
- 8) Forebay – Must be provided on aboveground ponds with bottom areas greater than 300 square feet. A pre-treatment (sedimentation) manhole may be used in-lieu of a forebay for ponds with

bottom areas less than 1,000 square feet. Forebays and/or pre-treatment manholes must comply with the following standards as applicable:

- a) Forebays must segregate the first 25% of the pond area directly downstream of the inflow to the pond.
- b) Forebay berms must be constructed of non-erodible material such as concrete, masonry, or rock no smaller than 4 inches.
- c) Rock Forebay berm cross section must be generally trapezoidal with a height of 12 inches, a 2-foot minimum top width, and 2H:1V front and back slopes.
- d) Pre-treatment manhole must have an oil/water separation mechanism, minimum diameter of 48 inches, and minimum sump depth of 24 inches.

4.5.5 Proprietary Treatment BMP

Proprietary treatment devices provide water quality treatment by filtering stormwater, or by some other approved method, and are usually installed below grade.



Figure 4.11. Filterra Units (left) and Filter Cartridge Units (right) are examples of proprietary Treatment devices that meet the requirements of this Design Manual.

Performance Design Approach and Specific Design Standards:

- 1) The Proprietary Treatment BMP design must comply with the Treatment and Water Quality Requirements in [Chapter 2](#) and the General Design Standards in this chapter.
- 2) Justification – If a proprietary system is chosen that does not utilize growing media, a statement of why the proprietary system is chosen in-lieu of a BMP with growing media must be included in the calculation report.

- 3) Facility sizing calculations must be performed using hydrograph routing methodology or other methodology accepted by the reviewing agency.
- 4) UIC Guidance – Some proprietary treatment devices that store water underground may be considered Underground Injection Control facilities and may need to be authorized by DEQ. Visit DEQ’s UIC webpage or refer to the DEQ Fact Sheet titled “Identifying an Underground Injection Control” for more information.
- 5) The proposed treatment device must meet one of the following criteria:
 - a) On the Washington Department of Ecology’s Technology Assessment Protocol – Ecology (TAPE) Approved Stormwater Technologies List, <https://ecology.wa.gov/Regulations-Permits/Guidance-technical-assistance/Stormwater-permittee-guidance-resources/Emerging-stormwater-treatment-technologies>. Devices from the TAPE approved list must meet the following criteria:
 - i. Devices must have a General Use Level Designation (GULD) or a Conditional Use Level Designation (CULD).
 - ii. Devices must comply with the Treatment Standards in **Section 2.3** of this manual. Treatment Standards for suspended solids will be considered met for devices designated by TAPE for Basic Treatment.
 - b) On the list of *Pre-Approved Proprietary Stormwater Treatment Technologies*, located in **Appendix G**.
 - c) Proprietary Treatment Systems that are not on the Washington Department of Ecology’s TAPE approved list may be evaluated by the approving jurisdiction for one time use. Data must be collected and submitted to the jurisdiction in accordance with the Technical Guidance Manual for Evaluating Emerging Stormwater Treatment Technologies (TAPE).

4.5.6 Vegetated Roof BMP

Vegetated roofs manage stormwater by holding direct rainfall in the imported growing medium and drainage layer (if used) to be used by the associated vegetation. While the term “green roof” is a more commonly used term, the term “vegetated roof” is more appropriate for much of Oregon, which has dry summers, where some plants are dry and inactive until the rainy season begins again.



Figure 4-12. Vegetated Roof example on a convenience store.

Evaporation from the growing medium and evapotranspiration from the plants releases a high volume of the moisture back into the atmosphere, even in winter, which is unique amongst all the BMPs in this guidance. Vegetated roofs usually consist of a waterproof membrane, an optional drainage layer, an engineered growing medium or soil, a layer of plants and optional mineral mulch for non-irrigated systems.

Performance Design Approach and Specific Design Standards:

- 1) Facility must be designed to meet the water quality requirements in **Section 2.4**
- 2) Performance Design Approach must be performed by an Oregon registered PE or CEG.
- 3) The roof must be vegetated per the Vegetation standards in **Section 4.3.2**.

Vegetated Roof BMP Specific Design Considerations:

Depending on the scale and complexity of the project, the design of vegetated roofs may involve a number of licensed professionals, including a structural engineer, landscape architect, architect, and/or a “Green Roof Professional” (Green Roofs for Healthy Cities, GRP Accreditation). Refer to local building codes and jurisdiction for requirements. The final design will be determined by the licensed professional in responsible charge of the project.

4.6 DETENTION BMP (FLOW CONTROL)

Detention facilities are intended to prevent an increase in peak flow runoff and preserve capacity of downstream storm drains and drainage ways. Detention facilities store runoff that is then slowly released through a designed flow control mechanism such as an orifice, weir, or pump.

Many Retention and Treatment BMPs can provide Detention by incorporating a flow control structure that is typically installed to drain water above the required Retention volume. Detention may also be provided in a facility designed exclusively for storage, such as underground piping, storage rock, vaults or parking lots.



Figure 4.13. A Detention Basin designed to capture and temporarily hold Peak Runoff that is then slowly released through the control structure.

Performance Design Approach and Specific Design Standards:

- 1) The Detention BMP design must comply with the Peak Flow Control: Detention Standards in [Chapter 2](#) and the General Design Standards in this chapter.
- 2) Sizing - Facility sizing calculations must be performed using hydrograph routing methodology.
- 3) Forebay – Must be provided on aboveground ponds with bottom areas greater than 300 square feet. A pre-treatment (sedimentation) manhole may be used in-lieu of a forebay for ponds with bottom areas less than 1,000 square feet. Forebays and/or pre-treatment manholes must comply with the following standards as applicable:
 - a) Forebays must segregate the first 25% of the pond area directly downstream of the inflow to the pond.

- b) Forebay berms must be constructed of non-erodible material such as concrete, masonry, or rock no smaller than 4 inches.
 - c) Rock Forebay berm cross section must be generally trapezoidal with a height of 12 inches, a 2-foot minimum top width, and 2H:1V front and back slopes.
 - d) Pre-treatment manhole must have an oil/water separation mechanism, minimum diameter of 48 inches, and minimum sump depth of 24 inches.
- 4) UIC guidance – If Detention is being provided in an underground facility, it may be considered an Underground Injection Control facility and may need to be authorized by DEQ. Visit DEQ’s UIC webpage or refer to the DEQ Fact Sheet titled “Identifying an Underground Injection Control” for more information.

Chapter 5 - Stormwater Facility Maintenance and Operation Requirements

The Stormwater Facilities Operation and Maintenance Manual (O&M Manual) provides the actions needed to keep the stormwater facility (SWF) operating as designed. The O&M Manual is to be submitted as a separate document from the Stormwater Calculation Report for review and approval. The Declaration of Covenants, contained within the O&M Manual, describes legal responsibilities of the property owner. The entire O&M Manual is to be recorded on the deed of the property and a scan of the final recorded document sent to the approving agency. Agency approval of a project will not be issued until the final O&M Manual is received.

An annual inspection of all SWFs is required, some aspects of the SWF must be inspected during a storm event, refer to the Maintenance Checklists. The property owner must keep a copy of the approved O&M Manual on the property and is responsible for ensuring that maintenance is performed, and records kept, even if maintenance is delegated to a third party.

5.1 OPERATION AND MAINTENANCE ENFORCEMENT

Long term operation and maintenance of structural stormwater controls is required. Oversight inspections by the local approving jurisdiction will be carried out periodically to ensure SWFs are being maintained to function as designed. Failure to properly operate and maintain a SWF may result in financial penalty through the approving jurisdiction's ordinance.

5.2 REVISIONS TO APPROVED STORMWATER FACILITY

Altering an approved SWF may require revised stormwater calculations or civil plans. If a property owner plans to change the design of an approved stormwater facility, they must contact the approving jurisdiction to determine what document revisions will be required. Revisions that must be reviewed include changes to the: inlet structure, discharge structure, facility size, facility slopes, vegetation location or vegetation quantity.

5.3 REMOVAL OF STORMWATER FACILITY DUE TO REDEVELOPMENT

Prior to removing an approved SWF due to redevelopment, a new stormwater management plan and a new O&M Manual must be submitted for review and approval.

5.4 POLLUTION PREVENTION/SPILL RESPONSE

Best Management Practices must be implemented on all sites to prevent stormwater contamination. Spills should be cleaned up following best management practices and should never be washed into a SWF. If a spill occurs into the SWF, contact the approving jurisdiction immediately. Document date and time, weather conditions, what spilled, approximately how much, and any corrective action taken.

5.5 OPERATION AND MAINTENANCE MANUAL CONTENTS

The O&M Manual details who is responsible for maintenance, provides SWF access and design details, describes required and suggested maintenance activities, includes a log-sheet for recording

maintenance actions, and a hazardous spill response fact sheet. A fillable pdf template for the O&M Manual is provided for download and must be used.

Contact Information Form: The entire form must be completed. If contact information ever changes, an updated form must be provided to the reviewing jurisdiction. If a third party will be responsible for operation and maintenance, the Responsible Party Designation form must be completed.

Declaration of Covenants (DoC): The DoC details the legal responsibilities of the property owner. This must include a legal description or the Instrument number for the tax lot(s). The Instrument Number for a tax lot can be obtained from Jackson County's [property database](#). Enter the address or tax lot in the search criteria, then click on "Assessment and Planning Details", click on "Account Detail", scroll down to "Sales Data" to view the Instrument Number. Each jurisdiction adopting this manual will have its own DoC, which must be obtained from them. A DoC is not required for SWFs that will be publicly maintained.

Stormwater Facility Plans: The approved plans for the SWF, including the plan view and details, must be included in the O&M Manual. Only plan sheets pertaining to the SWF design and construction should be included. Plan sheets can be no larger than 8.5 by 14 inches for recording.

Inspection and Maintenance Action Checklists: Standard maintenance checklists are provided for download and are included below for reference. The checklists provide a list of conditions to look for and state whether maintenance is required or suggested should the condition exist. Select only the applicable checklists for the site's stormwater facility and include them in the O&M Manual. If a proprietary structure is used, the manufacturer's maintenance documents must be included. The date of inspection as well as whether maintenance is needed should be documented on the checklist.

Maintenance Record: A generic maintenance record is provided; however, a site specific one can be created as long as it documents inspection dates, items inspected, and dates of any repair work and a description of work completed. Except for trash removal, all actions specified as required on the checklists must be documented. Invoices and work orders for actions taken should be kept as documentation. Records shall be kept for five years and made available to the approving jurisdiction upon request. Whether the facility is operated and maintained by the property owner, or a third party, it is ultimately the property owner's responsibility to ensure that maintenance occurs as required and that records are kept detailing maintenance actions.

Spill Response Guidance: Spills should not be allowed to enter public or private stormwater facilities. A DEQ Fact Sheet for responding to spills is included in the O&M Manual.

STORMWATER MAINTENANCE CHECKLISTS AND RECORD

Inspection and Maintenance Action Checklists

Stormwater Facility Maintenance Record

STORMWATER FACILITY INSPECTION AND MAINTENANCE ACTION CHECKLISTS

Stormwater Facility Design Functions: (Boxes to be checked by designer only.)

The Stormwater Facilities at this site are designed to perform specific functions indicated below, and must be maintained to perform those functions in perpetuity. Changes to the Facility that would alter its designed function require consent from the local approving jurisdiction. Check all that apply:

- Infiltration (All Retention BMP's): Runoff is captured and held only leaving the facility through infiltration into the ground, evaporation or absorption by vegetation.
 - Does the infiltration facility design require 90% vegetation coverage? yes no
 - If Yes, the Inspection and Maintenance Checklist for Vegetated Facilities must be included.
 - If No, the Inspection and Maintenance Checklist for Vegetated Facilities is not required.
- Flow-through Treatment (Water Quality Swale BMP and Dispersion BMPs): Runoff is captured in the facility and flows through vegetation and/or soils before flowing downstream.
 - Does the facility incorporate a Water Quality Swale or Vegetated Filter Strip? yes no
 - If Yes, the Inspection and Maintenance Checklist for Vegetated Facilities must be included.
 - If No, the Inspection and Maintenance Checklist for Vegetated Facilities is not required.
- Filtration Treatment (Soil Filtration BMP and Vegetated Roof): Runoff is captured in the facility and is filtered through a soil substrate before being captured in and discharged through an underdrain.
- Settlement for Treatment (Water Quality Settling Basin BMP): Runoff is captured and held for a specified amount of time to allow solids to settle before being slowly released downstream.
- Proprietary Treatment BMP: Runoff is captured in a proprietary treatment device and is treated as specified by the manufacturer. The manufacturer's maintenance documents must be included.
- Peak Flow Control (Detention BMP): Peak flow from a 10 year event is captured, held, and released at a rate no greater than the pre-developed peak flow rate.

Inspection and Maintenance:

The checklists indicate recommended conditions to look for and actions to take should those conditions exist. They can assist with planning, scheduling, staffing, and budgeting for operation and maintenance of the stormwater facility.

Inspections: At least one inspection per year is required, some items require inspection during a storm event, refer to the Inspection Checklist. Document the date of inspection on the Inspection Checklist and list any maintenance that is needed.

Maintenance Records: Maintenance records must be kept on all stormwater facilities. Trash removal is required to be done, but not required to be documented. All other items listed as required maintenance items must be documented. An example Maintenance Record is provided in this packet. On the Maintenance Record, list the issue to be addressed and the date action was taken and describe the action taken. The individual who inspects and approves the completed work should initial the 'Work approved by' box. Invoices and work orders for supplies and hiring contractors to complete work should be kept on file. The property owner/owners shall keep records of facility system inspections and maintenance for five years from the date of each inspection. Records shall be made available to jurisdictional authority upon request, at no cost.

Manufactured Treatment Structures: These structures will have maintenance requirements from the manufacturer that are included in this packet.

Pesticides: Pesticides (which includes herbicides, insecticides, fungicides), are prohibited within stormwater facilities due to the potential to contaminate downstream waters. Utilize integrated pest management to assess and address pest issues.

Fertilizers: Avoid the use of fertilizers in stormwater facilities. Instead, mulch plants with shredded wood chips or coarse compost. Mulch must be dye, pesticide and weed free.

Pollution Prevention: Best Management Practices must be implemented on all sites to prevent stormwater contamination. Spills should be cleaned up following best management practices and should never be washed into a stormwater treatment facility. If a spill occurs into the stormwater facility, contact the approving jurisdiction immediately. Document time and date, weather conditions, what spilled, approximately how much, and any corrective action taken. If possible, block the inlet to the stormwater facility to prevent the material from flowing in. If the material reaches the stormwater facility, soils and vegetation may have to be replaced.

Inspection and Maintenance Action Checklist			Pervious Pavement	
PROHIBITIONS				
<ul style="list-style-type: none"> No stockpiles of soil/mulch/debris may be staged on the pervious surface and grass/leaves/debris should not be blown onto the surface. Ensure landscape contractors understand that the surface is permeable. Inform them that they cannot stage or blow material onto the surface. Do not seal coat the pervious surface or overlay with an impervious surface. Repair raveling or settling per manufacturer specification. 50sf or less of damage may be patched with conventional asphalt, up to 10% of the entire pervious surface. Snow removal with salt is prohibited. Use salt-free deicers only. Do not apply deicers to concrete <1 year old. Always plow with the blade one inch above the surface. 				
Required Actions				
Surface cleaning		<ul style="list-style-type: none"> Vacuum or dry sweep at least twice a year Or, pressure wash at a right angle to the pavement 		
Conditions to Check for	Action	Required/Suggested	Inspection Date	Maintenance Needed (if none, state none needed)
Erosion from landscape areas onto pervious paving	Implement temporary erosion prevention and sediment control and a permanent fix for the erosion issue(s).	Required		
Reduced infiltration	Must inspect during a storm event. If storms are not infiltrating, contact the jurisdiction.	Required		
Weed and moss growth over 10% of area or more	Mechanically remove during the dry season. Avoid mossicides and herbicides.	Required		
Trash and Leaves	Pick up trash, blow or sweep leaves. Remove and dispose.	Required		
Signage describing Pervious Pavement in place	If a sign was specified on the plans, ensure sign is visible and legible.	Required		
Aggregate loss, potholes, cracks	Repair per manufacturer specification, 50sf or less of damage may be patched with conventional asphalt, up to 10% of the entire pervious surface.	Suggested		
Settling of pavers or loss of paver filling.	Reset pavers and replace missing fill material per original design.	Suggested		

*The Pervious Pavement Checklist applies and must be included for the following BMPs:

- Pervious Surface Retention BMP (pervious asphalt, pervious concrete, pervious pavers)

Inspection and Maintenance Action Checklist		Flexible Paving Systems and Pervious Gravel Surfaces		
PROHIBITIONS				
<ul style="list-style-type: none"> Pesticide use in stormwater facilities is prohibited. No Stockpiles may be located on the flexible paving system or pervious gravel. Ensure landscape contractors understand that the surface is permeable. Inform them that they cannot stage material on the surface or blow grass/leaves/etc. onto the surface. 				
Conditions to Check For	Action	Required/ Suggested	Inspection Date	Maintenance Needed (if none, state none needed)
Erosion from landscape areas onto pervious paving	Implement temporary erosion prevention and sediment control and a permanent fix for the erosion issue(s).	Required		
Reduced infiltration	If storms are not infiltrating, contact the jurisdiction.	Required		
Trash and Leaves	Pick up trash, blow or sweep leaves. Remove and dispose.	Required		
Signage describing Pervious Pavement in place	If a sign was specified on the plans, ensure sign is visible and legible.	Required		
Aggregate loss	Replace with aggregate per original design.	Suggested		
If vegetation is required to function and coverage is poor, Inspect for bare soil, exposed rings, ruts poorly growing grass from too much shade, and thatch.	Reseed, verify irrigation system is functioning. Avoid aeration since this equipment will damage the flexible system.	Suggested		
Maintenance Specific to Pervious Gravel				
Reduced Infiltration	Remove the first few inches of rock and either wash in an area that does not drain to the stormwater system and replace, or replace with new washed rock matching the original aggregate specification.	Suggested		

*The Flexible Paving Systems and Pervious Gravel Surfaces Checklist applies and must be included for facilities that incorporate the following BMPs:

- Pervious Surface Retention BMP (Flexible Paving Systems or Pervious Gravel Surfaces)**

Inspection and Maintenance Action Checklist		Vegetated Facilities*		
PROHIBITIONS				
<ul style="list-style-type: none"> • Pesticide use in stormwater facilities is prohibited. • Removal of vegetation to less than 90% surface cover is prohibited. 				
Conditions to Check For	Actions	Required/ Suggested	Inspection Date	Maintenance Needed (if none, state none needed)
Vegetation covers < 90% of facility surface	<p>Possible Ways to achieve 90% vegetation cover:</p> <ul style="list-style-type: none"> • Determine if irrigation system is functioning properly and fix if needed. • Have a soil fertility test done to determine if nutrient addition is needed, if so add compost. • Add mulch around plantings. • Revegetate following approved landscape plan to achieve at least 90% coverage. 	Required		
Sediment washing out of facility	If sediment accumulated in the facility bottom is washing out, excavate and remove. Assess side slopes and bottom for erosion, fill in any eroded areas with approved soil mix and cover with mulch or vegetation.	Required		
Channelization in Water Quality Swale. Flow has become channelized and does not spread across bottom width of swale.	<ul style="list-style-type: none"> • Recontour to design width and elevation. • Replant vegetation to cover the entire facility bottom. • Consider installing a flow spreader device. Contact the approving jurisdiction for advice on flow spreader installation. 	Required		
Clogged or damaged inlets, outlets, pipes, check dams, perforated pipes or underdrains; if interfering with facility function	<ul style="list-style-type: none"> • Remove sediment and debris to maintain adequate conveyance. • Repair or replace damaged pipes, inlets, outlets to match approved design. 	Required		
Energy dissipator(s) damaged/missing at inlets and outlets (where specified)**	<p>If rock is washing out, evaluate need to replace with larger rock.</p> <p>If missing, replace rock with size and at depth specified.</p>	Required		
Check Dams damaged (if installed)	Maintain design number, spacing and elevation, of check dams.	Required		

Inspection and Maintenance Action Checklist		Vegetated Facilities*		
Ponding for more than six days	In swales, check that outflow is not blocked by vegetation or debris. In infiltration facilities, remove the clogged soil then rake, till or amend the soil with the approved soil mix. Contact the approving jurisdiction to discuss soil replacement if this is insufficient.	Required		
Trash and debris.	Remove and dispose.	Required		
Odor, sludge, or color. Presence of any chemical pollutants.	Notify appropriate jurisdiction to investigate. Remove contaminant by appropriate methods and dispose of as directed by hazardous waste protocols.	Required		
Access to facility is restricted	<ul style="list-style-type: none"> Public facilities must have unrestricted all weather access to all inlets, pipe openings, flow control structures Private facilities must have unrestricted access that is traversable by maintenance vehicles during dry months. 	Required		
Vegetation blocks sight lines, inlets, outlets.	<ul style="list-style-type: none"> Prune vegetation that blocks sight lines, inlets, outlets. Do not string trim grasses, sedges or rushes. Remove dead vegetation before it covers 10% of the surface area. Facilities seeded with low-mow or no-mow seed mix, should be cut a maximum of three to four times a year to reduce fire risk. In infiltration facilities, utilize a weed whacker rather than a mower to reduce compaction of the facility soils. Maintain vegetation at 6 inches or taller in swales. 	Suggested		
Erosion within facility. Check inlets, slopes, energy dissipators and facility bottom.	Any erosion deeper than two inches should be addressed. Determine cause of erosion and eliminate. Refill eroded channels with approved soil media and replant. If possible, redirect flows temporarily and apply appropriate	Suggested		

Inspection and Maintenance Action Checklist		Vegetated Facilities*		
	temporary erosion control best management practices.			

*The Vegetated Facilities Checklist applies and must be included for stormwater facilities that incorporate the following BMPs:

- **Ponded Retention BMP with Vegetation:** eg. rain gardens, stormwater planters and retention ponds designed with 90% vegetation coverage
- **Water Quality Swale BMP**
- **Dispersion BMP:** Vegetated Filter Strips only

****Energy Dissipators:** Typically located below an inlet to a stormwater facility and made of rip-rap, concrete, or a proprietary structure. They prevent scouring of the stormwater facility substrate.

Inspection and Maintenance Action Checklist		Unvegetated Surface Facilities*		
PROHIBITIONS				
<ul style="list-style-type: none"> Pesticide use in stormwater facilities is prohibited. 				
Conditions to Check For	Action	Required/Suggested	Inspection Date	Maintenance Needed (if none, state none needed)
Sediment washing out of facility	If sediment accumulated in the facility bottom is washing out, excavate and remove. Assess side slopes and bottom for erosion, fill in any eroded areas with approved soil mix and cover with mulch or vegetation.	Required		
Clogged or damaged inlets, outlets, pipes, perforated pipes or underdrains; If interfering with facility function	Remove sediment and debris to maintain adequate conveyance. Repair or replace damaged pipes, inlets, and outlets to match approved design.	Required		
Energy dissipator(s) damaged/missing at inlets and outlets (where specified)**	If rock is washing out, evaluate need to replace with larger rock. If missing, replace rock with size and at depth specified.	Required		
Ponding for more than six days	In infiltration facilities, remove the clogged soil then rake, till or amend the soil with the approved soil mix. Contact the approving jurisdiction to discuss soil replacement if this is insufficient.	Required		
Trash and debris.	Remove and dispose.	Required		
Odor, sludge, or color. Presence of any chemical pollutants.	Notify appropriate jurisdiction to investigate. Remove contaminant by appropriate methods and dispose of as directed by hazardous waste protocols.	Required		
Liner (if installed) torn or punctured	Repair or replace as necessary per manufacturer specification.	Required		
Access to facility is restricted	<ul style="list-style-type: none"> Public facilities must have unrestricted all weather access to all inlets, pipe openings, flow control structures Private facilities must have unrestricted access that is traversable by maintenance vehicles during dry months. 	Required		
Erosion within facility. Check inlets, slopes, energy dissipators and facility bottom.	Any erosion deeper than two inches should be addressed. Determine cause of erosion and eliminate. Refill eroded channels with approved soil media. If possible, redirect flows temporarily and apply	Suggested		

Inspection and Maintenance Action Checklist		Unvegetated Surface Facilities*		
	appropriate temporary erosion control best management practices.			

*The Unvegetated Surface Facilities Checklist applies and must be included for facilities that incorporate the following BMPs:

- **Ponded Retention BMP** without Vegetation: eg. rain gardens, stormwater planters and retention ponds designed without 90% vegetation coverage.
- **Soil Filtration BMP**: eg. rain gardens and stormwater planters designed as filtration facilities with underdrains.

****Energy Dissipators**: Typically located below an inlet to a stormwater facility and made of rip-rap, concrete, or a proprietary structure. They prevent scouring of the stormwater facility substrate.

Inspection and Maintenance Action Checklist		Detention & Settling Basins*		
PROHIBITIONS				
<ul style="list-style-type: none"> Pesticide use is prohibited in stormwater facilities. 				
Conditions to Check For	Action	Required/Suggested	Inspection Date	Maintenance Needed (if none, state none needed)
Clogged or damaged inlets, outlets, pipes, perforated pipes, underdrains or check dams; If interfering with facility function	Remove sediment and debris to maintain adequate conveyance. Repair or replace damaged pipes, inlets, and outlets to match approved design.	Required		
Sediment washing out of facility	If sediment accumulated in the facility bottom is washing out, excavate and remove the accumulated sediment. Assess side slopes and bottom for erosion, and stabilize to prevent erosion. If erosion persists, seek technical assistance.	Required		
Energy dissipator(s) damaged/missing at inlets and outlets (where specified)**	Replace rock of size and at depth specified. Evaluate need to replace with larger rock. Repair eroded areas as necessary. Determine cause of rock movement and replace with same size rock or larger as necessary.	Required		
Sediment accumulation exceeding 20 percent of the forebay depth or 4 inches, whichever is less.	Remove sediment.	Required		
Overflow berms or spillways exposed and either actively eroding or vulnerable to erosion.	Replace armoring or replant as directed in design plans and specifications.	Required		
Trash and debris.	Remove and dispose.	Required		
Trash rack or bar screen missing or more than 25% covered	Remove debris and dispose of waste. Repair or replace rack as necessary.	Required		
Odor, sludge, or unusual color. Presence of any chemical pollutants.	Notify appropriate jurisdiction to investigate. Remove contaminant by appropriate methods and dispose of as directed by hazardous waste protocols.	Required		
Access to facility is restricted	<ul style="list-style-type: none"> Public facilities must have unrestricted all weather access to all inlets, pipe openings, flow control structures Private facilities must have unrestricted access that is traversable by maintenance vehicles during dry months. 	Required		

Inspection and Maintenance Action Checklist		Detention & Settling Basins*		
Vegetation blocks sight lines, inlets, outlets.	Prune vegetation that blocks sight lines, inlets, outlets. Do not string trim grasses, sedges or rushes.	Suggested		
Erosion within facility. Check inlets, slopes, energy dissipators and facility bottom.	Determine cause of erosion and eliminate and stabilize to prevent erosion. If possible, redirect flows temporarily and apply appropriate temporary erosion control best management practices.	Suggested		

*The Detention & Settling Basins Checklist applies and must be included for facilities that incorporate the following BMPs:

- Water Quality Settling Basin BMP
- Detention BMP (Flow Control)

****Energy Dissipators:** Typically located below an inlet to a stormwater facility and made of rip-rap, concrete, or a proprietary structure. They prevent scouring of the stormwater facility substrate.

Inspection and Maintenance Action Checklist		Disconnected Downspouts		
PROHIBITIONS				
<ul style="list-style-type: none"> Discharging runoff on another property is not allowed. 				
<ul style="list-style-type: none"> No impervious surfaces may be added within the dispersion area. 				
<ul style="list-style-type: none"> Directly connecting downspouts to the sanitary or stormwater system or directing runoff to flow into the stormwater system is prohibited. 				
Conditions to Check For	Action	Required/ Suggested	Inspection Date	Maintenance Needed (if none, state none needed)
Damaged or missing pipes or downspout extension	Ensure extension ends a minimum of 10 ft from structure. Repair and replace as needed.	Required		
Clogged or blocked pipes, elbows or downspout extension	Clear pipes and elbows of debris to maintain at least adequate capacity. Clear any accumulated debris at downspout extension or splash block. Verify that dispersion area is not encroached upon by other structures.	Required		
Erosion at outlet	Check that splash blocks or energy dissipation is in place and functional. Repair eroded areas as necessary. Repair or replace splash blocks. If rock energy dissipation has moved, determine cause and replace with same size rock or larger as necessary.	Required		
Vegetation blocks downspout extension or visibility.	Prune vegetation that blocks downspout extension or visibility of traffic.	Suggested		

*The Disconnected Downspouts Checklist applies and must be included for facilities that incorporate the following BMPs:

- Dispersion BMP: Disconnected Downspouts

****Energy Dissipation:** Typically located below an inlet to a stormwater facility and made of rip-rap, concrete, or a proprietary structure. Prevents scouring of the stormwater facility substrate.

Inspection and Maintenance Action Checklist		Vegetated Filter Strips*		
Prohibited Actions				
<ul style="list-style-type: none"> • Pesticide use within stormwater facilities. • Removal of vegetation to less than 90% surface cover. 				
Conditions to Check For	Action	Required/Suggested	Inspection Date	Maintenance Needed (if none, state none needed)
Channelization. Flow has become channelized and does not spread over entire facility.	<ul style="list-style-type: none"> • Check condition of flow spreader, repair or replace as needed to evenly disperse flow. • If needed, re-contour facility to design elevation and replant vegetation to evenly cover facility. 	Required		
Vegetation covers < 90% of facility bottom	Possible Ways to achieve 90% vegetation cover: <ul style="list-style-type: none"> • Determine if irrigation system is functioning properly. • Have a soil fertility test done to determine if nutrient addition is needed, if so add compost. • Add mulch around plantings. • Revegetate following approved landscape plan to achieve at least 90% coverage. 	Required		
Trash and debris.	Remove and dispose.	Required		
Access to facility is restricted	<ul style="list-style-type: none"> • Public facilities must have unrestricted all weather access to all inlets, pipe openings, flow control structures • Private facilities must have unrestricted access that is traversable by maintenance vehicles during dry months. 	Required		
Access to facility is restricted	<ul style="list-style-type: none"> • Public facilities must have unrestricted all weather access to all inlets, pipe openings, flow control structures • Private facilities must have unrestricted access that is traversable by maintenance vehicles during dry months. 	Required		
Erosion within facility.	<ul style="list-style-type: none"> • Any erosion deeper than two inches should be addressed. Determine cause of erosion and eliminate. Refill eroded channels with approved soil media and replant. If possible, redirect flows temporarily and apply appropriate temporary erosion control best management practices. 	Required		

Inspection and Maintenance Action Checklist		Vegetated Filter Strips*		
Vegetation blocks sight lines, inflow, outlets.	<ul style="list-style-type: none"> • Prune vegetation that blocks sight lines, inflow, outlets. Do not string trim grasses, sedges or rushes. • Remove dead vegetation before it covers 10% of the surface area. • Facilities seeded with low-mow or no-mow seed mix, should be cut as needed to reduce fire risk. Maintain vegetation at 6 inches or taller. 	Suggested		

*The Vegetated Filter Strips Checklist applies and must be included for facilities that incorporate the following BMPs:

- Dispersion BMP: Vegetated Filter Strips

Inspection and Maintenance Action Checklist		Underground Structures*		
Conditions to Check For	Action	Required/ Suggested	Inspection Date	Maintenance Needed (if none, state none needed)
Sediment and debris exceeding 15% of the structure height or 6" in depth, whichever is less.	Sediment should be removed and disposed of properly at a landfill or approved facility. This may require contracting with a plumbing company that has a vacuum truck. For proprietary structures, follow the manufacturer's maintenance guidelines.	Required		
Plugged or blocked catch basins, pipes, underdrains, silt traps, inlets, perforated pipes, air vents.	Remove sediment and debris to maintain adequate conveyance at all times.	Required		
Cracks in joints between tank or pipe sections that leak soil into the facility.	Manually seal all cracks with appropriate grout material.	Required		
Underground facility structurally deficient or restricting flow.	Repair or replace structure to design.	Required		
Soakage trench surface clogged	<ul style="list-style-type: none"> If water infiltrates through surface, remove and clean rock on the surface. Replace the geotextile fabric on the top, being careful not to damage the fabric on the sides. Place the cleaned rock back over the geotextile fabric. Dispose of sediment in trash destined for the landfill. Sweeping regularly will reduce the likelihood of clogging. High traffic areas will clog faster than low traffic areas. 	Required		
Missing an operable manhole cover.	Replace cover or repair and reinstall.	Required		
Cleanout shear gate damaged, rusted, leaking or missing. Gate cannot be adjusted by one person. Chain or rod missing or damaged	Repair or replace to meet design standards. Repair, lubricate, or replace gate as necessary. Repair or replace chain or rod as necessary.	Required		
Odor, sludge, or unusual color. Presence of any chemical pollutants.	Notify appropriate jurisdiction to investigate. Remove contaminant by appropriate methods and dispose of as directed by hazardous waste protocols.	Required		
Access to facility is restricted	<ul style="list-style-type: none"> Public facilities must have unrestricted all weather access to all inlets, pipe openings, flow control structures 	Required		

Inspection and Maintenance Action Checklist		Underground Structures*		
	<ul style="list-style-type: none"> Private facilities must have unrestricted access that is traversable by maintenance vehicles during dry months. 			

*The Underground Structures Checklist applies and must be included for facilities that incorporate the following BMPs:

- Underground Retention BMP: eg. Soakage trench
- Detention (Flow Control) BMP: eg. Detention pipes, vaults, chambers,

Inspection and Maintenance Action Checklist		Outlet Control Structures/Flow Restrictors*		
PROHIBITIONS				
<ul style="list-style-type: none"> Cannot open valves on stormwater facility structures. 				
Conditions to Check For	Action	Required/Suggested	Inspection Date	Maintenance Needed (if none, state none needed)
Sediment, debris, or trash is blocking or sump is less than 50% from restrictor/orifice plate	Remove and dispose.	Required		
<ul style="list-style-type: none"> Structural integrity. <ul style="list-style-type: none"> Tee-type flow restrictor is not securely attached to manhole wall and outlet pipe. Weir or baffle flow restrictor not securely attached to manhole. Flow restrictor is not plumb within 10% Connections to outlet pipe are leaking and show signs of rust Holes in plates, baffles, elbows, etc. 	<ul style="list-style-type: none"> Determine best method for anchoring flow restrictor based on materials and severity of situation. Replumb and realign restrictor, securing as necessary. Repair or replace as necessary to eliminate leakage. Plug or patch holes if structural integrity is not affected. Replace part if possible, replace entire structure if severely failing. 	Required		
Trash, sediment, or debris blocking overflow pipe.	Remove and dispose.	Required		

*The Outlet Control Structures/Flow Restrictors Checklist applies and must be included for any facility that incorporates the following:

- Outlet Control Structure:** Located at the downstream end of a stormwater facility, it controls the rate at which stormwater can flow out through the use of a flow restrictor.
- Flow Restrictor (Orifice, weir, undersized pipe, etc...):** A designed restriction specifically sized and placed to control stormwater outflow. A flow restrictor can come in the form of a hole (orifice) cut into a plate or pipe, a notch (weir), or an undersized pipe.

Inspection and Maintenance Action Checklist		Culverts/Pipes/Underdrains*		
Conditions to Check For	Action	Required/Suggested	Inspection Date	Maintenance Needed (if none, state none needed)
Trash, debris, or sediment restricting pipe flow.	Remove to maintain adequate conveyance at all times.	Required		
Damage to pipe such as rusting through wall of pipe, dents, bent or crushed ends that affect efficient flow.	Repair or replace pipe as necessary.	Required		
Cracking or buckling of headwall. Erosion or bypassing occurring at backside or around ends of headwall.	Determine extent of problem and monitor for changes. Repair or replace as necessary.	Required		
Missing rock or riprap within upstream or downstream apron areas or side slopes. Active erosion within area.	Repair eroded areas as necessary. Determine cause of rock movement and replace with similar size rock or larger as necessary.	Required		

*The Culverts/Pipes/Underdrains Checklist applies and must be included for any facility that incorporates underdrains, culverts, or pipes specifically for Retention, Treatment, or Detention of stormwater and does not apply to on-site conveyance pipes or catch basins.

Inspection and Maintenance Action Checklist			Vegetated Roofs	
PROHIBITIONS				
<ul style="list-style-type: none"> Pesticide use in stormwater facilities is prohibited. 				
Conditions to Check For	Action	Required/Suggested	Inspection Date	Maintenance Needed (if none, state none needed)
Damaged membrane	Repair or replace.	Required		
Clogged Drains	Remove sediment and debris.	Required		
Vegetation covers < 90% of roof surface	Possible Ways to achieve 90% vegetation cover: <ul style="list-style-type: none"> Determine if irrigation system is functioning properly. Have a soil fertility test done to determine if nutrient addition is needed, if so add compost. Add mulch around plantings. Revegetate following approved landscape plan to achieve at least 90% coverage. Remove and replace per approved landscape plan. Irrigate, if planting in the summer. 	Required		
Erosion	Fill eroded area with approved soil, plant to prevent erosion.	Required		
Standing Water	Check for leaks in irrigation, clear drains, amend soils to restore infiltration.	Required		

STORMWATER FACILITY MAINTENANCE RECORD

Use this record to document inspections. Keep invoices and work orders for maintenance work on file and provide upon request of the approving agency.

Stormwater Facility Type:			
Facility Address:			
Business Name:			
Responsible Party for maintenance:		Position:	
	Phone:	Email:	
Organization:			

Issue	Actions Taken	Date Action Taken	Work approved by:
Issue	Actions Taken	Date Action Taken	Work approved by:

Chapter 6 – Performance Approach Submittal Requirements

6.1 INTRODUCTION

This chapter defines requirements for design calculations, construction plans, landscape plans, and operation and maintenance plans that must be submitted to ensure compliance with stormwater management requirements of this Design Manual. Stormwater management facilities (SWF) designed with the Simplified Approach (refer to **Section 2.7.1**) do not need to be prepared by a licensed engineer and can utilize the submission documents in **Appendix B**. Stormwater facilities designed with the Performance Approach (refer to **Section 2.7.1**) must follow the submission requirements outlined in this chapter.

6.2 PLAN REQUIREMENTS

Stormwater construction plans must be submitted for review in electronic format. Plans must include the following information:

- 1) North arrow and scale;
- 2) Site street address;
- 3) Project location map;
- 4) Grading with existing and proposed topography;
- 5) Existing and new utilities;
- 6) Existing and new storm drain conveyance, including conveyance to and from the SWF;
- 7) Site plan with existing and proposed impervious surfaces;
- 8) Erosion prevention and sediment control plans, as applicable;
- 9) Relevant standard details;
- 10) ROW, easements, property lines and setbacks;
- 11) Any areas of special note i.e., drinking water wells, contaminated soils, steep slopes, waterways, wetlands, riparian buffers;
- 12) Plan view of any SWFs; with all elevations and dimensions necessary to complete calculations in the SWF report and build the SWF;
- 13) If the site will contain multiple SWFs, each SWF must be clearly numbered/named and match the numbering/naming in the Stormwater Calculation Report;
- 14) Profile view of SWF(s) with related elevations and dimensions to complete calculations in the SWF report and build the SWF;
- 15) Detail(s) for the SWF inlet and outlet structure with related elevations and dimensions to complete calculations in the SWF report and build the SWF;
- 16) Proposed stormwater discharge location(s);
- 17) Observation ports and cleanouts, as applicable; and,
- 18) Standard Drawings, General Notes and specifications for the SWF.

6.3 LANDSCAPE SUBMITTAL REQUIREMENTS

Landscape specifications and plans are required for all SWFs requiring vegetation. At this time, there is no required species list for vegetated SWFs; however, species should be drought tolerant and carefully selected for the site conditions, refer to **Appendix E**, Criteria for Choosing Plants, for guidance.

Landscape specifications and plans must address all factors needed to ensure plant survival and must include:

- 1) Delineation of all vegetation to be preserved on-site;
- 2) Statement on whether imported or amended soil will be used and reference to the soil specifications from the required General Notes. The required General Notes must be included in the construction plan set;
- 3) A planting plan that indicates the size, species and location, by hydrologic zone, of all plants within the facility. See **Appendix E, Figure E.1** for guidance on hydrologic zones, as well as the standard drawings for the BMP chosen;
- 4) Plant table that contains scientific and common names, plant size, number and spacing;
- 5) If applicable, seed mix type and volume;
- 6) Irrigation plans for establishment and long term (if different); and,
- 7) Location of any proposed or existing trees to be used for SW credits.

6.4 STORMWATER CALCULATION REPORT

Design calculations per [Chapter 4](#) of this manual must demonstrate that Retention, Treatment, and Peak Flow control is provided for all runoff generated from developed or re-developed impervious surfaces on the subject property. A Stormwater Calculation Report must be submitted that includes the following:

- 1) Cover sheet which includes project name, property owner's name, site street address, map and tax lot, submission/revision date;
- 2) Page numbers on each page of the document (can be hand numbered);
- 3) Engineer of record's contact information, Engineer's stamp (only required for facilities treating 10,000 sf or more of impervious surface and/or providing flow control);
- 4) A short narrative to explain the project, state the type of SWF that is proposed, and how the SWF design meets the requirements of the Rogue Valley Stormwater Quality Design Manual (RVSQDM);
- 5) If the site will contain multiple SWFs, each SWF must be clearly numbered/named and match the numbering/naming on the plans;
- 6) If technical infeasibility for retention is claimed, per **Section 2.4.1**, a technical justification must be provided in the form of a site-specific hydrologic or design analysis conducted or endorsed by an Oregon registered Professional Engineer (PE) or Oregon Certified Engineering Geologist (CEG) demonstrating the presence and extent of infeasibility factors that exist on the site;
- 7) If a proprietary system, not utilizing growing media is chosen, provide a justification for the choice;
- 8) Contributing Drainage map showing on and offsite stormwater flows for each stormwater facility;

- 9) A map showing existing contours or grades a distance of 100 ft from the project area, which can be shown on the drainage map;
- 10) Site conditions including soil types, existing contours and proposed impervious surfaces;
- 11) Infiltration testing report form;
- 12) Values of impervious area acreage to be developed/redeveloped, and final pervious area acreage;
- 13) Total site disturbance area acreage;
- 14) A statement on why the chosen Curve Number is appropriate for the project site;
- 15) Pre- and Post-development Time of Concentration calculations;
- 16) Design assumptions used to size SWF including variables and their sources, design storms, and software used;
- 17) Design calculations, as required for each facility;
- 18) For each facility using the Performance Design Approach provide the following hydrographs and peak flow calculations as applicable (refer to [Chapter 2](#)):
 - a) Retention Storm: Pre-development, post-development and facility routing hydrographs,
 - b) Treatment Storm: Post-development and facility routing hydrographs,
 - c) Peak Flow Control: Pre-development, post-development and facility routing hydrographs,
 - d) Overflow: Post-development and facility routing hydrographs;
- 19) Bypass calculations (only for facilities treating 10,000 sf or more of impervious surface and/or provide flow control); and,
- 20) Statement that access is provided to the SWF for maintenance:
 - a) Public stormwater facilities: Must provide unrestricted all-weather access to all inlets, pipe openings, flow control structures, or as specified by the reviewing agency.
 - b) Private stormwater facilities: Must provide unrestricted access, which must be traversable by maintenance vehicles during dry months.

6.5 PROPRIETARY SYSTEMS

If a proprietary system will be used, in addition to the items in **Section 6.4**, the Stormwater Calculation Report must include the following:

- 1) Documentation from the manufacturer supporting the selected facility type and size.
- 2) Design layout and specifications from the manufacturer for any proprietary SWF.
- 3) All applicable standard drawings from the manufacturer.

6.6 OPERATIONS AND MAINTENANCE PLAN

Operation and maintenance plans are required for all stormwater facilities, refer to [Chapter 5](#), the provided template must be used. A Declaration of Covenants is not required for publicly maintained facilities.

6.7 STORMWATER FACILITY EASEMENT

Stormwater facilities that will be publicly maintained will require the owner to provide a Stormwater Facility Easement. The easement will allow the jurisdiction access to the property for the purpose of constructing, installing, maintaining, and/or inspecting the SWF.

DEFINITION OF TERMS

Best Management Practices (BMPs): Schedules of activities, prohibition of practices, maintenance procedures, and other management practices to prevent or reduce the pollution of waters of the state. BMPs also mean treatment requirements, operating procedures, and practices to control runoff, spillage, or leaks, sludge, or waste disposal, or drainage from raw material storages. See EPA 40 CFR § 122.2 and 122.44(k). For the purposes of this permit, BMPs are synonymous with structural and non-structural stormwater controls and include the schedule of activities, controls, prohibition of practices, maintenance procedures, and other management practices designed to prevent or reduce pollution.

BMPs, Non-Structural: Intangible methods of stormwater management including pollution removal standards, ordinances governing stormwater management, and public education on stormwater quality.

BMPs, Structural: The design and construction of physical structures that provide stormwater management. Structural BMPs are described in **Chapter 3** and **Chapter 4** of this Manual.

Check Dam: A structure constructed perpendicular to the flow path to slow water.

Cleanout: An access point for cleaning out a pipe.

Common Plan of Development: A contiguous construction project or projects where multiple separate and distinct construction activities may be taking place at different times on different schedules, but under one plan.

Construction Activity: Includes, but is not limited to, clearing, grading, excavation, and other site preparation work related to the construction of residential buildings and non-residential buildings, and heavy construction (for example, highways, streets, bridges, tunnels, pipelines, transmission lines, and industrial non-building structures).

Contributing Drainage Area: The total drainage area used to calculate peak flows and runoff volumes and includes all impervious and pervious surfaces that contribute runoff to a specific location.

Control Structure: A device used to hold back or direct a calculated amount of stormwater to or from a stormwater management facility. Typical control structures include vaults or manholes fitted with baffles, weirs, or orifices.

Conveyance: The transport of stormwater from one point to another.

Destination: The ultimate discharge point for the stormwater from a particular site. Destination points can include drywells and sumps, soakage trenches, ditches, drainage ways, rivers and streams, off-site storm pipes, and beneficial uses or re-uses.

Detention: See Peak Flow Control.

Detention Facility: A facility designed to receive, hold, and release stormwater at a rate no greater than the peak flow rate from the pre-developed condition. The volume of water required to achieve the detention requirement can be ponded above ground or stored underground in chambers, vaults, pipes, or available void spaces in rock or soil. The full volume of stormwater that enters the facility is eventually released.

Detention Time: The time to empty the pond from the maximum ponded water surface.

Development: Any human-induced conversion of previously undeveloped or pervious land to impervious surfaces whether public or private, including but not limited to construction, installation, or expansion of a building or other structure, land division, street construction, drilling, and site alteration such as dredging, grading, paving, parking or storage facilities, excavation, filling, or clearing.

Energy Dissipation: Rock, or other material, used to reduce the erosive force of water.

Erosion: A mechanical process of soil movement by water or wind.

Erosion Control Matting: A product made of various materials including straw, coconut fiber, and jute that is attached to the soil to reduce exposure of the soil to wind and precipitation, which cause erosion.

Evapotranspiration: The sum of evaporation and transpiration of water from the earth's surface to the atmosphere. It includes evaporation of liquid or solid water plus the transpiration from plants.

Factor of Safety: A sizing multiplier that evaluates the risks and values of specific conditions, including the failure mode of the construction material, unexpected construction deficiencies, and potential cost of system failure. The safety factor is applied to the maximum performance limit to calculate a risk-based design value used for sizing facilities. A safety factor must be used to provide reasonable assurance of acceptable long-term system performance.

Flow Spreaders: Devices installed perpendicular to the flow direction to evenly distribute flow across a stormwater facility.

Forebay: An area near the inlet of a stormwater facility that is designed to collect sediment and is separated from the rest of the facility by a low wall or flow spreader.

Freeboard: The vertical distance between the maximum ponding depth and the elevation at which overtopping of the structure or facility that contains the water would occur.

Green Infrastructure: A specific type of stormwater control using vegetation, soils, and natural processes to manage stormwater. At the scale of a neighborhood or site, green infrastructure refers to stormwater management systems designed to mimic nature by reducing and/or storing stormwater through infiltration, evaporation and transpiration. At the scale of a city or county, green infrastructure refers to the patchwork of natural areas that provides flood protection and natural processes that remove pollutants from stormwater.

Growing Media: The soil/compost mixture that supports plants and microorganisms within the stormwater facility.

Impervious Surface: Any surface resulting from development activities that prevents the infiltration of water. Common impervious surfaces include: building roofs; traditional concrete or asphalt paving on walkways, driveways, parking lots, gravel lots and roads; and heavily compacted earthen materials.

Infiltration: The percolation of water into the ground.

Infiltration Rate, Design: The infiltration rate measured on site and divided by a Factor of Safety of three.

Infiltration Rate, Measured: The infiltration rate that is measured on site using one of the methods described in **Appendix B**.

Inlet: The point at which stormwater from impervious surfaces or conveyance piping enters a stormwater management facility. The term “inlet” can also be used in reference to a catch basin.

Low Impact Development (LID): A stormwater management approach that seeks to mitigate the impacts of increased runoff and stormwater pollution using a set of planning, design and construction approaches, and stormwater management practices that promote the use of natural systems for infiltration, evapotranspiration, and reuse of rainwater, and can occur at a wide range of landscape scales (i.e., regional, community, and site). Low impact development is a comprehensive land planning and engineering design approach to stormwater management with a goal of mimicking the pre-development hydrologic regime of urban and developing watersheds.

Maintenance Activities: As used in the definition of Redevelopment means activities such as pavement preservation projects, restoration of impervious surfaces disturbed by construction, maintenance or repair utilities, and roof replacement projects.

Maximum Extent Practicable (MEP): The technology-based discharge standard for municipal separate storm sewer systems to reduce pollutants in storm water discharges that was established by Section 402(p)(3)(B)(iii) of the Clean Water Act [33 U.S.C §1342(p)(3)(B)(iii)].

Municipal Separate Storm Sewer System (MS4): Defined in 40 CFR §122.26(b) and means a conveyance or system of conveyances (including roads with drainage systems, municipal streets, catch basins, curbs, gutters, ditches, man-made channels, or storm drains): (i) Owned or operated by a State, city, town, borough, county, parish, district, association, or other public body (created by or pursuant to State law) having jurisdiction over disposal of sewage, industrial wastes, storm water, or other wastes, including special districts under State law such as a sewer district, flood control district or drainage district, or similar entity, or an Indian tribe or an authorized Indian tribal organization, or a designated and approved management agency under Section 208 of the Clean Water Act that discharges to waters of the state; (ii) Designed or used for collecting or conveying storm water; (iii) Which is not a combined sewer; and (iv) Which is not part of a Publicly Owned Treatment Works as defined at 40 CFR §122.2 .

Observation Port: An opening through which the condition of the structure can be observed.

Operations and Maintenance (O&M): The continuing activities required to keep stormwater management facilities and their components functioning in accordance with design objectives.

Orifice: An opening in a control structure through which water flows.

Outfall: The point where a municipal separate storm sewer discharges to waters of the State and does not include open conveyances connecting two municipal separate storm sewers or pipes, tunnels, or other conveyances which connect segments of the same stream or other waters of the state and are used to convey waters of the State.

Overflow: A point through which stormwater that exceeds the facility’s design capacity flows.

Peak Flow Control: The capture, holding, and slow release downstream of runoff from a site during a 10 year event. The practice is intended to protect downstream properties, infrastructure, and natural resources from the increased stormwater runoff peak flow rates and volumes resulting from development.

Performance Approach: Required for the design of BMPs with a Contributing Drainage Area of 10,000 square feet or more. This approach must utilize the calculation and design standards in [Chapter 4](#) and must be performed by an Oregon registered PE or CEG.

Permittee: In the Design Manual, a Permittee is a jurisdiction that has been issued an MS4 permit by DEQ.

Pervious Surface: A natural or created surface that allows water to percolate through it into subsurface drainage systems or the ground.

Pesticide: Any substance or mixture of substances intended for preventing, destroying, repelling, or mitigating any pest. As used in the Federal Insecticide, Fungicide, and Rodenticide Act (FIFRA); a pest is any insect, rodent, nematode, fungus, weed, or any other form of terrestrial or aquatic plant or animal life or virus, bacteria, or other micro-organism.

Pollutant: An elemental or physical product that can be mobilized by water or air and creates a negative impact on the environment. Pollutants include suspended solids (sediment), heavy metals (such as lead, copper, zinc, and cadmium), nutrients (such as nitrogen and phosphorus), bacteria and viruses, organics (such as oil, grease, hydrocarbons, pesticides, and fertilizers), floatable debris, and increased temperature.

Post-Developed Condition: As related to new or redevelopment: A site's ground cover after development.

Predevelopment Hydrologic Function: The hydrology of a site reflecting the local rainfall patterns, soil characteristics, land cover, evapotranspiration, and topography. The term predevelopment as used in predevelopment hydrologic function is consistent with the term predevelopment as discussed in Federal Register Volume 64, Number 235 and refers to the runoff conditions that exist onsite immediately before the planned development activities occur. Predevelopment is not intended to be interpreted as the period before any human-induced land disturbance activity has occurred.

Proprietary Treatment Technology: A manufactured structural facility designed to remove pollutants from stormwater.

Redevelopment: A project that entails Construction Activities, occurs on a previously developed site and results in the addition or replacement of impervious surface. To the extent allowable under federal law, Redevelopment does not include: Maintenance Activities; Construction Activities conducted to ameliorate a public health or safety emergency or natural disaster; and/or Construction Activities within an existing footprint to repair or replace a site or a structure damaged by a public health or safety emergency or natural disaster.

Retention: As defined in this manual, capture of stormwater runoff above the pre-developed volume that is only released via infiltration, evapotranspiration or reuse on-site.

Retention Facility: A facility designed to receive and hold stormwater runoff. Any runoff above the pre-developed volume may only leave the facility via infiltration, evapotranspiration, or absorption by surrounding vegetation. In this way, retention facilities reduce the total volume of excess water released to downstream conveyance facilities.

Roughness Coefficient: The resistance to flow, as represented by the Manning's n value.

Runoff Curve Number: A number used to categorize runoff potential based on soil types and land use. They were defined by the Natural Resources Conservation Service and are published in TR-55, Table 2.2, which is included in **Appendix D**.

Santa Barbara Urban Hydrograph (SBUH): A hydrologic method used to calculate runoff hydrographs.

Sedimentation: The process of depositing soil particles that were suspended in water or air.

Simplified Approach: Intended to be a streamlined stormwater management approach for small projects and is not required to be performed by an Oregon registered PE or CEG.

Storm Event: Any precipitation that falls within a defined time period and geographic area.

Stormwater Management: As used in this manual, is the combination of techniques used to reduce pollutants in stormwater through Retention, Treatment or Detention.

Stormwater Management Facility (SWF): A structural stormwater control designed to provide Retention, Treatment, or Detention, or a combination thereof at one location.

Stormwater Management Program (SWMP): A comprehensive program to manage the quality of stormwater discharged from the MS4. The SWMP consists of the actions and activities conducted by the Permittee as required by the MS4 permit.

Stormwater Runoff: Snow melt runoff, surface runoff and drainage, and is defined in 40 CFR §122.26(b)(13). “Stormwater” means that portion of precipitation that does not naturally percolate into the ground or evaporate, but flows via overland flow, interflow, channels, or pipes into a defined surface water channel or a constructed infiltration facility.

Stormwater System Capacity: The capacity of a stormwater drainage system is the flow volume or rate that a facility (e.g., pipe, pond, vault, swale, ditch, drywell) is designed to safely contain, receive, convey, reduce pollutants from or infiltrate stormwater and that meets a specific performance standard.

Subwatershed: A subdivision of a watershed that is the sixth-level 12-digit unit of the hydrologic unit hierarchy as defined by the National Watershed Boundary Dataset (USGS et al 2013).

Sump: Any volume of a facility below the point of outlet, in which water can accumulate.

Time of Concentration (T of C): The time it takes stormwater runoff to travel from the most distant point on a particular site or drainage basin to a particular point of interest.

Total Suspended Solids (TSS): A measure of solids suspended in the water column that is greater than 0.45µm in diameter.

Transpiration: Release of water vapor into the atmosphere through plant stomata or pores.

Treatment: As defined in this manual, removal of TSS from stormwater runoff.

Treatment Facility: A facility designed to remove TSS.

Treatment Train: A series of stormwater facilities designed to meet or exceed the treatment standards required by this Manual.

Underground Injection Control (UIC): A Federal program under the Safe Drinking Water Act, delegated to the Oregon Department of Environmental Quality (DEQ), which regulates the injection of water below

ground. The intent of the program is to protect groundwater aquifers, primarily those used as a source of drinking water, from contamination. For information on UICs see Oregon DEQ UIC page.

Appendices

- Appendix A Infiltration Testing Methodology
Falling Head Test Report Form
- Appendix B Simplified Approach Procedure and Details
- Appendix C Santa Barbara Urban Hydrograph Spreadsheet Example
SBUH Excel spreadsheet for download
- Appendix D NRCS Table of Curve Numbers and Time of Concentration Calculation
Medford IDF Curves
- Appendix E Plant Specifications
Plant Material Source List
- Appendix F Standard Drawings Index
General Construction Notes and Material Specifications
PDF Standard Drawings
DWG Standard Drawings
- Appendix G SWAT Pre-Approved Proprietary SW Treatment Technologies
- Appendix H Stormwater Operation and Maintenance Plan Templates
O&M Manual Template (fillable pdf)
Section B: RVSS Declaration of Covenants
Medford Declaration of Covenants
Section D: Medford Subdivision O&M Agreement
Section F: SW Facility Inspection and Maintenance Checklists
- Appendix I RVSS Stormwater Credits

Appendix A - Infiltration Testing Methodology

Table of Contents

- Infiltration Testing Methodology A-1
- Applicability A-1
- Infiltration Pit Timing and Layout A-1
- Simple Pit Falling Head Test for Simplified Approach A-4
- Ribbon Test for Soil Texture Identification A-6
- References A-7

INFILTRATION TESTING METHODOLOGY

Perform an infiltration test to determine the soil's capacity to absorb and percolate water down into the lower layers. The infiltration test establishes the measured infiltration rate. The Design infiltration rate shall be determined per the Design Infiltration Rate Standards outlined in Chapter 4.

APPLICABILITY

Performance Design Approach: For projects developing or redeveloping 10,000 square feet or more, infiltration testing must be overseen by an Oregon registered Professional Engineer (PE) or Oregon Certified Engineering Geologist (CEG). One of the following methodologies must be used:

- Open pit falling head
- Encased falling head
- Double-ring infiltrometer

Documentation of the method selected, the reason for selecting the method, a map of testing locations and results must be submitted with the stormwater management report.

Simplified Design Approach: The Simple Pit Falling Head Infiltration Testing method described below may be used for projects developing or redeveloping less than 10,000 square feet. This testing can be performed by anyone, but the results of the test must be submitted on the provided data form.

INFILTRATION PIT TIMING AND LAYOUT

Timing

Tests should not be conducted:

- In the rain
- Within 24 hours of a storm greater than 1/2 inch, or
- When the ground is frozen.

Different protocol, as described below in "Test Infiltration", apply to wet-weather versus dry-weather testing.

Location

The test measures infiltration of a very small and specific area. In new developments and redevelopments with generous open space, infiltration tests should be performed across the proposed development area during the planning phase. Tests must be conducted within the footprint of the proposed facility. Thus, once the location of facilities is determined, additional design phase infiltration testing may be needed if the initial tests were not conducted within the footprint of the proposed facility.

In retrofits with limited areas to choose from, infiltration testing in the planning phase isn't needed. Simply test directly within the proposed facility location.

Number of Tests

- When using the Simplified Design Approach, at least 1 test must be conducted for each proposed SW facility.
- The number of infiltration tests for large sites varies widely. At least 1 test per 10,000 square feet of land to be developed or redeveloped is required. More tests are needed for sites with variable soil conditions than for sites that are uniform. In urban sites, where soils may have been disturbed a number of times over many years, soil conditions may vary greatly over small distances, so more tests may be needed. A geotechnical engineer can assist with identifying soil uniformity and identifying the appropriate number of tests. The approving jurisdiction reserves the right to require additional infiltration testing.

Testing depth

Testing depth varies with existing and final conditions, testing goals, and BMP choices.

Runoff prevention. If fast(er) draining soils will simply be conserved, an infiltration test depth of 6 inches to 12 inches into the soil just below the ground cover vegetation and topsoil, is sufficient depth.

Runoff reduction. Infiltration testing should be performed at the expected depth of the bottom of the facility; however, infiltration testing may also determine the depth of the facility. Evaluate a very simple rain garden that doesn't replace or amend the native soils by testing the soils shallowly. Since the suitability at this shallow depth cannot be known until the test is completed, dig a few test holes at different elevations a few feet apart and test them simultaneously.

Existing and proposed finish grades should be used to determine appropriate testing depths for all applicable BMPs, similar to the examples below.

Example A-1 Simple infiltration rain garden (existing grade elevation similar to final grade)

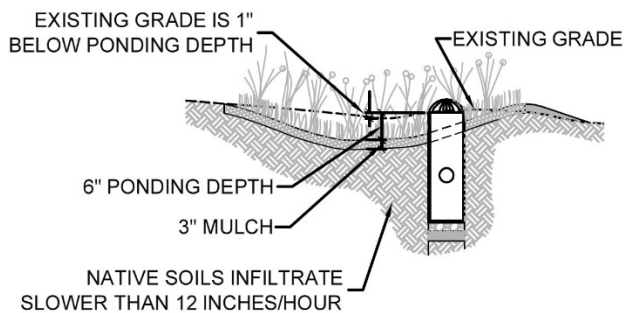

Infiltration testing depth = -1" (elevation difference) + 6" (ponding depth) + 3" (mulch) = 8 inches below existing grade

Example A-2 Infiltration rain garden with imported soil (existing grade elevation higher than final grade)

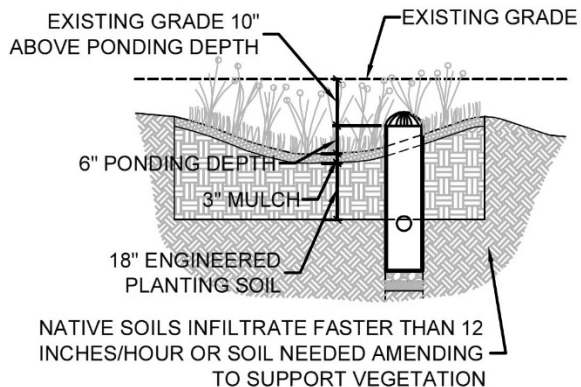

Infiltration testing depth = 10" (elevation difference) + 6" (ponding depth) + 3" (mulch) + 18" imported soil = 37 inches below existing grade

Example A-3 Infiltration rain garden with imported soil (existing grade elevation lower than final grade)

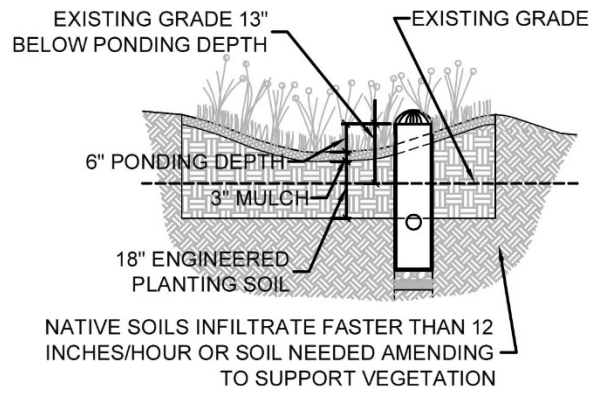

Infiltration testing depth = -13" (elevation difference) + 6" (ponding depth) + 3" (mulch) + 18" imported soil = **14 inches below existing grade**

SIMPLE PIT FALLING HEAD TEST FOR SIMPLIFIED APPROACH

The Simple Pit falling head test is one of the oldest and simplest methods.

Safety

Always call 811 (or visit <http://digsafelyoregon.com/>) to locate utilities before testing begins. Infiltration tests may require extensive excavation and can be potentially dangerous. Observe relevant Occupational Safety and Health Administration (OSHA) regulations. Excavation should never be left unsecured and unmarked, and all applicable authorities should be notified prior to any work.

Equipment Needed

- Shovel and/or post-hole digger
- Yardstick or ruler
- Water source
- Some clean gravel (in clay soils)
- Pencil
- Paper for recording fall over time
- Falling Head Soil Infiltration Testing Report Form
- Watch or timer
- Water jug (optional)



Figure A-1. Anyone fit enough to dig can perform an infiltration test with commonplace tools.

Perform a Simple Pit falling head test as follows:

1. Dig a test hole with a post hole digger or a larger area with a shovel. The area of the hole doesn't matter. Dig a hole to the appropriate depth as discussed above.
2. Perform a ribbon test as described in the Ribbon Test section below.
3. If soils are clayey, roughen the sides of the hole a little (i.e. scarify). Remove the scraped material from the bottom of the hole and place an inch or so of clean gravel at the bottom; otherwise, the tiny clay particles will be suspended in the water and will form an impermeable barrier (appearing as a sheen) around the sides and bottom of the hole.
4. Push a pencil or nail into the side of the hole from which to measure the water level drop over time. The height above the bottom of the hole (or gravel if included) will determine the water level depth. Because water is so heavy, deeper water will result in faster overall infiltration rates, so this is accounted for in the following:

Runoff Prevention. Place the pencil or nail 6 inches above the bottom of the hole.

Runoff Reduction. The depth of water should reflect the amount of water that might be ponded in a runoff reduction BMP. For instance, if the ponding depth will be 9 inches, then place the pencil or nail 9 inches above the bottom of the hole. If the ponding depth is unknown, 6 inches is conservative.

5. Fill the hole with water gently to the top of the pencil or nail. Record the exact time you stop filling the hole (if soils are fast draining, measure time down to the second). Measure and record the water level at regular intervals for a minimum of one hour, or until all the water has infiltrated. Record the distance between the water surface and the pencil at each time interval.
6. If testing during the rainy season and soils are saturated, go on to step 7. If testing during the dry season and soils are dry, refill the hole again and immediately repeat steps 2 to 5 two more times.
7. To calculate the infiltration rate, divide the distance that the water dropped by the amount of time it took for it to drop. For example, if the water dropped 6 inches in 12 hours, then 6 divided by 12 equals 0.5 inches per hour. The completed data sheet must be submitted to the approving jurisdiction with the Stormwater Management Report.
8. If testing is for porous pavement managing direct rainfall only, skip to step 9. For rain gardens and stormwater planters and porous pavements managing runoff, if the slowest infiltration rate measured is less than 0.5 inches per hour, then dig another hole nearby, but 3 to 6 inches deeper, and repeat steps 1 to 5 to see if there's a faster draining soil that could be over excavated to. Repeat this process at various depths down to another 2 feet, or until you have at least 0.5 inches per hour infiltration. If you can't find a suitable area with an infiltration rate of at least 0.5 inches per hour, the Performance Design Approach must be used. Skip to step 10.
9. For porous pavements that infiltrate rainfall, if the slowest infiltration rate measured is less than 0.3 inches per hour, consider relocating the porous pavement to a faster draining soil. If this is not possible and the infiltration rate below the porous pavement managing rainfall only is less than 0.3 inches per hour, then the porous pavement must be designed using the Performance Approach.



Figure A-2. A shovel was used to dig most of the way then a 6" diameter post hole digger was used to reach the proposed bottom elevation of a rain garden. Measure the drop in water from a known, stable marker.

Confirm Vertical Separation

Two conditions for vertical separation should be met:

10. After infiltration testing is complete, dig the hole another 2 feet of depth from the bottom of the BMP (*i.e.* the elevation where water will begin to pond) to uncover bedrock or other impermeable subsurface layers, such as compacted ash, that may impede infiltration. If the soil is pretty consistent all the way down then one criteria for vertical separation is met.
11. If testing during the winter, dig the hole one foot deeper to discover groundwater. If water doesn't seep into the hole, then groundwater is sufficiently deep and the second vertical separation criteria is met. If not testing during the winter, hire a registered soil scientist, licensed geotechnical engineer, registered geologist, or other qualified licensed professional to assist with assessing the depth of the seasonal high groundwater table.
12. Fill the hole back up, and leave the site in a safe condition (*i.e. prevent a tripping hazard*).

RIBBON TEST FOR SOIL TEXTURE IDENTIFICATION

As indicated above, to properly implement an infiltration facility, you need to approximately identify the soil texture of your existing native soils, which may range from more sandy to more clayey.

Determine soil texture:

1. Take a handful of the soil you have excavated from your infiltration test. Pulverize it in your hand and remove any bits of organic matter or obvious rocks.
2. Wet it with a small amount of water and rub it between your thumb and index finger. Don't saturate it until it is runny mud. You might feel stickiness, grittiness, or smoothness. The grittier the feel, the more sand is present in your soil. The slicker the soil, the more clay in it. Smooth soils are sometimes an indicator of a fine silt or loam. Discard the soil.
3. Next, take another sample in your hand. Wet it until it has the consistency of dough. You should be able to form a ball that holds together with the soil in your palm. If you cannot get the ball to form, then your soil is very sandy. In most soils, however, you should be able to create a rough ball.



Figure A-3. Step 3 of the ribbon test.

4. Knead the soil together between your thumb and fingers and attempt to form a ribbon. As you build the ribbon, it will either hold together or break off.



Figure A-4. Step 4 of the ribbon test.

Interpret Your Results. If the soil forms a ribbon:

- Less than 1 inch in length before it breaks, the soil is sandy or silty.
- 1 to 2 inches in length before it breaks, the soil is clayey (i.e. has some clay).
- Greater than 2 inches before it breaks, the soil is clay.

REFERENCES

City of Portland Stormwater Management Manual (2016). Chapter 2: Stormwater Facility and Conveyance Design, Submittal Requirements. Retrieved from:
<https://www.portlandoregon.gov/bes/index.cfm?&c=64040>

Simple Pit Falling Head Test Report Form

Project Name: _____ Project number: _____

Individual conducting test: _____ Email: _____

Phone: _____

1. Follow the protocol provided in Appendix B of the Rogue Valley Stormwater Design Manual for the Falling Head Test.
2. The bottom of the test pit should be located at the proposed final grade for the stormwater facility bottom.
3. Three repetitions are required. Do not average the results. The third test provides the best representation of infiltration rate under saturated conditions.
4. Attach an aerial map or drawing of the site showing the location of the soil test pits.

Pit 1				
Date of Test				Pit Location Description:
Depth of Excavation				
	Test 1	Test 2	Test 3	
Time of Day				
Duration (hours)				
Initial Water Depth (inches)				
Final Water Depth (inches)				
Infiltration Rate (inches/hr)				

Pit 2				
Date of Test				Pit Location Description:
Depth of Excavation				
	Test 1	Test 2	Test 3	
Time of Day				
Duration (hours)				
Initial Water Depth (inches)				
Final Water Depth (inches)				
Infiltration Rate (inches/hr)				

Pit 3				
Date of Test				Pit Location Description:
Depth of Excavation				
	Test 1	Test 2	Test 3	
Time of Day				
Duration (hours)				
Initial Water Depth (inches)				
Final Water Depth (inches)				
Infiltration Rate (inches/hr)				

Attach more sheets if additional soil pits are needed.

Appendix B – Simplified Approach

TABLE OF CONTENTS

Appendix B – Simplified Approach.....	B-1
Simplified Approach.....	B-1
Procedure Outline:.....	B-1
Option Descriptions:	B-2
Rain Garden.	B-2
Stormwater Planter.....	B-2
Pervious surface.....	B-3
Vegetated Filter Strip.....	B-3
Disconnected Downspouts to Pervious Area.....	B-4
Disconnected Downspouts to Infiltration Trench.....	B-4
Submission Forms and Standard Drawings	

Simplified Approach

Installing water quality treatment facilities is a required component of any project that adds or redevelops more than 5,000 square feet of impervious area (asphalt, concrete, roofs, etc). Stormwater pipes generally dump directly into the local creeks and therefore it is important to treat the water for pollutants before it flows off the site.

PROCEDURE OUTLINE:

1. **Impervious Area:** Determine the area (square footage) of the new or redeveloped impervious surfaces associated with the project. Impervious surfaces include roofs, asphalt, concrete, gravel used by vehicles, and other surfaces that prevent rain from soaking in to the ground. This Simplified Approach is only allowed if the project has less than 10,000 square feet of new or redeveloped impervious area.
2. **Treatment Option and Location:** Select one of the treatment options listed below and determine where the facility should be placed so that it can receive and treat all water that runs off the new or redeveloped impervious surface during a rainstorm.
3. **Drainage Area:** Check to make sure that additional water won't drain into the new treatment facility, such as from an existing parking lot or building. If this is the case, work with the local jurisdiction to make sure the treatment facility is sized correctly, or plan on changes to the site so that this water doesn't enter the treatment facility.
4. **Form:** Fill out the form for the treatment facility selected.
5. **Site Plan:** Create the site plan (see requirements on the form).
6. **Operations and Maintenance Plan:** Fill out the Operations and Maintenance Plan for the treatment facility selected.
7. **Submittal:** Submit the Form, Site Plan, Operations and Maintenance plan and Declaration of Covenants to the local jurisdiction for approval.
8. **Declaration of Covenants:** Execute the Declaration of Covenants for continued maintenance of the facility.
9. **Record Documents:** Record the Operations and Maintenance Plan and the Declaration of Covenants on the property.

OPTION DESCRIPTIONS:

Rain Garden.

Rain gardens hold rainwater in low lying areas allowing the water to soak into the ground.



Stormwater Planter.

Stormwater planters may either be in-ground or above-ground and have vertical sides created by curbs, walls, or containers. The planter needs to have an open bottom that allows water to soak into the ground.



Pervious surface.

Pervious surfaces allow water to move through openings within the pavement surface so that the water can soak into the rock and soil below. These surfaces can be porous pavers (stones), pervious concrete, or porous asphalt.



Vegetated Filter Strip.

Vegetated filter strips can be placed alongside impervious surfaces such as roadways, walkways, and patios, where rainwater drains off the pavement, filters through the vegetation and then soaks into the ground. Vegetated filter strips run along the paved surface, are gently sloped away from the surface, and must be completely vegetated.



Disconnected Downspouts to Pervious Area.

Rainfall from the roof flows through downspouts or underground drain pipe to a pervious (not paved) area so that the water can soak into the ground instead of draining to the public storm drain system.



Disconnected Downspouts to Infiltration Trench.

Rainfall from the roof flows through downspouts or underground drain pipe to a trench filled with gravel so that the water can soak into the ground instead of draining to the public storm drain system.

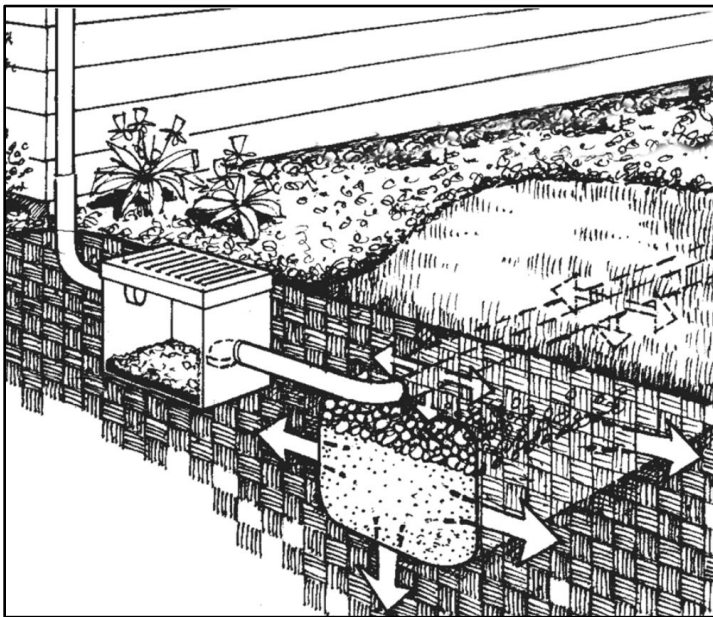

RAIN GARDEN – SIMPLIFIED APPROACH

This form should be used when there are no civil plans for the project.

Project Name: _____ Permit / Project #: _____

Address: _____ Map and Taxlot: _____ Building Permit: _____

Property Owner: _____ Phone: _____

Project Description: _____

RAIN GARDEN SIZE

New or Redeveloped Impervious Area = _____ square feet

Rain Garden Size (0.05 x New or Redeveloped Impervious Area) = _____ square feet

RAIN GARDEN LOCATION

Site Description (**attach a site plan**): _____

Proposed Location of Facility (**indicate on attached site plan**): _____

RAIN GARDEN DRAINAGE

How will stormwater enter the rain garden?

Flow across ground surface (**show slope direction on the attached site plan**)

Pipe (**show pipes and catch basins on attached site plan**)

Spillway: During heavy rainstorms, when the rain garden fills up, where will any excess water go if the rain garden overflows? (**show drainage path on attached site plan**) _____

REQUIREMENTS

Property Owner to provide initials:

_____ Rain garden will be the size calculated above, or larger

_____ Rain garden will be planted with vegetation

_____ During heavy rainstorms, rain garden will not overflow onto a neighboring property

_____ Rain garden will be at least 10 feet away from building foundations

_____ All new or redeveloped impervious area will drain to the rain garden(s)

_____ I have read and understood the following: Even though this approach is allowed without an Oregon registered Professional Engineer (PE) or an Oregon Certified Engineering Geologist (CEG), there may be features of the project that would be best addressed by a PE or CEG to avoid negative results such as poor site drainage, high groundwater, or flooding. The project manager and owner should assess these risks to determine whether a PE or CEG should be hired to develop a site design including a grading, drainage, and or utility plan.

Owner Name: _____ Date: _____

Signature: _____

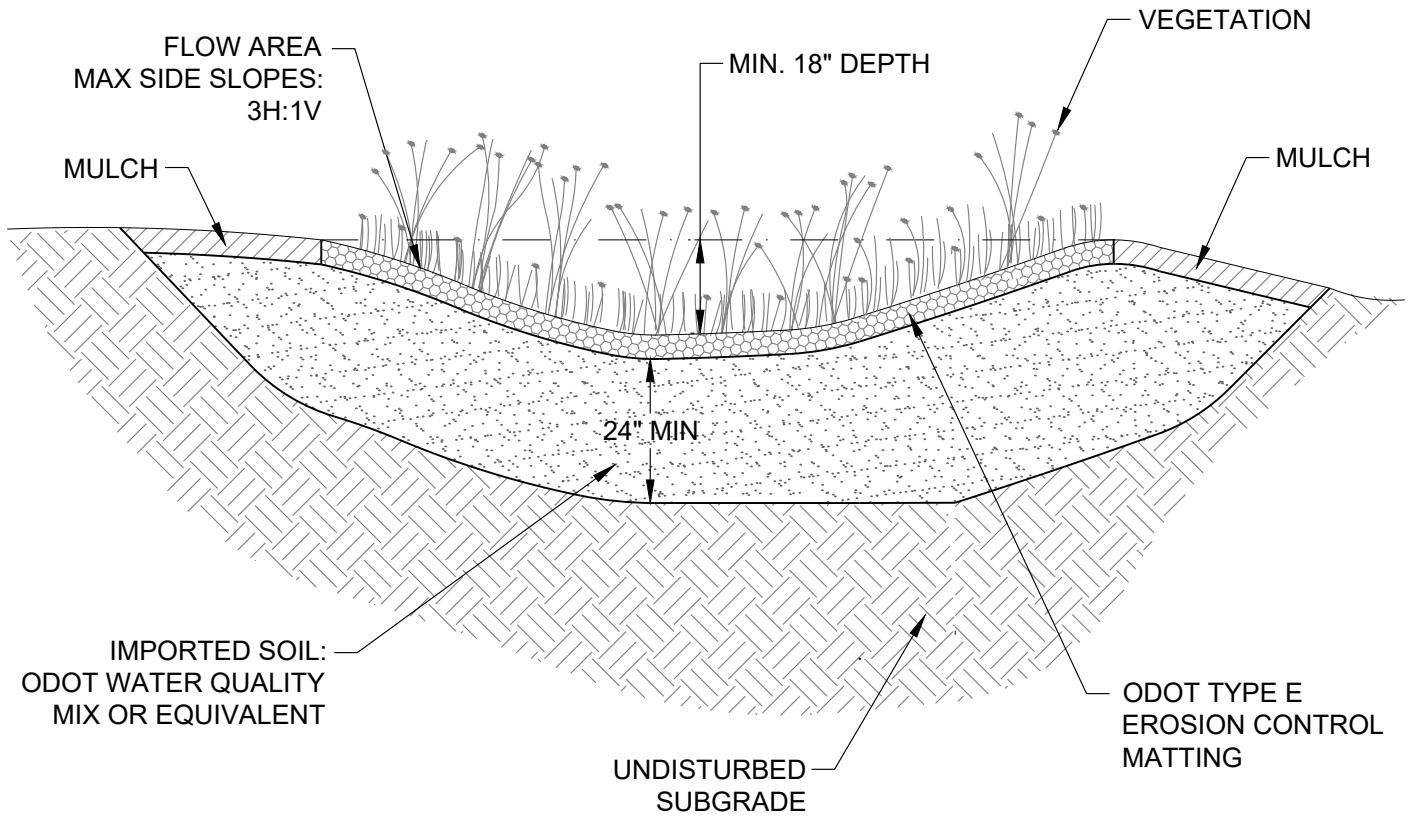

NOTE: MUST INCLUDE SIMPLIFIED APPROACH FORM

SEE SITE PLAN FOR SIZE AND LOCATION

<p>Rogue Valley Stormwater Design Manual</p>	<p>Simplified Approach Rain Garden</p>	<p>Scale: NTS</p>
--	--	-------------------

STORMWATER PLANTER – SIMPLIFIED APPROACH

This form should be used when there are no civil plans for the project.

Project Name: _____ Permit / Project #: _____

Address: _____ Map and Taxlot: _____ Building Permit: _____

Property Owner: _____ Phone: _____

Project Description: _____

STORMWATER PLANTER SIZE

New or Redeveloped Impervious Area = _____ square feet

Stormwater Planter Size (0.05 x New or Redeveloped Impervious Area) = _____ square feet

STORMWATER PLANTER LOCATION

Site Description (**attach a site plan**): _____

Proposed Location of Facility (**indicate on attached site plan**): _____

STORMWATER PLANTER DRAINAGE

How will stormwater enter the stormwater planter?

Flow across ground surface (**show slope direction of Drainage Area on the attached site plan**)

Pipe (**show pipes and catch basins on attached site plan**)

Spillway: During heavy rainstorms, when the stormwater planter fills up, where will any excess water go if the stormwater planter overflows? (**show drainage path on attached site plan**) _____

REQUIREMENTS

Property Owner to provide initials:

_____ Planter will be the size calculated above, or larger

_____ Planter will be planted with vegetation

_____ During heavy rainstorms, planter will not overflow onto a neighboring property

_____ Planter will be at least 10 feet away from building foundations

_____ All new or redeveloped impervious area will drain to the planter(s)

_____ I have read and understood the following: Even though this approach is allowed without an Oregon registered Professional Engineer (PE) or an Oregon Certified Engineering Geologist (CEG), there may be features of the project that would be best addressed by a PE or CEG to avoid negative results such as poor site drainage, high groundwater, or flooding. The project manager and owner should assess these risks to determine whether a PE or CEG should be hired to develop a site design including a grading, drainage, and or utility plan.

Owner Name: _____ Date: _____

Signature: _____

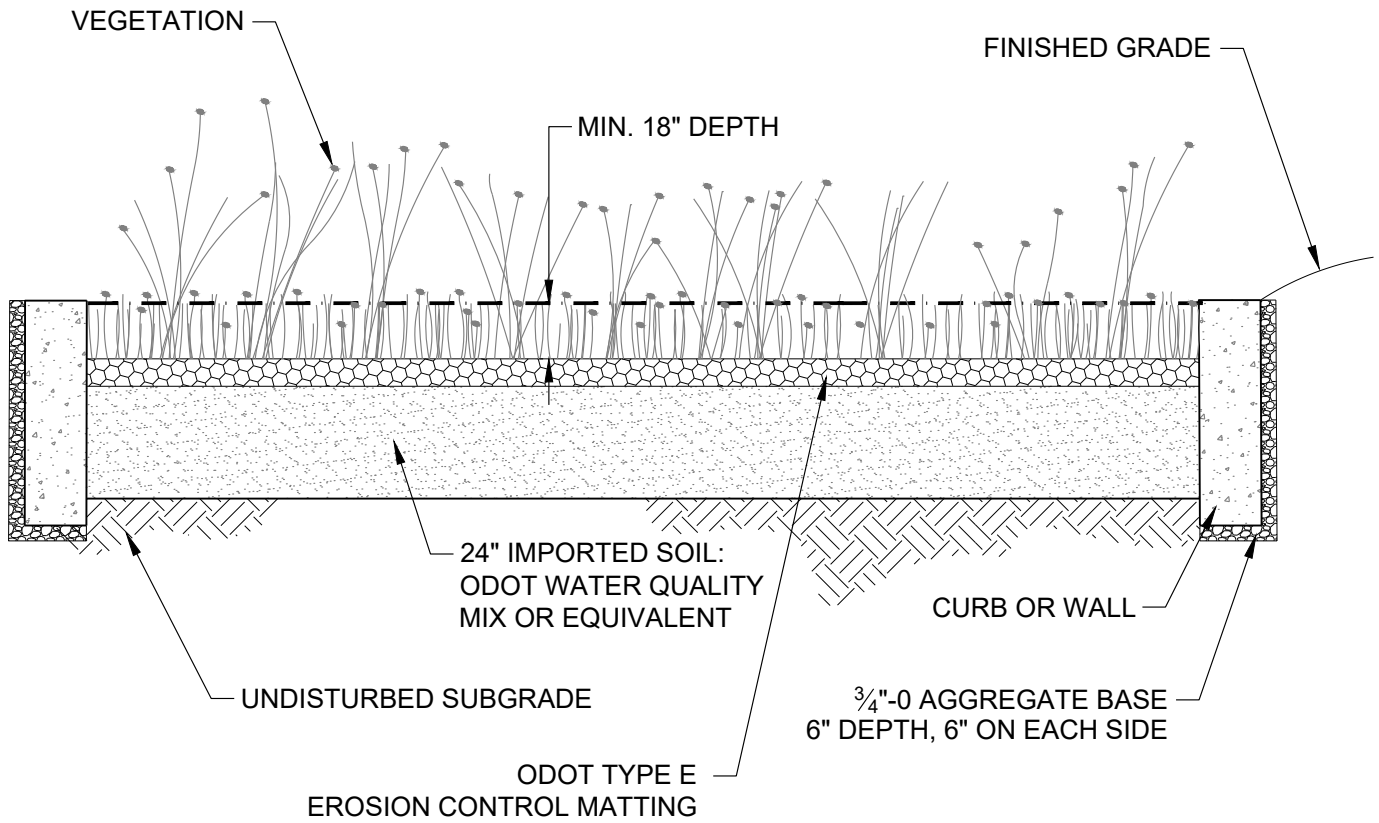

NOTE: MUST INCLUDE SIMPLIFIED APPROACH FORM

SEE SITE PLAN FOR SIZE AND LOCATION

<p>Rogue Valley Stormwater Design Manual</p>	<p>Simplified Approach Stormwater Planter</p>	<p>Scale: NTS</p>
--	---	-------------------

PERVIOUS SURFACE – SIMPLIFIED APPROACH

This form should be used when there are no civil plans for the project.

Project Name: _____ Permit / Project #: _____

Address: _____ Map and Taxlot: _____ Building Permit: _____

Property Owner: _____ Phone: _____

Project Description: _____

PERVIOUS SURFACE LOCATION, USE AND TYPE

Site Description (**attach a site plan**): _____

Proposed Location of Facility (**indicate on attached site plan**): _____

Pervious surface type: Pavers Porous Concrete Porous Asphalt Gravel/rock

Other: _____

Purposed use of pervious surface (patio, walkway, etc): _____

PERVIOUS SURFACE DRAINAGE

During heavy rainstorms, where will any excess water go if rainwater can't soak into the pervious surface?

(**Show drainage path on attached site plan**) _____

REQUIREMENTS

Property Owner to provide initials:

_____ Pervious surface will not be constructed in an area intended for vehicular use

_____ Construction of pervious surfaces will follow all manufactures recommendations/requirements, including base rock and surface thicknesses

_____ During heavy rainstorms, pervious surfaces will not cause water to flow onto a neighboring property

_____ Pervious surfaces will be at least 10 feet away from building foundations

_____ Pervious surface will only receive direct rainfall, runoff from other areas will not flow onto the pervious surface.

_____ I have read and understood the following: Even though this approach is allowed without an Oregon registered Professional Engineer (PE) or an Oregon Certified Engineering Geologist (CEG), there may be features of the project that would be best addressed by a PE or CEG to avoid negative results such as poor site drainage, high groundwater, or flooding. The project manager and owner should assess these risks to determine whether a PE or CEG should be hired to develop a site design including a grading, drainage, and or utility plan.

Owner Name: _____ Date: _____

Signature: _____

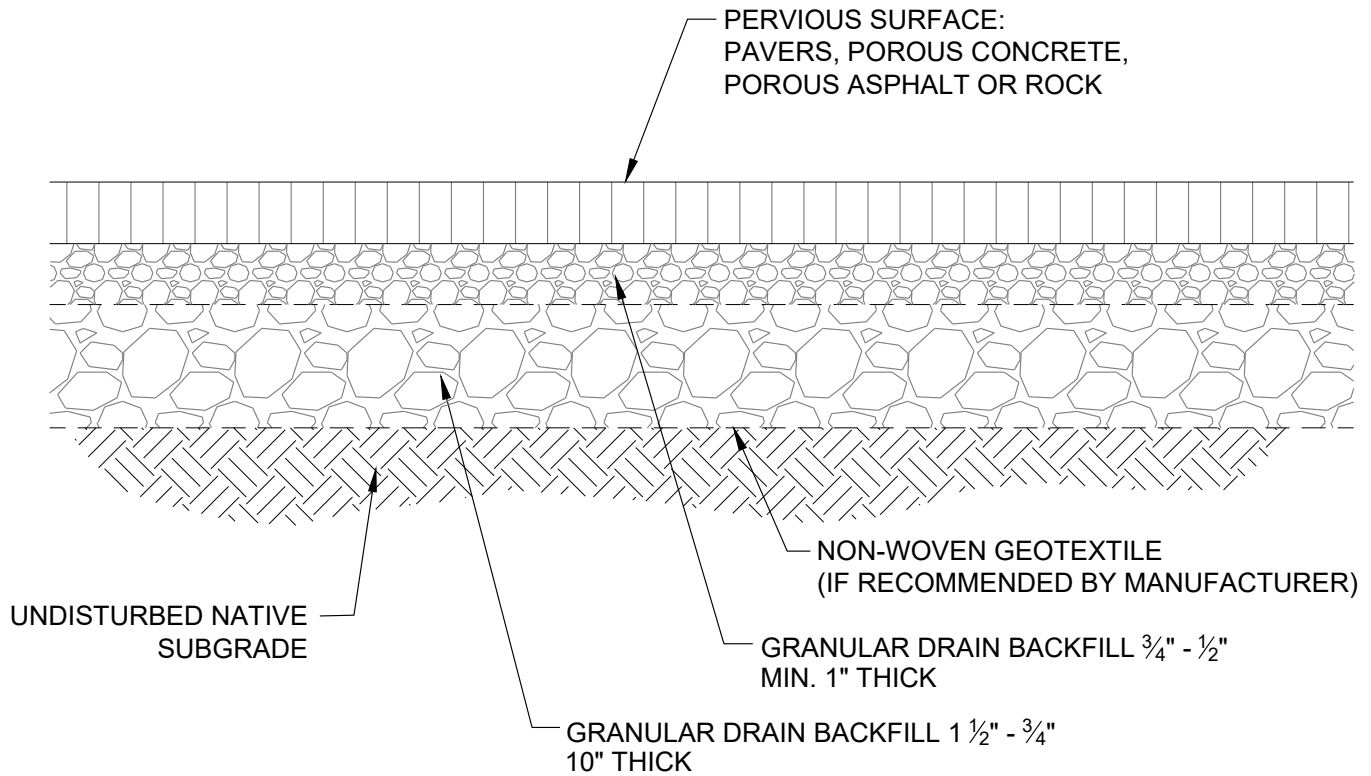

NOTES

1. STRUCTURAL AND INSTALLATION SHOULD BE IN ACCORDANCE WITH MANUFACTURER RECOMMENDATIONS AND REQUIREMENTS
2. UNLESS OTHERWISE APPROVED, GRANULAR DRAIN BACKFILL SHALL BE NO LARGER THAN $1\frac{1}{2}$ ".

SEE SITE PLAN FOR SURFACE, LOCATION, AND DIMENSIONS

Rogue Valley
Stormwater Design
Manual

Simplified Approach
Pervious Surface

Scale: NTS

VEGETATED FILTER STRIP – SIMPLIFIED APPROACH

This form should be used when there are no civil plans for the project.

Project Name: _____ Permit / Project #: _____

Address: _____ Map and Taxlot: _____ Building Permit: _____

Property Owner: _____ Phone: _____

Project Description: _____

VEGETATED FILTER STRIP LOCATION AND USE

Site Description (attach a site plan): _____

Vegetated filter strips are installed alongside impervious surfaces such as roadways, walk ways, and patios. What type of surface is being built? Road Path Patio Other: _____

Proposed Location of Facility (indicate on attached site plan): _____

VEGETATED FILTER STRIP SIZE

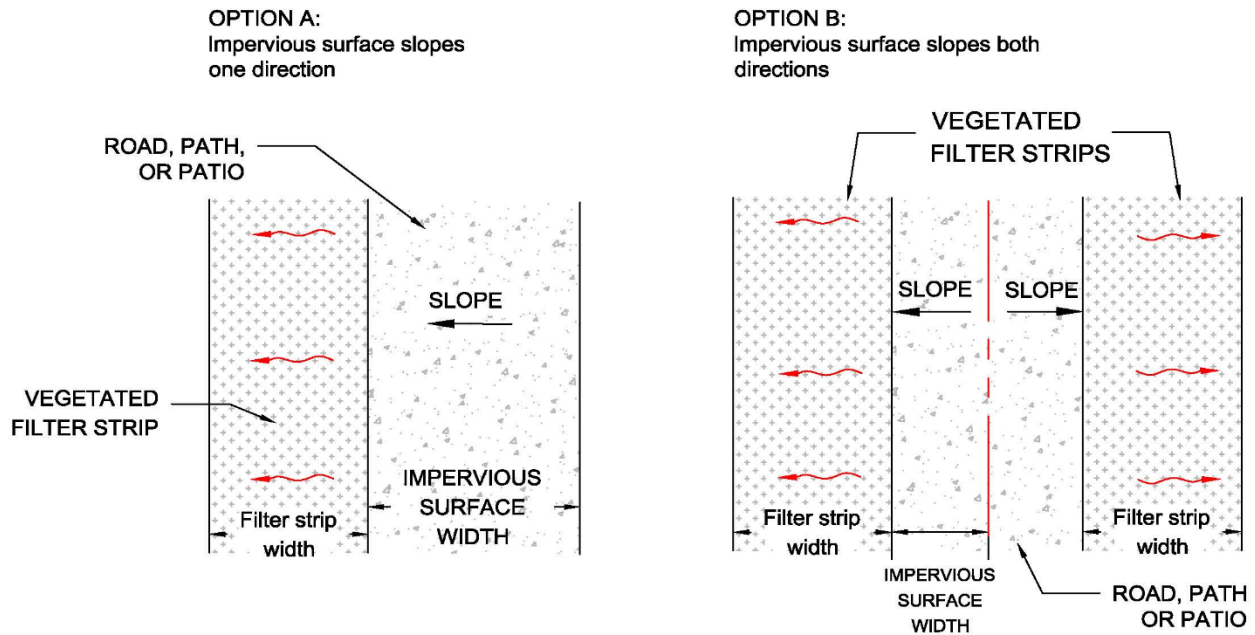

Impervious surface width: _____ feet (Maximum of 75 feet)

Impervious surface slope to Filter Strip: _____ (Max 5%)

Filter strip slope away from impervious surface _____ (Max 10%)

Maximum longitudinal slope of impervious surface and filter strip _____ (Max 4%)

Vegetated filter strip width Calculation: Impervious surface width _____ feet x 0.5 = _____ feet

REQUIREMENTS

Property Owner to provide initials:

_____ Vegetated filter strip will be the size calculated above, or larger

_____ Vegetated filter strip will not slope toward building foundations

_____ Maximum slopes of the impervious surfaces and filter strips do not exceed maximums stated.

_____ I have read and understood the following: Even though this approach is allowed without an Oregon registered Professional Engineer (PE) or an Oregon Certified Engineering Geologist (CEG), there may be features of the project that would be best addressed by a PE or CEG to avoid negative results such as poor site drainage, high groundwater, or flooding. The project manager and owner should assess these risks to determine whether a PE or CEG should be hired to develop a site design including a grading, drainage, and or utility plan.

Owner Name: _____ Date: _____

Signature: _____

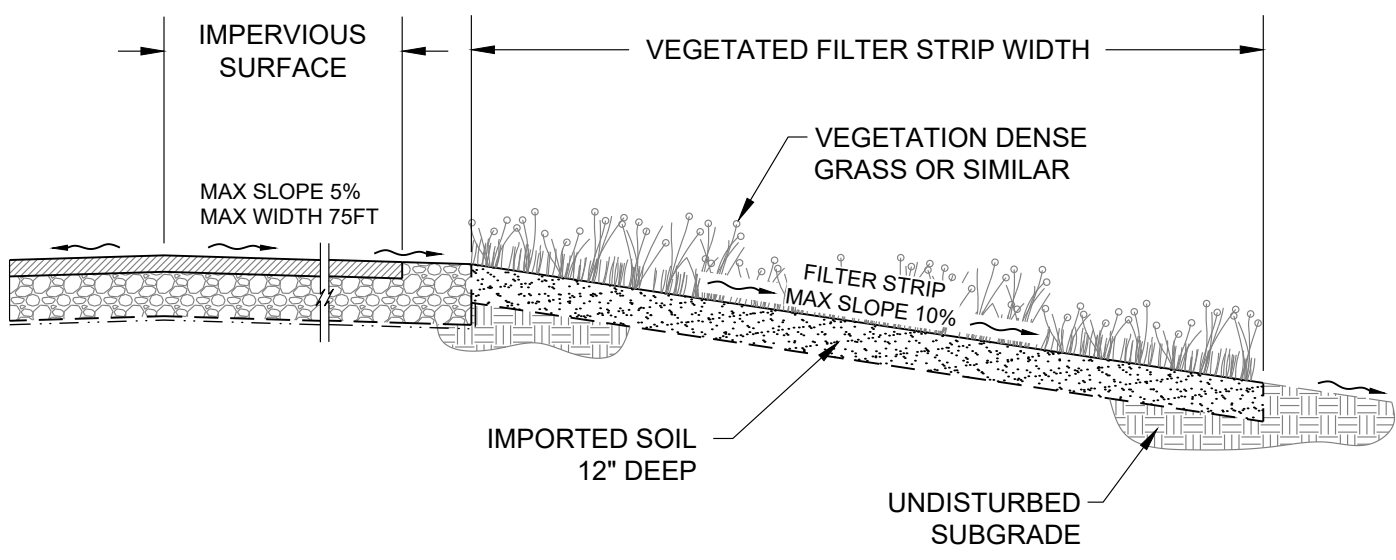
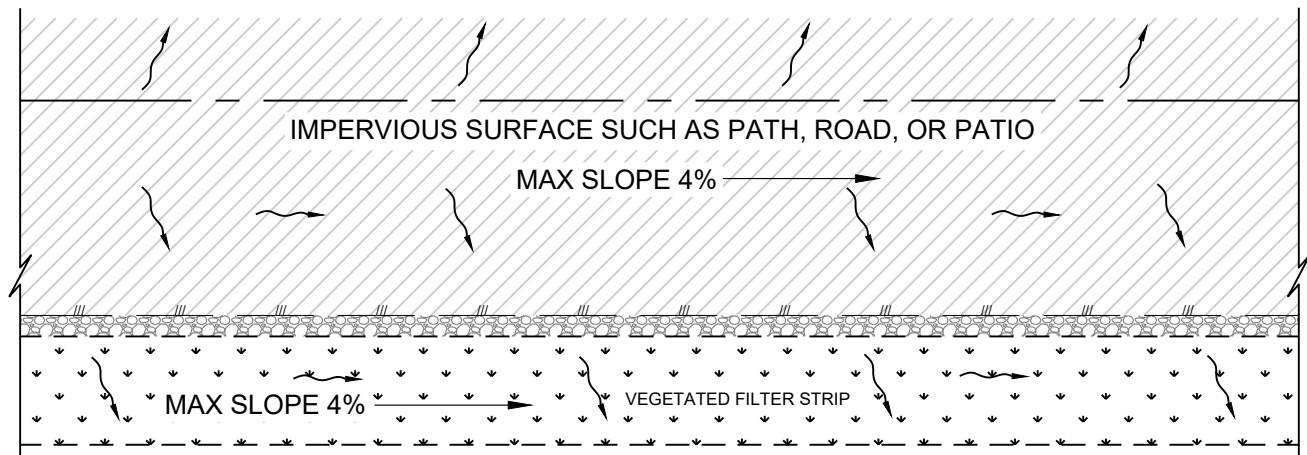

SEE SITE PLAN FOR SIZE AND LOCATION

<p>Rogue Valley Stormwater Design Manual</p>	<p>Simplified Approach Vegetated Filter Strip</p>	<p>Scale: NTS</p>
--	---	-------------------

DISCONNECTED DOWNSPOUTS – TO PERVIOUS AREA

SIMPLIFIED APPROACH

This form should be used when there are no civil plans for the project.

Project Name: _____ Permit / Project #: _____

Address: _____ Map and Taxlot: _____ Building Permit: _____

Property Owner: _____ Phone: _____

Project Description: _____

Site Description (**attach a site plan**): _____

PERVIOUS AREA(S) SIZE AND LOCATION(S)

Total roof area = _____

Number of downspouts = _____ (**maximum roof area per downspout = 700 square feet**)

Pervious area required (roof area x 0.05) = _____

Describe downspout location and pervious surface locations:

PROJECT SITE DRAINAGE

Average lot slope: _____ (**must be less than 10%**)

Spillway: During heavy rainstorms, if water can't soak into the ground, where will any excess water go? (**show drainage path on attached site plan**) _____

REQUIREMENTS

Property Owner to provide initials:

_____ Discharge from downspouts will not flow over an impervious surface (such as pavement)

_____ Downspouts will discharge at least five feet away from building foundations and property lines

_____ Downspouts and pervious area will be installed per the attached detail

_____ I have read and understood the following: Even though this approach is allowed without an Oregon registered Professional Engineer (PE) or an Oregon Certified Engineering Geologist (CEG), there may be features of the project that would be best addressed by a PE or CEG to avoid negative results such as poor site drainage, high groundwater, or flooding. The project manager and owner should assess these risks to determine whether a PE or CEG should be hired to develop a site design including a grading, drainage, and or utility plan.

Owner Name: _____ Date: _____

Signature: _____

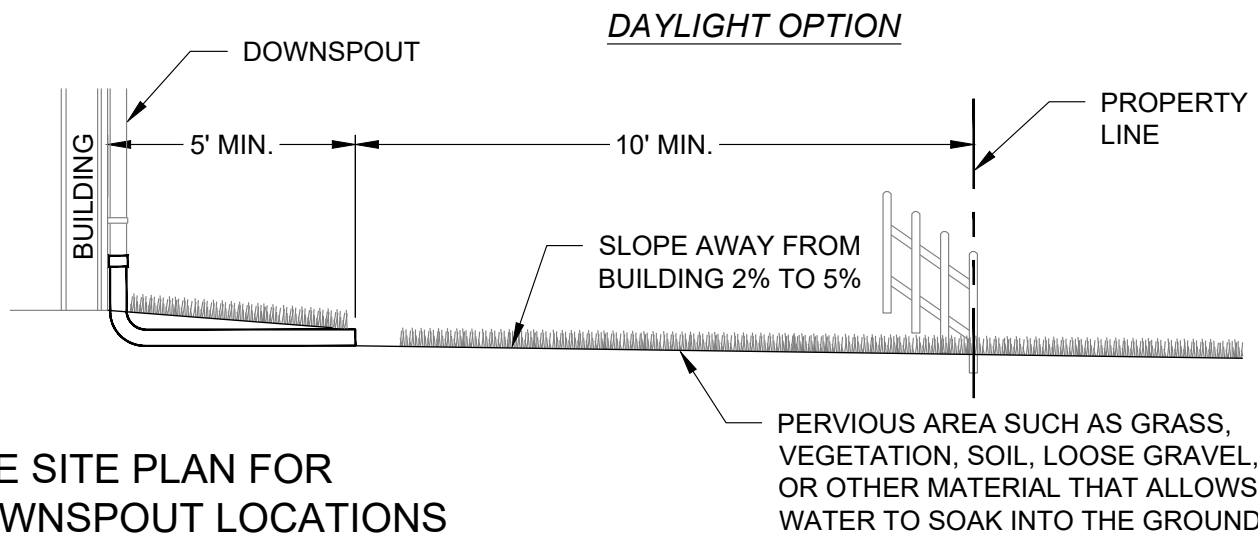
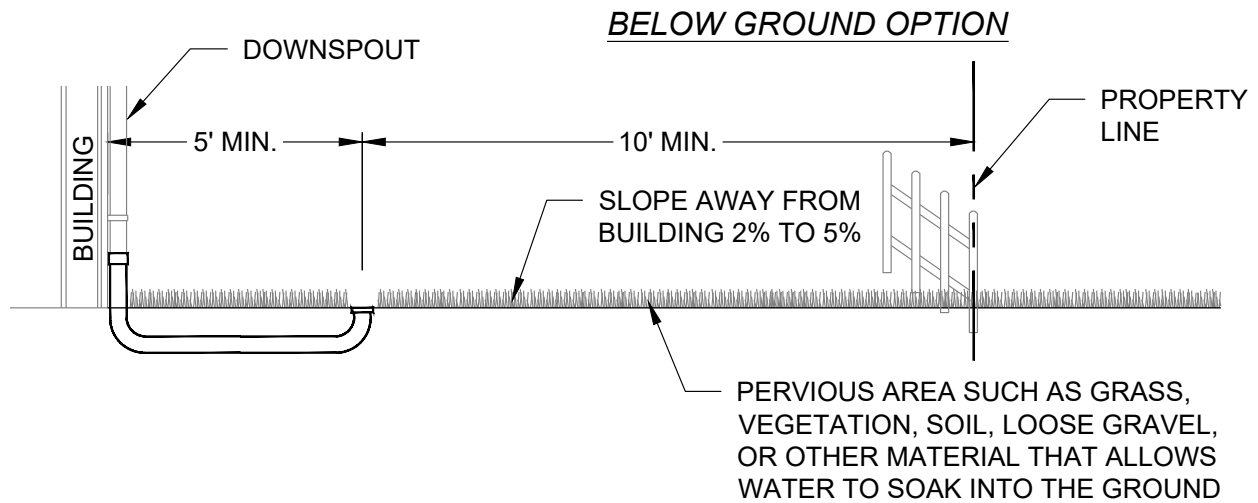
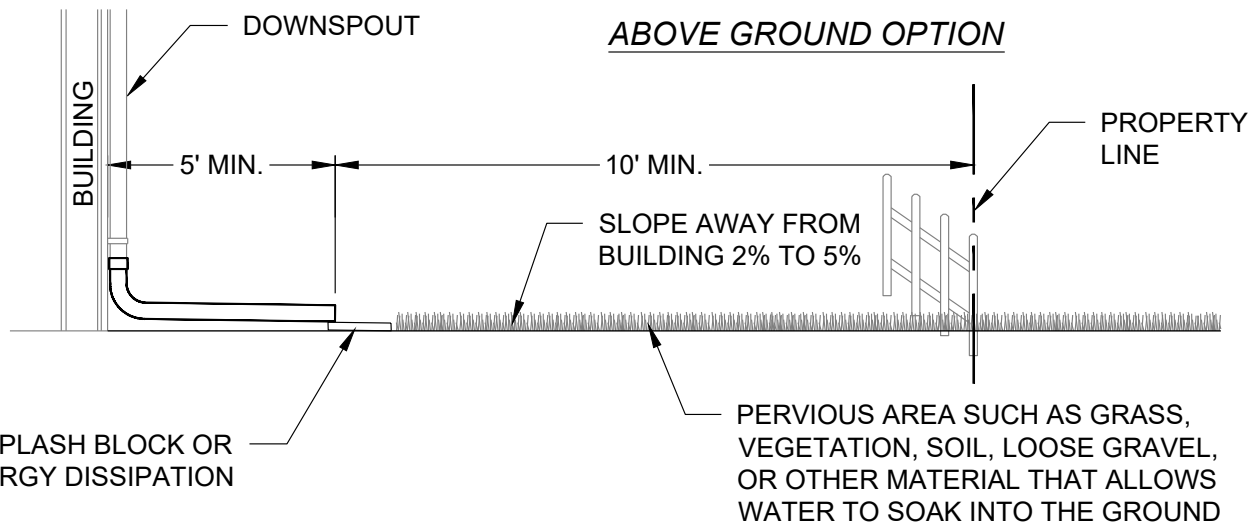

SEE SITE PLAN FOR
DOWNSPOUT LOCATIONS

<p>Rogue Valley Stormwater Design Manual</p>	<p>Simplified Approach Disconnected Downspout to Pervious Area</p>	<p>Scale: NTS</p>
--	--	-------------------

DISCONNECTED DOWNSPOUTS – TO INFILTRATION TRENCH

SIMPLIFIED APPROACH

This form should be used when there are no civil plans for the project.

Project Name: _____ Permit / Project #: _____

Address: _____ Map and Taxlot: _____ Building Permit: _____

Property Owner: _____ Phone: _____

Project Description: _____

Site Description (**attach a site plan**): _____

PERVIOUS AREA(S) SIZE AND LOCATION(S)

Total roof area = _____

Number of downspouts = _____ (**maximum roof area per downspout = 700 square feet**)

PROJECT SITE DRAINAGE

Average lot slope: _____ (**must be less than 10%**)

Spillway: During heavy rainstorms, if water can't soak into the ground, where will any excess water go? (**show drainage path on attached site plan**) _____

REQUIREMENTS

Property Owner to provide initials:

_____ Downspouts and infiltration trench will be installed per the attached detail

_____ Downspouts will discharge into the infiltration trench at least 10 feet away from building foundations and property lines

_____ A clean out box will be added near the building

_____ I have read and understood the following: Even though this approach is allowed without an Oregon registered Professional Engineer (PE) or an Oregon Certified Engineering Geologist (CEG), there may be features of the project that would be best addressed by a PE or CEG to avoid negative results such as poor site drainage, high groundwater, or flooding. The project manager and owner should assess these risks to determine whether a PE or CEG should be hired to develop a site design including a grading, drainage, and or utility plan.

Owner Name: _____ Date: _____

Signature: _____

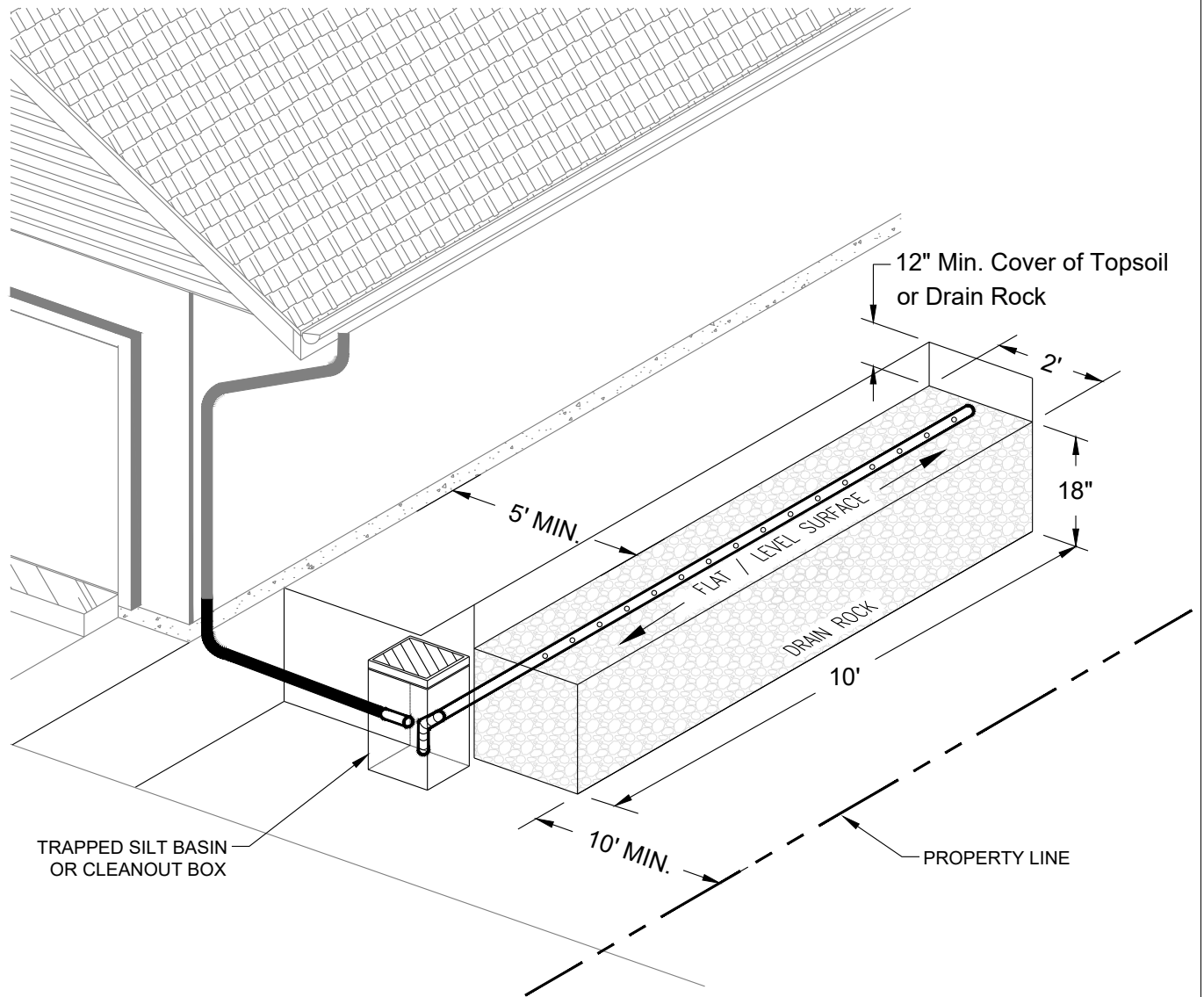

NOTES

- 1. Without prior approval, rock shall be clean 3/4" to 2" uniformly graded drain rock.
- 2. Non-woven geotextile required around infiltration trench.

SEE SITE PLAN FOR LOCATION

<p>Rogue Valley Stormwater Design Manual</p>	<p>Simplified Approach Disconnected Downspout to Infiltration Trench</p>	<p>Scale: NTS</p>
--	--	-------------------

Appendix C - Santa Barbara Urban Hydrograph Example

2.3.3 Hydrograph Synthesis – Santa Barbara Urban Hydrograph

The Santa Barbara Urban Hydrograph (SBUH) method is described below. It is given here as a guideline only, as it is only one of the many SCS-based hydrograph methods that are available for use.

The SBUH method, like the Soil Conservation Service Unit Hydrograph (SCSUH) method, is based on the curve number (CN) approach, and also uses SCS equations for computing soil absorption and precipitation excess. The SCSUH method works by converting the incremental runoff depths (precipitation excess) for a given basin and design storm into a runoff hydrograph via application of a dimensionless unit hydrograph. The shape of the SCS unit hydrograph (time to peak, time base, and peak) are determined by a single parameter - the basin time of concentration. The SBUH method, on the other hand, converts the incremental runoff depths into instantaneous hydrographs that are then routed through an imaginary reservoir with a time delay equal to the basin time of concentration.

The SBUH method was developed by the Santa Barbara County Flood Control and Water Conservation District, California. The SBUH method directly computes a runoff hydrograph without going through an intermediate process (unit hydrograph) as the SCSUH method does. By comparison, the calculation steps of the SBUH method are much simpler and can be programmed on a calculator or a spreadsheet program.

The SBUH method uses two steps to synthesize the runoff hydrograph:

- Step one - computing the instantaneous hydrograph, and
- Step two - computing the runoff hydrograph.

The instantaneous hydrograph, $I(t)$, in cfs, at each time step, dt , is computed as follows:

$$I_t = 60.5 R_t A / d_t$$

Where R_t = total runoff depth (both impervious and pervious runoffs) at time increment dt , in inches (also known as precipitation excess)

A = area in acres

d_t = time interval in minutes*

*NOTE: A maximum time interval of 10 minutes should be used for all design storms of 24-hour duration. A maximum time interval of 60 minutes should be used for the 100-year, 7-day design storm.

The runoff hydrograph, Q_t , is then obtained by routing the instantaneous hydrograph I_t , through an imaginary reservoir with a time delay equal to the time of concentration, T_c , of the drainage basin. The following equation estimates the routed flow, Q_t :

$$Q_{t+1} = Q_t + w[I_t + I_{t+1} - 2Q_t]$$

$$\text{Where: } w = d_t / (2T_c + d_t)$$

$$d_t = \text{time interval in minutes}$$

Example: To illustrate the SBUH method, Tables 2.6 and 2.7 show runoff hydrograph values computed by this method for both existing and developed conditions. Figure 2.3 illustrates the hydrographs for existing and developed conditions. Note, this example was prepared using the Excel 5.0 spreadsheet program and illustrates how the method can be used with a personal computer. Copies of this program and a Fortran version are available (with minimal documentation) from King County Surface Water Management Division.

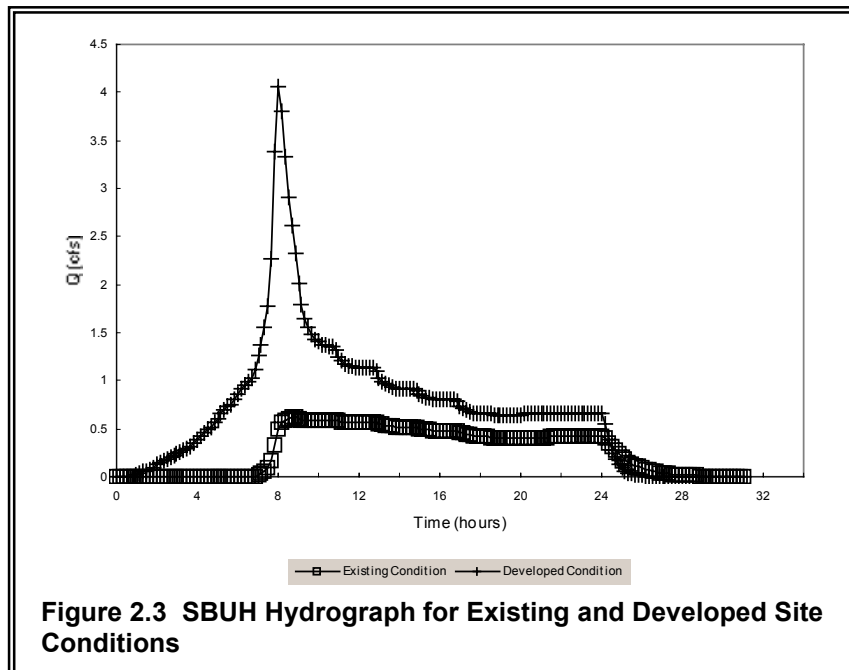

Table 2.6
SBUH Values for Existing Site Condition

Given: Area = 10 acres P = 2.9 inches (10-yr, 24-hr. event) dt = 10 minutes
 PERVIOUS AREA: Area = 10 acres CN = 74 S = 3.513514 0.2S = 0.70
 IMPERVIOUS AREA: Area = 0 acres CN = 98 S = 0.204082 0.2S = 0.04
 Tc = 73 minutes w = 0.064103 where S = potential maximum natural detention (as defined earlier)

- Column (1) = Time Increment
- Column (2) = Time (min)
- Column (3) = Type IA Storm Distribution
- Column (4) = Column (3) * P
- Column (5) = Accumulated sum of Column (4)
- Column (6) = If (P < 0.2S) = 0, If (P > 0.2S) = (Column (5) - 0.2S)^2 / (Column (5) + 0.8S), where the PERVIOUS AREA S value is used
- Column (7) = Column (6) of the present step - Column (6) of the previous step
- Column (8) = Same as Column (6) except use IMPERVIOUS AREA S value
- Column (9) = Column (8) of the present step - Column (8) of the previous step
- Column (10) = (PERVIOUS AREA/TOTAL AREA)*Column (7)+(IMPERVIOUS AREA/TOTAL AREA)*Column (9)
- Column (11) = (60.5*Column (10)*Total Area)/dt, where dt = 10 or 60 minutes
- Column (12) = Column (12) of previous time step + w * [(Column (11) of previous time step + Column (11) of present time step) - (2 * Column (12) of previous time step)] where w = routing constant = dt/(2Tc + dt) = 0.0641

(1) Time Increment	(2) Time (minute)	(3) Rainfall Distrib. (fraction)	(4) Incre. Rainfall (inches)	(5) Accumul. Rainfall (inches)	(6) PERVIOUS		(8) IMPERVIOUS		(10) Total Runoff (inches)	(11) Instant Flowrate (cfs)	(12) Design Flowrate (cfs)
					Accum. Runoff (inches)	Incr. Runoff (inches)	Accum. Runoff (inches)	Incr. Runoff (inches)			
1	0	0	0	0	0	0	0	0	0	0.0	0.0
2	10	0.004	0.012	0.012	0.000	0.000	0.000	0.000	0.000	0.0	0.0
3	20	0.004	0.012	0.023	0.000	0.000	0.000	0.000	0.000	0.0	0.0
4	30	0.004	0.012	0.035	0.000	0.000	0.000	0.000	0.000	0.0	0.0
5	40	0.004	0.012	0.046	0.000	0.000	0.000	0.000	0.000	0.0	0.0
6	50	0.004	0.012	0.058	0.000	0.000	0.001	0.001	0.000	0.0	0.0
7	60	0.004	0.012	0.070	0.000	0.000	0.004	0.002	0.000	0.0	0.0
8	70	0.004	0.012	0.081	0.000	0.000	0.007	0.003	0.000	0.0	0.0
9	80	0.004	0.012	0.093	0.000	0.000	0.011	0.004	0.000	0.0	0.0
10	90	0.004	0.012	0.104	0.000	0.000	0.015	0.005	0.000	0.0	0.0
11	100	0.004	0.012	0.116	0.000	0.000	0.020	0.005	0.000	0.0	0.0
12	110	0.005	0.015	0.131	0.000	0.000	0.027	0.007	0.000	0.0	0.0
13	120	0.005	0.015	0.145	0.000	0.000	0.035	0.008	0.000	0.0	0.0
14	130	0.005	0.015	0.160	0.000	0.000	0.044	0.008	0.000	0.0	0.0
15	140	0.005	0.015	0.174	0.000	0.000	0.053	0.009	0.000	0.0	0.0
16	150	0.005	0.015	0.189	0.000	0.000	0.062	0.009	0.000	0.0	0.0
17	160	0.005	0.015	0.203	0.000	0.000	0.072	0.010	0.000	0.0	0.0
18	170	0.006	0.017	0.220	0.000	0.000	0.084	0.012	0.000	0.0	0.0
19	180	0.006	0.017	0.238	0.000	0.000	0.097	0.013	0.000	0.0	0.0
20	190	0.006	0.017	0.255	0.000	0.000	0.110	0.013	0.000	0.0	0.0
21	200	0.006	0.017	0.273	0.000	0.000	0.123	0.013	0.000	0.0	0.0
22	210	0.006	0.017	0.290	0.000	0.000	0.137	0.014	0.000	0.0	0.0
23	220	0.006	0.017	0.307	0.000	0.000	0.151	0.014	0.000	0.0	0.0
24	230	0.007	0.020	0.328	0.000	0.000	0.168	0.017	0.000	0.0	0.0
25	240	0.007	0.020	0.348	0.000	0.000	0.185	0.017	0.000	0.0	0.0
26	250	0.007	0.020	0.368	0.000	0.000	0.202	0.017	0.000	0.0	0.0
27	260	0.007	0.020	0.389	0.000	0.000	0.219	0.017	0.000	0.0	0.0
28	270	0.007	0.020	0.409	0.000	0.000	0.237	0.018	0.000	0.0	0.0
29	280	0.007	0.020	0.429	0.000	0.000	0.255	0.018	0.000	0.0	0.0
30	290	0.008	0.024	0.453	0.000	0.000	0.276	0.021	0.000	0.0	0.0
31	300	0.008	0.024	0.477	0.000	0.000	0.297	0.021	0.000	0.0	0.0
32	310	0.008	0.024	0.501	0.000	0.000	0.318	0.021	0.000	0.0	0.0
33	320	0.008	0.024	0.524	0.000	0.000	0.340	0.022	0.000	0.0	0.0
34	330	0.008	0.024	0.548	0.000	0.000	0.362	0.022	0.000	0.0	0.0
35	340	0.008	0.024	0.572	0.000	0.000	0.384	0.022	0.000	0.0	0.0
36	350	0.010	0.028	0.599	0.000	0.000	0.409	0.026	0.000	0.0	0.0
37	360	0.010	0.028	0.627	0.000	0.000	0.435	0.026	0.000	0.0	0.0
38	370	0.010	0.028	0.655	0.000	0.000	0.461	0.026	0.000	0.0	0.0

(1) Time Increment	(2) Time (minute)	(3) Rainfall Distrib. (fraction)	(4) Incre. Rainfall (inches)	(5) Accumul. Rainfall (inches)	(6) PERVIOUS		(7) IMPERVIOUS		(10) Total Runoff (inches)	(11) Instant Flowrate (cfs)	(12) Design Flowrate (cfs)
					Accum. Runoff (inches)	Incre. Runoff (inches)	Accum. Runoff (inches)	Incre. Runoff (inches)			
39	380	0.010	0.028	0.682	0.000	0.000	0.486	0.026	0.000	0.0	0.0
40	390	0.010	0.028	0.710	0.000	0.000	0.512	0.026	0.000	0.0	0.0
41	400	0.010	0.028	0.737	0.000	0.000	0.539	0.026	0.000	0.0	0.0
42	410	0.013	0.039	0.776	0.001	0.001	0.575	0.037	0.001	0.1	0.0
43	420	0.013	0.039	0.815	0.003	0.002	0.613	0.037	0.002	0.1	0.0
44	430	0.013	0.039	0.854	0.006	0.003	0.650	0.037	0.003	0.2	0.0
45	440	0.018	0.052	0.906	0.011	0.005	0.700	0.050	0.005	0.3	0.1
46	450	0.018	0.052	0.958	0.017	0.006	0.750	0.050	0.006	0.4	0.1
47	460	0.034	0.099	1.057	0.032	0.015	0.846	0.096	0.015	0.9	0.2
48	470	0.054	0.157	1.213	0.065	0.032	0.999	0.153	0.032	2.0	0.3
49	480	0.027	0.078	1.292	0.085	0.020	1.075	0.077	0.020	1.2	0.5
50	490	0.018	0.052	1.344	0.099	0.014	1.127	0.051	0.014	0.9	0.6
51	500	0.013	0.039	1.383	0.110	0.011	1.165	0.038	0.011	0.7	0.6
52	510	0.013	0.039	1.422	0.122	0.012	1.203	0.038	0.012	0.7	0.6
53	520	0.013	0.039	1.460	0.134	0.012	1.241	0.038	0.012	0.7	0.6
54	530	0.009	0.026	1.486	0.143	0.008	1.266	0.025	0.008	0.5	0.6
55	540	0.009	0.026	1.511	0.151	0.009	1.291	0.025	0.009	0.5	0.6
56	550	0.009	0.026	1.537	0.160	0.009	1.317	0.025	0.009	0.5	0.6
57	560	0.009	0.026	1.563	0.169	0.009	1.342	0.025	0.009	0.5	0.6
58	570	0.009	0.026	1.588	0.178	0.009	1.367	0.025	0.009	0.6	0.6
59	580	0.009	0.026	1.614	0.188	0.009	1.392	0.025	0.009	0.6	0.6
60	590	0.009	0.026	1.639	0.197	0.010	1.417	0.025	0.010	0.6	0.6
61	600	0.009	0.026	1.665	0.207	0.010	1.442	0.025	0.010	0.6	0.6
62	610	0.009	0.026	1.690	0.217	0.010	1.468	0.025	0.010	0.6	0.6
63	620	0.009	0.026	1.716	0.227	0.010	1.493	0.025	0.010	0.6	0.6
64	630	0.009	0.026	1.741	0.237	0.010	1.518	0.025	0.010	0.6	0.6
65	640	0.009	0.026	1.767	0.247	0.010	1.543	0.025	0.010	0.6	0.6
66	650	0.007	0.021	1.788	0.256	0.009	1.564	0.021	0.009	0.5	0.6
67	660	0.007	0.021	1.808	0.265	0.009	1.585	0.021	0.009	0.5	0.6
68	670	0.007	0.021	1.829	0.274	0.009	1.605	0.021	0.009	0.5	0.6
69	680	0.007	0.021	1.850	0.283	0.009	1.626	0.021	0.009	0.5	0.6
70	690	0.007	0.021	1.871	0.292	0.009	1.647	0.021	0.009	0.5	0.6
71	700	0.007	0.021	1.892	0.301	0.009	1.667	0.021	0.009	0.6	0.6
72	710	0.007	0.021	1.913	0.310	0.009	1.688	0.021	0.009	0.6	0.6
73	720	0.007	0.021	1.934	0.319	0.009	1.709	0.021	0.009	0.6	0.6
74	730	0.007	0.021	1.955	0.329	0.009	1.729	0.021	0.009	0.6	0.6
75	740	0.007	0.021	1.975	0.338	0.010	1.750	0.021	0.010	0.6	0.6
76	750	0.007	0.021	1.996	0.348	0.010	1.771	0.021	0.010	0.6	0.6
77	760	0.007	0.021	2.017	0.358	0.010	1.791	0.021	0.010	0.6	0.6
78	770	0.006	0.017	2.034	0.366	0.008	1.808	0.016	0.008	0.5	0.6
79	780	0.006	0.017	2.050	0.374	0.008	1.824	0.016	0.008	0.5	0.6
80	790	0.006	0.017	2.067	0.382	0.008	1.841	0.016	0.008	0.5	0.5
81	800	0.006	0.017	2.083	0.389	0.008	1.857	0.016	0.008	0.5	0.5
82	810	0.006	0.017	2.100	0.398	0.008	1.873	0.016	0.008	0.5	0.5
83	820	0.006	0.017	2.116	0.406	0.008	1.890	0.016	0.008	0.5	0.5
84	830	0.006	0.017	2.133	0.414	0.008	1.906	0.016	0.008	0.5	0.5
85	840	0.006	0.017	2.149	0.422	0.008	1.923	0.016	0.008	0.5	0.5
86	850	0.006	0.017	2.166	0.430	0.008	1.939	0.016	0.008	0.5	0.5
87	860	0.006	0.017	2.183	0.439	0.008	1.955	0.016	0.008	0.5	0.5
88	870	0.006	0.017	2.199	0.447	0.008	1.972	0.016	0.008	0.5	0.5
89	880	0.006	0.017	2.216	0.455	0.008	1.988	0.016	0.008	0.5	0.5
90	890	0.005	0.015	2.230	0.463	0.007	2.003	0.014	0.007	0.4	0.5
91	900	0.005	0.015	2.245	0.470	0.007	2.017	0.014	0.007	0.5	0.5
92	910	0.005	0.015	2.259	0.478	0.008	2.031	0.014	0.008	0.5	0.5
93	920	0.005	0.015	2.274	0.485	0.008	2.046	0.014	0.008	0.5	0.5
94	930	0.005	0.015	2.288	0.493	0.008	2.060	0.014	0.008	0.5	0.5
95	940	0.005	0.015	2.303	0.501	0.008	2.075	0.014	0.008	0.5	0.5

(1) Time Increment	(2) Time (minute)	(3) Rainfall Distrib. (fraction)	(4) Incre. Rainfall (inches)	(5) Accumul. Rainfall (inches)	(6) PERVIOUS		(8) IMPERVIOUS		(10) Total Runoff (inches)	(11) Instant Flowrate (cfs)	(12) Design Flowrate (cfs)
					Accum. Runoff (inches)	Incre. Runoff (inches)	Accum. Runoff (inches)	Incre. Runoff (inches)			
96	950	0.005	0.015	2.317	0.508	0.008	2.089	0.014	0.008	0.5	0.5
97	960	0.005	0.015	2.332	0.516	0.008	2.103	0.014	0.008	0.5	0.5
98	970	0.005	0.015	2.346	0.524	0.008	2.118	0.014	0.008	0.5	0.5
99	980	0.005	0.015	2.361	0.532	0.008	2.132	0.014	0.008	0.5	0.5
100	990	0.005	0.015	2.375	0.539	0.008	2.147	0.014	0.008	0.5	0.5
101	1000	0.005	0.015	2.390	0.547	0.008	2.161	0.014	0.008	0.5	0.5
102	1010	0.004	0.012	2.401	0.554	0.006	2.173	0.012	0.006	0.4	0.5
103	1020	0.004	0.012	2.413	0.560	0.006	2.184	0.012	0.006	0.4	0.5
104	1030	0.004	0.012	2.424	0.566	0.006	2.196	0.012	0.006	0.4	0.4
105	1040	0.004	0.012	2.436	0.573	0.006	2.207	0.012	0.006	0.4	0.4
106	1050	0.004	0.012	2.448	0.579	0.006	2.219	0.012	0.006	0.4	0.4
107	1060	0.004	0.012	2.459	0.585	0.006	2.230	0.012	0.006	0.4	0.4
108	1070	0.004	0.012	2.471	0.592	0.006	2.242	0.012	0.006	0.4	0.4
109	1080	0.004	0.012	2.482	0.598	0.006	2.253	0.012	0.006	0.4	0.4
110	1090	0.004	0.012	2.494	0.605	0.007	2.265	0.012	0.007	0.4	0.4
111	1100	0.004	0.012	2.506	0.611	0.007	2.276	0.012	0.007	0.4	0.4
112	1110	0.004	0.012	2.517	0.618	0.007	2.288	0.012	0.007	0.4	0.4
113	1120	0.004	0.012	2.529	0.625	0.007	2.299	0.012	0.007	0.4	0.4
114	1130	0.004	0.012	2.540	0.631	0.007	2.311	0.012	0.007	0.4	0.4
115	1140	0.004	0.012	2.552	0.638	0.007	2.322	0.012	0.007	0.4	0.4
116	1150	0.004	0.012	2.564	0.644	0.007	2.334	0.012	0.007	0.4	0.4
117	1160	0.004	0.012	2.575	0.651	0.007	2.346	0.012	0.007	0.4	0.4
118	1170	0.004	0.012	2.587	0.658	0.007	2.357	0.012	0.007	0.4	0.4
119	1180	0.004	0.012	2.598	0.664	0.007	2.369	0.012	0.007	0.4	0.4
120	1190	0.004	0.012	2.610	0.671	0.007	2.380	0.012	0.007	0.4	0.4
121	1200	0.004	0.012	2.622	0.678	0.007	2.392	0.012	0.007	0.4	0.4
122	1210	0.004	0.012	2.633	0.685	0.007	2.403	0.012	0.007	0.4	0.4
123	1220	0.004	0.012	2.645	0.691	0.007	2.415	0.012	0.007	0.4	0.4
124	1230	0.004	0.012	2.656	0.698	0.007	2.426	0.012	0.007	0.4	0.4
125	1240	0.004	0.012	2.668	0.705	0.007	2.438	0.012	0.007	0.4	0.4
126	1250	0.004	0.012	2.680	0.712	0.007	2.449	0.012	0.007	0.4	0.4
127	1260	0.004	0.012	2.691	0.719	0.007	2.461	0.012	0.007	0.4	0.4
128	1270	0.004	0.012	2.703	0.726	0.007	2.472	0.012	0.007	0.4	0.4
129	1280	0.004	0.012	2.714	0.732	0.007	2.484	0.012	0.007	0.4	0.4
130	1290	0.004	0.012	2.726	0.739	0.007	2.496	0.012	0.007	0.4	0.4
131	1300	0.004	0.012	2.738	0.746	0.007	2.507	0.012	0.007	0.4	0.4
132	1310	0.004	0.012	2.749	0.753	0.007	2.519	0.012	0.007	0.4	0.4
133	1320	0.004	0.012	2.761	0.760	0.007	2.530	0.012	0.007	0.4	0.4
134	1330	0.004	0.012	2.772	0.767	0.007	2.542	0.012	0.007	0.4	0.4
135	1340	0.004	0.012	2.784	0.774	0.007	2.553	0.012	0.007	0.4	0.4
136	1350	0.004	0.012	2.796	0.781	0.007	2.565	0.012	0.007	0.4	0.4
137	1360	0.004	0.012	2.807	0.788	0.007	2.576	0.012	0.007	0.4	0.4
138	1370	0.004	0.012	2.819	0.795	0.007	2.588	0.012	0.007	0.4	0.4
139	1380	0.004	0.012	2.830	0.803	0.007	2.599	0.012	0.007	0.4	0.4
140	1390	0.004	0.012	2.842	0.810	0.007	2.611	0.012	0.007	0.4	0.4
141	1400	0.004	0.012	2.854	0.817	0.007	2.623	0.012	0.007	0.4	0.4
142	1410	0.004	0.012	2.865	0.824	0.007	2.634	0.012	0.007	0.4	0.4
143	1420	0.004	0.012	2.877	0.831	0.007	2.646	0.012	0.007	0.4	0.4
144	1430	0.004	0.012	2.888	0.838	0.007	2.657	0.012	0.007	0.4	0.4
145	1440	0.004	0.012	2.900	0.845	0.007	2.669	0.012	0.007	0.4	0.4

Table 2.7
SBUH Values for Developed Site Condition

Given: Area = 10 acres P = 2.9 inches (10-yr., 24-hr. event) dt = 10 minutes
 PERVIOUS AREA: Area = 6.1 acres CN = 89 S = 1.235955 0.2S = 0.25
 IMPERVIOUS AREA: Area = 3.9 acres CN = 98 S = 0.204082 0.2S = 0.04
 Tc = 28 minutes w = 0.151515 where S = potential maximum natural detention (as defined earlier)

Column (1) = Time Increment
 Column (2) = Time (min)
 Column (3) = Type IA Storm Distribution
 Column (4) = Column (3) * P
 Column (5) = Accumulated sum of Column (4)
 Column (6) = If (P < 0.2S) = 0, If (P > 0.2S) = (Column (5) - 0.2S)² / (Column (5) + 0.8S), where the PERVIOUS AREA S value is used
 Column (7) = Column (6) of the present step - Column (6) of the previous step
 Column (8) = Same as Column (6) except use IMPERVIOUS AREA S value
 Column (9) = Column (8) of the present step - Column (8) of the previous step
 Column (10) = (PERVIOUS AREA/TOTAL AREA)*Column (7)+(IMPERVIOUS AREA/TOTAL AREA)*Column (9)
 Column (11) = (60.5*Column (10)*Total Area)/dt, where dt = 10 or 60 minutes
 Column (12) = Column (12) of previous time step + w * [(Column (11) of previous time step + Column (11) of present time step) - (2 * Column (12) of previous time step)] where w = routing constant = dt/(2Tc + dt) = 0.0641

(1) Time Increment	(2) Time (minute)	(3) Rainfall Distrib. (fraction)	(4) Incre. Rainfall (inches)	(5) Accumul. Rainfall (inches)	PERVIOUS		IMPERVIOUS		(10) Total Runoff (inches)	(11) Instant Flowrate (cfs)	(12) Design Flowrate (cfs)
					(6) Accum. Runoff (inches)	(7) Incre. Runoff (inches)	(8) Accum. Runoff (inches)	(9) Incre. Runoff (inches)			
1	0	0	0	0	0	0	0	0	0	0.0	0.0
2	10	0.004	0.012	0.012	0.000	0.000	0.000	0.000	0.000	0.0	0.0
3	20	0.004	0.012	0.023	0.000	0.000	0.000	0.000	0.000	0.0	0.0
4	30	0.004	0.012	0.035	0.000	0.000	0.000	0.000	0.000	0.0	0.0
5	40	0.004	0.012	0.046	0.000	0.000	0.000	0.000	0.000	0.0	0.0
6	50	0.004	0.012	0.058	0.000	0.000	0.001	0.001	0.000	0.0	0.0
7	60	0.004	0.012	0.070	0.000	0.000	0.004	0.002	0.001	0.1	0.0
8	70	0.004	0.012	0.081	0.000	0.000	0.007	0.003	0.001	0.1	0.0
9	80	0.004	0.012	0.093	0.000	0.000	0.011	0.004	0.002	0.1	0.0
10	90	0.004	0.012	0.104	0.000	0.000	0.015	0.005	0.002	0.1	0.1
11	100	0.004	0.012	0.116	0.000	0.000	0.020	0.005	0.002	0.1	0.1
12	110	0.005	0.015	0.131	0.000	0.000	0.027	0.007	0.003	0.2	0.1
13	120	0.005	0.015	0.145	0.000	0.000	0.035	0.008	0.003	0.2	0.1
14	130	0.005	0.015	0.160	0.000	0.000	0.044	0.008	0.003	0.2	0.1
15	140	0.005	0.015	0.174	0.000	0.000	0.053	0.009	0.003	0.2	0.2
16	150	0.005	0.015	0.189	0.000	0.000	0.062	0.009	0.004	0.2	0.2
17	160	0.005	0.015	0.203	0.000	0.000	0.072	0.010	0.004	0.2	0.2
18	170	0.006	0.017	0.220	0.000	0.000	0.084	0.012	0.005	0.3	0.2
19	180	0.006	0.017	0.238	0.000	0.000	0.097	0.013	0.005	0.3	0.2
20	190	0.006	0.017	0.255	0.000	0.000	0.110	0.013	0.005	0.3	0.3
21	200	0.006	0.017	0.273	0.001	0.000	0.123	0.013	0.006	0.3	0.3
22	210	0.006	0.017	0.290	0.001	0.001	0.137	0.014	0.006	0.4	0.3
23	220	0.006	0.017	0.307	0.003	0.001	0.151	0.014	0.006	0.4	0.3
24	230	0.007	0.020	0.328	0.005	0.002	0.168	0.017	0.008	0.5	0.4
25	240	0.007	0.020	0.348	0.008	0.003	0.185	0.017	0.008	0.5	0.4
26	250	0.007	0.020	0.368	0.011	0.003	0.202	0.017	0.009	0.5	0.4
27	260	0.007	0.020	0.389	0.015	0.004	0.219	0.017	0.009	0.5	0.5
28	270	0.007	0.020	0.409	0.019	0.004	0.237	0.018	0.009	0.6	0.5
29	280	0.007	0.020	0.429	0.023	0.005	0.255	0.018	0.010	0.6	0.5
30	290	0.008	0.024	0.453	0.029	0.006	0.276	0.021	0.012	0.7	0.6
31	300	0.008	0.024	0.477	0.036	0.007	0.297	0.021	0.012	0.7	0.6
32	310	0.008	0.024	0.501	0.043	0.007	0.318	0.021	0.013	0.8	0.7
33	320	0.008	0.024	0.524	0.051	0.008	0.340	0.022	0.013	0.8	0.7
34	330	0.008	0.024	0.548	0.059	0.008	0.362	0.022	0.013	0.8	0.7
35	340	0.008	0.024	0.572	0.068	0.009	0.384	0.022	0.014	0.8	0.8
36	350	0.010	0.028	0.599	0.078	0.011	0.409	0.026	0.016	1.0	0.8
37	360	0.010	0.028	0.627	0.089	0.011	0.435	0.026	0.017	1.0	0.9
38	370	0.010	0.028	0.655	0.101	0.012	0.461	0.026	0.017	1.0	0.9

(1)	(2)	(3)	(4)	(5)	(6) PERVIOUS		(8) IMPERVIOUS		(10)	(11)	(12)
Time Increment	Time (minute)	Rainfall Distrib. (fraction)	Incr. Rainfall (inches)	Accumul. Rainfall (inches)	Accum. Runoff (inches)	Incr. Runoff (inches)	Accum. Runoff (inches)	Incr. Runoff (inches)	Total Runoff (inches)	Instant Flowrate (cfs)	Design Flowrate (cfs)
39	380	0.010	0.028	0.682	0.113	0.012	0.486	0.026	0.018	1.1	1.0
40	390	0.010	0.028	0.710	0.126	0.013	0.512	0.026	0.018	1.1	1.0
41	400	0.010	0.028	0.737	0.139	0.013	0.539	0.026	0.018	1.1	1.0
42	410	0.013	0.039	0.776	0.158	0.019	0.575	0.037	0.026	1.6	1.1
43	420	0.013	0.039	0.815	0.179	0.020	0.613	0.037	0.027	1.6	1.3
44	430	0.013	0.039	0.854	0.200	0.021	0.650	0.037	0.027	1.7	1.4
45	440	0.018	0.052	0.906	0.229	0.029	0.700	0.050	0.037	2.3	1.6
46	450	0.018	0.052	0.958	0.260	0.031	0.750	0.050	0.038	2.3	1.8
47	460	0.034	0.099	1.057	0.320	0.061	0.846	0.096	0.074	4.5	2.3
48	470	0.054	0.157	1.213	0.424	0.103	0.999	0.153	0.123	7.4	3.4
49	480	0.027	0.078	1.292	0.478	0.054	1.075	0.077	0.063	3.8	4.1
50	490	0.018	0.052	1.344	0.516	0.037	1.127	0.051	0.043	2.6	3.8
51	500	0.013	0.039	1.383	0.544	0.028	1.165	0.038	0.032	1.9	3.3
52	510	0.013	0.039	1.422	0.572	0.028	1.203	0.038	0.032	2.0	2.9
53	520	0.013	0.039	1.460	0.601	0.029	1.241	0.038	0.032	2.0	2.6
54	530	0.009	0.026	1.486	0.620	0.019	1.266	0.025	0.021	1.3	2.3
55	540	0.009	0.026	1.511	0.639	0.019	1.291	0.025	0.022	1.3	2.0
56	550	0.009	0.026	1.537	0.659	0.019	1.317	0.025	0.022	1.3	1.8
57	560	0.009	0.026	1.563	0.678	0.019	1.342	0.025	0.022	1.3	1.7
58	570	0.009	0.026	1.588	0.698	0.020	1.367	0.025	0.022	1.3	1.5
59	580	0.009	0.026	1.614	0.717	0.020	1.392	0.025	0.022	1.3	1.5
60	590	0.009	0.026	1.639	0.737	0.020	1.417	0.025	0.022	1.3	1.4
61	600	0.009	0.026	1.665	0.757	0.020	1.442	0.025	0.022	1.3	1.4
62	610	0.009	0.026	1.690	0.777	0.020	1.468	0.025	0.022	1.3	1.4
63	620	0.009	0.026	1.716	0.797	0.020	1.493	0.025	0.022	1.3	1.4
64	630	0.009	0.026	1.741	0.818	0.020	1.518	0.025	0.022	1.3	1.4
65	640	0.009	0.026	1.767	0.838	0.020	1.543	0.025	0.022	1.3	1.4
66	650	0.007	0.021	1.788	0.855	0.017	1.564	0.021	0.018	1.1	1.3
67	660	0.007	0.021	1.808	0.871	0.017	1.585	0.021	0.018	1.1	1.3
68	670	0.007	0.021	1.829	0.888	0.017	1.605	0.021	0.018	1.1	1.2
69	680	0.007	0.021	1.850	0.905	0.017	1.626	0.021	0.018	1.1	1.2
70	690	0.007	0.021	1.871	0.922	0.017	1.647	0.021	0.018	1.1	1.2
71	700	0.007	0.021	1.892	0.939	0.017	1.667	0.021	0.018	1.1	1.1
72	710	0.007	0.021	1.913	0.956	0.017	1.688	0.021	0.018	1.1	1.1
73	720	0.007	0.021	1.934	0.973	0.017	1.709	0.021	0.019	1.1	1.1
74	730	0.007	0.021	1.955	0.990	0.017	1.729	0.021	0.019	1.1	1.1
75	740	0.007	0.021	1.975	1.008	0.017	1.750	0.021	0.019	1.1	1.1
76	750	0.007	0.021	1.996	1.025	0.017	1.771	0.021	0.019	1.1	1.1
77	760	0.007	0.021	2.017	1.042	0.017	1.791	0.021	0.019	1.1	1.1
78	770	0.006	0.017	2.034	1.056	0.014	1.808	0.016	0.015	0.9	1.1
79	780	0.006	0.017	2.050	1.070	0.014	1.824	0.016	0.015	0.9	1.0
80	790	0.006	0.017	2.067	1.084	0.014	1.841	0.016	0.015	0.9	1.0
81	800	0.006	0.017	2.083	1.097	0.014	1.857	0.016	0.015	0.9	1.0
82	810	0.006	0.017	2.100	1.111	0.014	1.873	0.016	0.015	0.9	0.9
83	820	0.006	0.017	2.116	1.125	0.014	1.890	0.016	0.015	0.9	0.9
84	830	0.006	0.017	2.133	1.139	0.014	1.906	0.016	0.015	0.9	0.9
85	840	0.006	0.017	2.149	1.153	0.014	1.923	0.016	0.015	0.9	0.9
86	850	0.006	0.017	2.166	1.167	0.014	1.939	0.016	0.015	0.9	0.9
87	860	0.006	0.017	2.183	1.181	0.014	1.955	0.016	0.015	0.9	0.9
88	870	0.006	0.017	2.199	1.195	0.014	1.972	0.016	0.015	0.9	0.9
89	880	0.006	0.017	2.216	1.209	0.014	1.988	0.016	0.015	0.9	0.9
90	890	0.005	0.015	2.230	1.222	0.012	2.003	0.014	0.013	0.8	0.9
91	900	0.005	0.015	2.245	1.234	0.012	2.017	0.014	0.013	0.8	0.9
92	910	0.005	0.015	2.259	1.246	0.012	2.031	0.014	0.013	0.8	0.8
93	920	0.005	0.015	2.274	1.259	0.012	2.046	0.014	0.013	0.8	0.8
94	930	0.005	0.015	2.288	1.271	0.012	2.060	0.014	0.013	0.8	0.8
95	940	0.005	0.015	2.303	1.284	0.012	2.075	0.014	0.013	0.8	0.8

(1)	(2)	(3)	(4)	(5)	(6) PERVIOUS		(8) IMPERVIOUS		(10)	(11)	(12)
Time Increment	Time (minute)	Rainfall Distrib. (fraction)	Incre. Rainfall (inches)	Accumul. Rainfall (inches)	Accum. Runoff (inches)	Incre. Runoff (inches)	Accum. Runoff (inches)	Incre. Runoff (inches)	Total Runoff (inches)	Instant Flowrate (cfs)	Design Flowrate (cfs)
96	950	0.005	0.015	2.317	1.296	0.012	2.089	0.014	0.013	0.8	0.8
97	960	0.005	0.015	2.332	1.309	0.012	2.103	0.014	0.013	0.8	0.8
98	970	0.005	0.015	2.346	1.321	0.012	2.118	0.014	0.013	0.8	0.8
99	980	0.005	0.015	2.361	1.334	0.013	2.132	0.014	0.013	0.8	0.8
100	990	0.005	0.015	2.375	1.346	0.013	2.147	0.014	0.013	0.8	0.8
101	1000	0.005	0.015	2.390	1.359	0.013	2.161	0.014	0.013	0.8	0.8
102	1010	0.004	0.012	2.401	1.369	0.010	2.173	0.012	0.011	0.6	0.8
103	1020	0.004	0.012	2.413	1.379	0.010	2.184	0.012	0.011	0.6	0.7
104	1030	0.004	0.012	2.424	1.389	0.010	2.196	0.012	0.011	0.6	0.7
105	1040	0.004	0.012	2.436	1.399	0.010	2.207	0.012	0.011	0.6	0.7
106	1050	0.004	0.012	2.448	1.409	0.010	2.219	0.012	0.011	0.6	0.7
107	1060	0.004	0.012	2.459	1.419	0.010	2.230	0.012	0.011	0.6	0.7
108	1070	0.004	0.012	2.471	1.429	0.010	2.242	0.012	0.011	0.6	0.7
109	1080	0.004	0.012	2.482	1.439	0.010	2.253	0.012	0.011	0.6	0.7
110	1090	0.004	0.012	2.494	1.449	0.010	2.265	0.012	0.011	0.6	0.7
111	1100	0.004	0.012	2.506	1.460	0.010	2.276	0.012	0.011	0.6	0.7
112	1110	0.004	0.012	2.517	1.470	0.010	2.288	0.012	0.011	0.6	0.6
113	1120	0.004	0.012	2.529	1.480	0.010	2.299	0.012	0.011	0.6	0.6
114	1130	0.004	0.012	2.540	1.490	0.010	2.311	0.012	0.011	0.6	0.6
115	1140	0.004	0.012	2.552	1.500	0.010	2.322	0.012	0.011	0.6	0.6
116	1150	0.004	0.012	2.564	1.510	0.010	2.334	0.012	0.011	0.6	0.6
117	1160	0.004	0.012	2.575	1.521	0.010	2.346	0.012	0.011	0.6	0.6
118	1170	0.004	0.012	2.587	1.531	0.010	2.357	0.012	0.011	0.6	0.6
119	1180	0.004	0.012	2.598	1.541	0.010	2.369	0.012	0.011	0.6	0.6
120	1190	0.004	0.012	2.610	1.551	0.010	2.380	0.012	0.011	0.6	0.6
121	1200	0.004	0.012	2.622	1.562	0.010	2.392	0.012	0.011	0.6	0.6
122	1210	0.004	0.012	2.633	1.572	0.010	2.403	0.012	0.011	0.7	0.6
123	1220	0.004	0.012	2.645	1.582	0.010	2.415	0.012	0.011	0.7	0.6
124	1230	0.004	0.012	2.656	1.592	0.010	2.426	0.012	0.011	0.7	0.7
125	1240	0.004	0.012	2.668	1.603	0.010	2.438	0.012	0.011	0.7	0.7
126	1250	0.004	0.012	2.680	1.613	0.010	2.449	0.012	0.011	0.7	0.7
127	1260	0.004	0.012	2.691	1.623	0.010	2.461	0.012	0.011	0.7	0.7
128	1270	0.004	0.012	2.703	1.633	0.010	2.472	0.012	0.011	0.7	0.7
129	1280	0.004	0.012	2.714	1.644	0.010	2.484	0.012	0.011	0.7	0.7
130	1290	0.004	0.012	2.726	1.654	0.010	2.496	0.012	0.011	0.7	0.7
131	1300	0.004	0.012	2.738	1.664	0.010	2.507	0.012	0.011	0.7	0.7
132	1310	0.004	0.012	2.749	1.675	0.010	2.519	0.012	0.011	0.7	0.7
133	1320	0.004	0.012	2.761	1.685	0.010	2.530	0.012	0.011	0.7	0.7
134	1330	0.004	0.012	2.772	1.695	0.010	2.542	0.012	0.011	0.7	0.7
135	1340	0.004	0.012	2.784	1.706	0.010	2.553	0.012	0.011	0.7	0.7
136	1350	0.004	0.012	2.796	1.716	0.010	2.565	0.012	0.011	0.7	0.7
137	1360	0.004	0.012	2.807	1.726	0.010	2.576	0.012	0.011	0.7	0.7
138	1370	0.004	0.012	2.819	1.737	0.010	2.588	0.012	0.011	0.7	0.7
139	1380	0.004	0.012	2.830	1.747	0.010	2.599	0.012	0.011	0.7	0.7
140	1390	0.004	0.012	2.842	1.758	0.010	2.611	0.012	0.011	0.7	0.7
141	1400	0.004	0.012	2.854	1.768	0.010	2.623	0.012	0.011	0.7	0.7
142	1410	0.004	0.012	2.865	1.778	0.010	2.634	0.012	0.011	0.7	0.7
143	1420	0.004	0.012	2.877	1.789	0.010	2.646	0.012	0.011	0.7	0.7
144	1430	0.004	0.012	2.888	1.799	0.010	2.657	0.012	0.011	0.7	0.7
145	1440	0.004	0.012	2.900	1.810	0.010	2.669	0.012	0.011	0.7	0.7

2.3.4 Hydrograph Routing (Sizing Detention Facilities)

A methodology is presented here for routing a hydrograph through an existing retention/detention facility or closed depression, and for sizing a new retention/detention facility using hydrograph analysis.

Storage Routing Technique: The “level pool routing” technique presented here is one of the simplest and most commonly used hydrograph routing methods. This method is described in “Handbook of Applied Hydrology,” Chow, V. Te, 1964, and elsewhere, and is based on the continuity equation:

Inflow - Outflow = Change in Storage

$$\left[\frac{I_1 + I_2}{2} - \frac{O_1 + O_2}{2} \right] = \frac{\Delta S}{\Delta t} = \frac{S_2 - S_1}{\Delta t}$$

Where I = Inflow at time 1 and time 2

O = Outflow at time 1 and time 2

S = Storage at time 1 and time 2

Δt = Time interval, 2-1

The time interval, Δt , must be consistent with the time interval used in developing the inflow hydrograph. The time interval used for a 24-hour storm is 10 minutes while the time interval used for a 7-day storm is 60 minutes. The Δt variable can be eliminated by dividing it into the storage variables to obtain the following rearranged equation:

$$I_1 + I_2 + 2S_1 - O_1 = O_2 + 2S_2$$

If the time interval, Δt , is in minutes and the units of storage (S) are in cubic feet (cf), this can be converted to cubic feet per second (cfs) by dividing by 60.

The terms I_1 , I_2 , O_1 , and S_1 are known from the inflow hydrograph and from the storage and outflow values of the previous time step. The unknowns O_2 and S_2 can be solved interactively from the given stage-storage and stage-discharge curves.

Appendix D –

NRCS Table of Curve Numbers

Time of Concentration Calculation

Figure 2-3 Composite CN with connected impervious area.

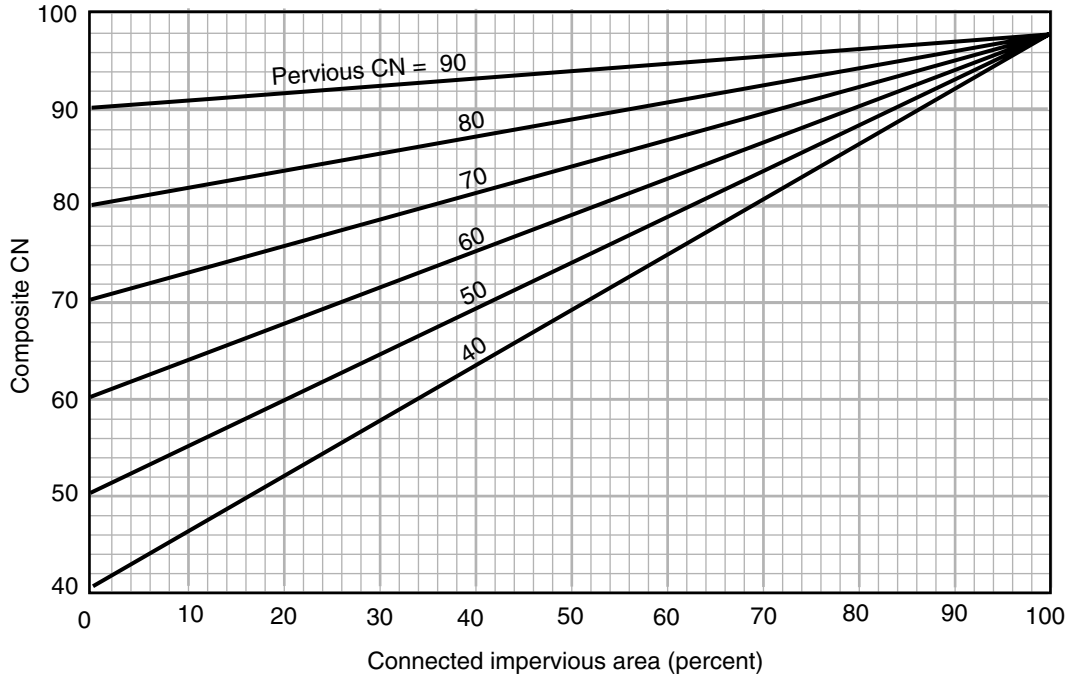

Figure 2-4 Composite CN with unconnected impervious areas and total impervious area less than 30%.

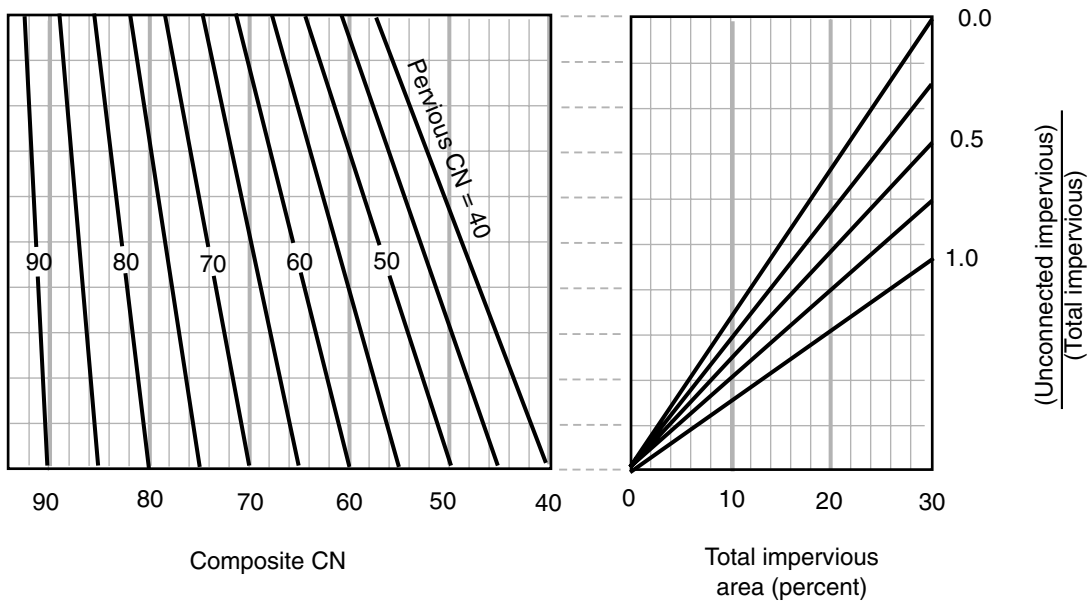

Table 2-2a Runoff curve numbers for urban areas ^{1/}

Cover description	Average percent impervious area ^{2/}	Curve numbers for hydrologic soil group			
		A	B	C	D
Fully developed urban areas (vegetation established)					
Open space (lawns, parks, golf courses, cemeteries, etc.) ^{3/} :					
Poor condition (grass cover < 50%)		68	79	86	89
Fair condition (grass cover 50% to 75%)		49	69	79	84
Good condition (grass cover > 75%)		39	61	74	80
Impervious areas:					
Paved parking lots, roofs, driveways, etc. (excluding right-of-way)		98	98	98	98
Streets and roads:					
Paved; curbs and storm sewers (excluding right-of-way)		98	98	98	98
Paved; open ditches (including right-of-way)		83	89	92	93
Gravel (including right-of-way)		76	85	89	91
Dirt (including right-of-way)		72	82	87	89
Western desert urban areas:					
Natural desert landscaping (pervious areas only) ^{4/}		63	77	85	88
Artificial desert landscaping (impervious weed barrier, desert shrub with 1- to 2-inch sand or gravel mulch and basin borders)		96	96	96	96
Urban districts:					
Commercial and business	85	89	92	94	95
Industrial	72	81	88	91	93
Residential districts by average lot size:					
1/8 acre or less (town houses)	65	77	85	90	92
1/4 acre	38	61	75	83	87
1/3 acre	30	57	72	81	86
1/2 acre	25	54	70	80	85
1 acre	20	51	68	79	84
2 acres	12	46	65	77	82

Developing urban areas

Newly graded areas
(pervious areas only, no vegetation) ^{5/}

	77	86	91	94
--	----	----	----	----

Idle lands (CN's are determined using cover types
similar to those in table 2-2c).

^{1/} Average runoff condition, and $I_a = 0.2S$.

^{2/} The average percent impervious area shown was used to develop the composite CN's. Other assumptions are as follows: impervious areas are directly connected to the drainage system, impervious areas have a CN of 98, and pervious areas are considered equivalent to open space in good hydrologic condition. CN's for other combinations of conditions may be computed using figure 2-3 or 2-4.

^{3/} CN's shown are equivalent to those of pasture. Composite CN's may be computed for other combinations of open space cover type.

^{4/} Composite CN's for natural desert landscaping should be computed using figures 2-3 or 2-4 based on the impervious area percentage (CN = 98) and the pervious area CN. The pervious area CN's are assumed equivalent to desert shrub in poor hydrologic condition.

^{5/} Composite CN's to use for the design of temporary measures during grading and construction should be computed using figure 2-3 or 2-4 based on the degree of development (impervious area percentage) and the CN's for the newly graded pervious areas.

Table 2-2b Runoff curve numbers for cultivated agricultural lands ^{1/}

Cover description			Curve numbers for hydrologic soil group			
Cover type	Treatment ^{2/}	Hydrologic condition ^{3/}	A	B	C	D
Fallow	Bare soil	—	77	86	91	94
	Crop residue cover (CR)	Poor	76	85	90	93
		Good	74	83	88	90
Row crops	Straight row (SR)	Poor	72	81	88	91
		Good	67	78	85	89
	SR + CR	Poor	71	80	87	90
		Good	64	75	82	85
	Contoured (C)	Poor	70	79	84	88
		Good	65	75	82	86
	C + CR	Poor	69	78	83	87
		Good	64	74	81	85
	Contoured & terraced (C&T)	Poor	66	74	80	82
		Good	62	71	78	81
C&T+ CR	Poor	65	73	79	81	
	Good	61	70	77	80	
Small grain	SR	Poor	65	76	84	88
		Good	63	75	83	87
	SR + CR	Poor	64	75	83	86
		Good	60	72	80	84
	C	Poor	63	74	82	85
		Good	61	73	81	84
	C + CR	Poor	62	73	81	84
		Good	60	72	80	83
	C&T	Poor	61	72	79	82
		Good	59	70	78	81
C&T+ CR	Poor	60	71	78	81	
	Good	58	69	77	80	
Close-seeded or broadcast legumes or rotation meadow	SR	Poor	66	77	85	89
		Good	58	72	81	85
	C	Poor	64	75	83	85
		Good	55	69	78	83
	C&T	Poor	63	73	80	83
		Good	51	67	76	80

¹ Average runoff condition, and $I_a=0.2S$

² Crop residue cover applies only if residue is on at least 5% of the surface throughout the year.

³ Hydraulic condition is based on combination factors that affect infiltration and runoff, including (a) density and canopy of vegetative areas, (b) amount of year-round cover, (c) amount of grass or close-seeded legumes, (d) percent of residue cover on the land surface (good $\geq 20\%$), and (e) degree of surface roughness.

Poor: Factors impair infiltration and tend to increase runoff.

Good: Factors encourage average and better than average infiltration and tend to decrease runoff.

Table 2-2c Runoff curve numbers for other agricultural lands ^{1/}

Cover description	Hydrologic condition	Curve numbers for hydrologic soil group			
		A	B	C	D
Pasture, grassland, or range—continuous forage for grazing. ^{2/}	Poor	68	79	86	89
	Fair	49	69	79	84
	Good	39	61	74	80
Meadow—continuous grass, protected from grazing and generally mowed for hay.	—	30	58	71	78
Brush—brush-weed-grass mixture with brush the major element. ^{3/}	Poor	48	67	77	83
	Fair	35	56	70	77
	Good	30 ^{4/}	48	65	73
Woods—grass combination (orchard or tree farm). ^{5/}	Poor	57	73	82	86
	Fair	43	65	76	82
	Good	32	58	72	79
Woods. ^{6/}	Poor	45	66	77	83
	Fair	36	60	73	79
	Good	30 ^{4/}	55	70	77
Farmsteads—buildings, lanes, driveways, and surrounding lots.	—	59	74	82	86

¹ Average runoff condition, and $I_a = 0.2S$.

² **Poor:** <50% ground cover or heavily grazed with no mulch.

Fair: 50 to 75% ground cover and not heavily grazed.

Good: > 75% ground cover and lightly or only occasionally grazed.

³ **Poor:** <50% ground cover.

Fair: 50 to 75% ground cover.

Good: >75% ground cover.

⁴ Actual curve number is less than 30; use CN = 30 for runoff computations.

⁵ CN's shown were computed for areas with 50% woods and 50% grass (pasture) cover. Other combinations of conditions may be computed from the CN's for woods and pasture.

⁶ **Poor:** Forest litter, small trees, and brush are destroyed by heavy grazing or regular burning.

Fair: Woods are grazed but not burned, and some forest litter covers the soil.

Good: Woods are protected from grazing, and litter and brush adequately cover the soil.

Table 2-2d Runoff curve numbers for arid and semiarid rangelands ^{1/}

Cover description		Curve numbers for hydrologic soil group			
Cover type	Hydrologic condition ^{2/}	A ^{3/}	B	C	D
Herbaceous—mixture of grass, weeds, and low-growing brush, with brush the minor element.	Poor		80	87	93
	Fair		71	81	89
	Good		62	74	85
Oak-aspen—mountain brush mixture of oak brush, aspen, mountain mahogany, bitter brush, maple, and other brush.	Poor		66	74	79
	Fair		48	57	63
	Good		30	41	48
Pinyon-juniper—pinyon, juniper, or both; grass understory.	Poor		75	85	89
	Fair		58	73	80
	Good		41	61	71
Sagebrush with grass understory.	Poor		67	80	85
	Fair		51	63	70
	Good		35	47	55
Desert shrub—major plants include saltbush, greasewood, creosotebush, blackbrush, bursage, palo verde, mesquite, and cactus.	Poor	63	77	85	88
	Fair	55	72	81	86
	Good	49	68	79	84

¹ Average runoff condition, and I_a , = 0.2S. For range in humid regions, use table 2-2c.

² Poor: <30% ground cover (litter, grass, and brush overstory).

Fair: 30 to 70% ground cover.

Good: > 70% ground cover.

³ Curve numbers for group A have been developed only for desert shrub.

Worksheet 2: Runoff curve number and runoff

Project	By	Date
Location	Checked	Date

Check one: Present Developed

1. Runoff curve number

Soil name and hydrologic group <small>(appendix A)</small>	Cover description <small>(cover type, treatment, and hydrologic condition; percent impervious; unconnected/connected impervious area ratio)</small>	CN ^{1/}			Area <input type="checkbox"/> acres <input type="checkbox"/> mi ² <input type="checkbox"/> %	Product of CN x area
		Table 2-2	Figure 2-3	Figure 2-4		

^{1/} Use only one CN source per line

Totals ➡

CN (weighted) = $\frac{\text{total product}}{\text{total area}}$ = _____ = _____ ;

Use CN ➡

2. Runoff

	Storm #1	Storm #2	Storm #3
Frequency yr			
Rainfall, P (24-hour) in			
Runoff, Q in			

(Use P and CN with table 2-1, figure 2-1, or equations 2-3 and 2-4)

TR 55 Worksheet 3: Time of Concentration (T_c) or Travel Time (T_t)

Project: _____ Designed By: _____ Date: _____

Location: _____ Checked By: _____ Date: _____

Circle one: Present Developed

Circle one: T_c T_t through subarea _____

NOTES: Space for as many as two segments per flow type can be used for each worksheet. Include a map, schematic, or description of flow segments.

Sheet Flow (Applicable to T_c only)

Segment ID

1. Surface description (Table 3-1)
2. Manning's roughness coeff., n (Table 3-1)
3. Flow length, L (total L ≤ 100 ft) ft
4. Two-year 24-hour rainfall, P₂..... in
5. Land slope, s ft/ft
6. $T_t = \frac{0.007 (nL)^{0.8}}{P_2^{0.5} s^{0.4}}$ Compute T_t hr

+	=

Shallow Concentrated Flow

Segment ID

7. Surface description (paved or unpaved)
8. Flow length, L ft
9. Watercourse slope, s ft/ft
10. Average velocity, V (Figure 3-1) ft/s
11. $T_t = \frac{L}{3600 V}$ Compute T_t hr

+	=

Channel Flow

Segment ID

12. Cross sectional flow area, a ft²
13. Wetted perimeter, P_w ft
14. Hydraulic radius, $r = \frac{a}{P_w}$ Compute r ft
15. Channel Slope, s ft/ft
16. Manning's Roughness Coeff., n
17. $V = \frac{1.49 r^{2/3} s^{1/2}}{n}$ Compute V ft/s
18. Flow length, L ft
19. $T_t = \frac{L}{3600 V}$ Compute T_t hr
20. Watershed or subarea T_c or T_t (add T_t in steps 6, 11, and 19) hr

+	=
+	=

Appendix E - Plant Specifications

TABLE OF CONTENTS

Criteria for Choosing Plants.....	E-1
Recommendations for Stormwater Management.....	E-1
Soil Depth Influences Plant Choice.....	E-1
Plant Spacing, Density & Container Size.....	E-2
Safety & Crime.....	E-3
Choosing Plants from Plant Lists Generated Using USDA PLANTS Database.....	E-3
Planting Techniques.....	E-10
Planting in Containers.....	E-11
Planting in the Ground.....	E-11
Establishment Period Maintenance.....	E-11
Irrigation.....	E-11
Integrated Pest Management.....	E-12
Sourcing Plants.....	E-13
References.....	E-13

Appendix E - Plant Specifications

CRITERIA FOR CHOOSING PLANTS

Above all, plants should be chosen using the motto “Right Plant, Right Place”. Plants in BMPs provide many ecological, hydraulic, and social functions, which must be considered. When choosing the best plants as stormwater managers, first consider water quality function of the facility. A diverse assembly of long-lived plants should be chosen according to the guidance provided throughout this appendix. Varying heights and rooting depths are also beneficial, if feasible.

Recommendations for Stormwater Management

Natives, non-natives, and invasives are not interchangeable terms. Their differences and the reasons for the following recommendations are provided below.

Suitable Plants Hierarchy. When choosing suitable plants, use the following hierarchy:

- Due to the availability of a variety of suitable species at nurseries (NPSO [a]), we recommend using native plants (groundcover, forbs (flowers), shrubs, and trees) wherever possible. In the case of street trees, if soils are highly degraded, avoid native trees.
- Use non-native plants only with the following research:
 - Avoid plants that reproduce readily. These are plants that spread by seeds (*e.g.* grasses), rhizomes (when a piece of broken off root will start a new plant, *e.g.* Yellow flag iris), or culms (when a piece of a stem is able to re-root, *e.g.* English Ivy), etc.
 - Avoid plants listed for “Exotic Gardening and Landscaping Plants” on the Native Plant Society’s Emerald Chapter website (NPSO [b]) that are emerging as problematic. Avoid plants listed on the invasive plant lists of Washington (Washington State NWCB) and California (ISCC).
- Avoid invasive plants listed on the Oregon Department of Agriculture “Oregon Noxious Weed List” (Oregon Department of Agriculture, 2016).
- A list of native plant and seed suppliers in Oregon is available on Rogue Valley Sewer Services website under [Appendix E](#).

Soil Depth Influences Plant Choice

Generally, the more soil, the better it will be for the plant. Choose plants that, at maturity, will still have enough soil to be low maintenance. Too little soil can stunt the size of the plant or, in the case of trees, cause it to be unhealthy and drop limbs. For plants to reach their full size at maturity and be low maintenance, soil depth requirements vary with the plant type. Generally, soil depth minimums are as follows:

- Sedums: 2”
- Grasses: 12”. Generally, the roots of grasses and grass-like plants will be as deep as the plant is tall so some species may benefit from deeper soil.
- Shrubs: 18”, but 24” is preferable.
- Trees: 36”, but depending on the species, trees also need a minimum volume of soil, 400 to 1,000 cubic feet. Since tree roots often don’t extend much deeper than 3 feet, the minimum area needed is 133 to 333 square feet (see Chapter 3 of the LID Guide “Tree Planting BMP”).

Lined Vegetated Stormwater Facilities. Trees are not suitable for lined facilities unless additional cost is incurred to incorporate adequate soil depths.

Appendix E - Plant Specifications

PLANT SPACING, DENSITY & CONTAINER SIZE

Applicability. The information in this section applies to the following BMPs:

- Restored Soils BMP
- Vegetated Roofs (Green Roofs) BMP
- Rain Garden BMP
- Stormwater Planter BMP
- LID Swale BMP
- Water Quality Conveyance Swale BMP
- Vegetated Filter Strip BMP

The BMPs above rely on good vegetative cover to optimize water quality treatment and reduce maintenance needs, such as weeding.

Plant spacing and pot size needed to achieve the coverage goals -- provided in the detailed guidance for each BMP in Chapter 4 – vary based on the type of plant, as follows. This section does not apply to street tree planting.

Suggested Plant Tables for Combining Plant Types. Plant densities that exceed the following tables may be desired for initial aesthetic reasons. For a cost- and environmentally-effective facility, minimum required plant quantities are as follows:

Table E-1. Plant numbers and spacing requirements for a vegetation mix consisting primarily of herbaceous plants and small shrubs.

Number of plants	Vegetation type	Per square feet of BMP	Size	Spacing density (average on center)*
66	Herbaceous plants	100	plugs or larger	1.5'
OR				
58	Herbaceous plants	100	plugs or larger	1.5'
4	Small shrubs	100	1 gallon	3' to 4'**
OR				
100% Native low-mow or no-mow seed coverage (follow supplier guidelines for density)				

* An average on-center density is provided as general guidance. However to prevent short circuiting, plants must be randomly placed throughout per Standard Drawings BMP 1.04, 2.05, 3.03.

** Depending on mature spread. Shrubs may be placed farther away than the density indicated but not closer.

Appendix E - Plant Specifications

Table E-2. Plant numbers and spacing requirements for a mix of herbaceous plants, small and large shrubs.

Number of plants	Vegetation type	Per square feet of BMP	Size	Spacing density (average on center)*
58	Herbaceous plants	100	plugs or larger	1.5'
4	Large shrubs	100	1 gallon	4' to 8'**
OR				
6	Medium to small shrubs	100	1 gallon	3' to 8'***
35	Small shrubs	100	1 gallon	3' to 4'***

* To reduce erosion, plants should be randomly located. The average on-center density is provided as general guidance.

** Depending on mature spread. Shrubs may be placed farther away than density indicated but not closer.

Table E-3. Trees may be added to any of the above planting configurations, if appropriate. The recommended minimum density for trees is as follows.

Number of plants	Vegetation type	Per square feet of BMP	Size
1	Evergreen tree	300	6' minimum height
OR			
1	Deciduous tree	300	1.5" minimum diameter*

* Measured at a height 6 inches above the base.

SAFETY & CRIME

Regardless of the land use, vegetation should not block ground floor views either to or from a property (sometimes referred to as “eyes on the street”) or provide hiding places for unauthorized users. Shrubs that grow excessively dense and/or tall should be planted with care. Some questions to ask about chosen plants when they reach their mature height and spread are as follows.

Will this plant (or associated landscape elements such as rocks, benches, etc):

- Obstruct traffic or block road signs? Check for setbacks and height limitations in rights of ways.
- Create a hazard? Does the plant have weak branches or does it tend to create excessively slippery or otherwise hazardous debris?
- Block views of ground floor windows or doors?
- Provide a place for unauthorized users to hide?
- Provide unauthorized access to a roof?
- Redirect foot traffic away from access points with the use of short, impenetrable hedges or thorny shrubs?

CHOOSING PLANTS FROM PLANT LISTS GENERATED USING USDA PLANTS DATABASE

Moisture is considered one of the most important factors in choosing successful plants for your BMPs. Consider the drying effects of sunlight and wind when determining the moisture available at your site. As a result of buildings and other shading infrastructure, even very small sites may have a combination of light and moisture

Appendix E - Plant Specifications

availability.

The USDA has online guidance for finding plants native to your state and even your county. As the search is more and more narrowed, fewer plants will be on the final list. Where you need more detailed guidance, a qualified landscape architect, landscape designer, or horticulturist can assist with narrowing the palette for your region.

Table E-4. The following tutorial with screen shots should help you use their website to identify suitable plants for your project. You may want to visit a nearby native plant nursery to check plant availability. If no native plant nursery is nearby, native plants are still likely to be available in your region, but cross-reference what’s available in your area with this database.

Tutorial Directions & Related Information:	What To Look For OR What You’ll See:
Generate a List of Native Plants in Your County:	
<p>1. Go online to the USDA PLANTS Database at: plants.usda.gov</p>	
<p>2. In the upper left hand corner click on “Advanced Search”.</p>	<p>I. Distribution</p> <p>PLANTS include: Any PLANTS Floristic Area or Not --North America --Lower 48 U.S. States --Alaska --Canada</p> <p><small>Note: PLANTS Floristic Area or Not cannot be used with the next two search boxes.</small></p> <p>State and Province include: Any U.S. States --Alabama --Alaska --Arizona --Arkansas</p> <p><small>Note: County results are added to State and Province results. See About the Advanced Search and Download for details.</small></p> <p>County Distribution (Select a maximum of 256) include: Oregon: Clatsop Oregon: Columbia Oregon: Coos Oregon: Crook Oregon: Curry Oregon: Deschutes</p>
<p>3. We’re going to pick and choose a few different items on the “Advanced Search and Download” web page. Not all search options need attention. For any of these scroll menus, you may have to click outside the box in white space to get your choice to “stick”.</p> <p>Start by scrolling down under “Part A: PLANTS Core Data” to “1. Distribution” to “County Distribution” and choose your county. For this example, we’ll use Coos County.</p>	

Appendix E - Plant Specifications

<p>4. Scroll down under “Part A: PLANTS Core Data” to “2. Taxonomy” to “National Common Name” and click the checkbox to the right that says “Display”</p>	<p>National Common Name include: <input type="text"/> <input checked="" type="checkbox"/> Display Wild cards are permitted.</p>																				
<p>5. Scroll down under “Part A: PLANTS Core Data” to “3. Ecology” to “Duration” and choose “Perennial”</p>	<p>3. Ecology Duration include: <input type="text" value="Any"/> Annual Biennial Perennial</p>																				
<p>6. Scroll down to the next item under “Part A: PLANTS Core Data” to “3. Ecology” to “Native Status” and choose “--L48 Native”</p>	<p>3. Ecology Duration include: <input type="text" value="Any"/> Annual Biennial Perennial Growth Habit include: <input type="text" value="Any"/> Forb/herb Graminoid Lichenous Native Status include: <input type="text" value="Any"/> Native to PLANTS Floristic Area --North America Native --L48 Native --AK Native --CAN Native</p>																				
<p>7. A list (partially shown here) is generated of all perennial plants native to your county with their common names. To the right is the beginning of the list for Coos County.</p>	<table border="0"> <thead> <tr> <th>Scientific Name</th> <th>Common Name</th> </tr> </thead> <tbody> <tr> <td><i>Abies grandis</i></td> <td>grand fir</td> </tr> <tr> <td><i>Abronia latifolia</i></td> <td>coastal sand verbena</td> </tr> <tr> <td><i>Abronia umbellata</i></td> <td>pink sand verbena</td> </tr> <tr> <td><i>Abronia umbellata ssp. breviflora</i></td> <td>pink sand verbena</td> </tr> <tr> <td><i>Acer circinatum</i></td> <td>vine maple</td> </tr> <tr> <td><i>Acer glabrum</i></td> <td>Rocky Mountain maple</td> </tr> <tr> <td><i>Acer macrophyllum</i></td> <td>bigleaf maple</td> </tr> <tr> <td><i>Achillea millefolium</i></td> <td>common yarrow</td> </tr> <tr> <td><i>Achillea millefolium var. littoralis</i></td> <td>coast yarrow</td> </tr> </tbody> </table>	Scientific Name	Common Name	<i>Abies grandis</i>	grand fir	<i>Abronia latifolia</i>	coastal sand verbena	<i>Abronia umbellata</i>	pink sand verbena	<i>Abronia umbellata ssp. breviflora</i>	pink sand verbena	<i>Acer circinatum</i>	vine maple	<i>Acer glabrum</i>	Rocky Mountain maple	<i>Acer macrophyllum</i>	bigleaf maple	<i>Achillea millefolium</i>	common yarrow	<i>Achillea millefolium var. littoralis</i>	coast yarrow
Scientific Name	Common Name																				
<i>Abies grandis</i>	grand fir																				
<i>Abronia latifolia</i>	coastal sand verbena																				
<i>Abronia umbellata</i>	pink sand verbena																				
<i>Abronia umbellata ssp. breviflora</i>	pink sand verbena																				
<i>Acer circinatum</i>	vine maple																				
<i>Acer glabrum</i>	Rocky Mountain maple																				
<i>Acer macrophyllum</i>	bigleaf maple																				
<i>Achillea millefolium</i>	common yarrow																				
<i>Achillea millefolium var. littoralis</i>	coast yarrow																				
<p>Displaying Additional Information</p>																					
<p>7. Instead of narrowing the list, you can also choose to display information about a particular plant.</p> <p>Scroll down to the next item under “Part B: Characteristics Data” to “2. Growth Requirements” and click the display button next to “Adapted to Coarse Textured Soils”, “Adapted to Medium Textured Soils”, and “Adapted to Fine Textured Soils”. Soil texture is an important consideration for choosing plants when a BMP will have native or</p>	<p>2. Growth Requirements</p> <p>Adapted to Coarse Textured Soils include: <input type="text" value="Any"/> Yes No <input checked="" type="checkbox"/> Display</p> <p>Adapted to Medium Textured Soils include: <input type="text" value="Any"/> Yes No <input checked="" type="checkbox"/> Display</p> <p>Adapted to Fine Textured Soils include: <input type="text" value="Any"/> Yes No <input checked="" type="checkbox"/> Display</p>																				

Appendix E - Plant Specifications

amended planting soil.

According to the PLANTS database website, coarse, medium, and fine soils correspond to the USDA soil texture classes as follows:

Characteristics soil texture groups and corresponding soil texture classes.

Characteristics soil texture group	Corresponding soil texture classes from the Soil Texture Triangle		
Coarse	Sand	Coarse sand	Fine sand
	Loamy coarse sand	Loamy fine sand	Loamy very fine sand
	Very fine sand	Loamy sand	
Medium	Silt	Sandy clay loam	Very fine sandy loam
	Silty clay loam	Silt loam	Loam
	Fine sandy loam	Sandy loam	Coarse sandy loam
	Clay loam		
Fine	Sandy clay	Silty clay	Clay

Source: The soil texture classes are from the Soil Science Society of America, <http://www.soils.org/>. An NRCS team partitioned the soil textures into the three groups.

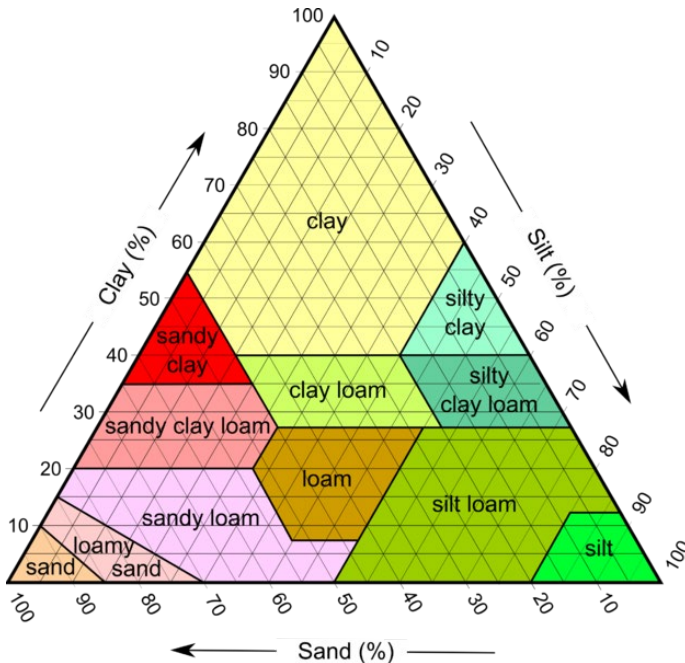

Courtesy of wikimedia user: Mikenorton. Adapted from the USDA.

For a rough field estimate of texture, see Ribbon Testing in Appendix B.

8. Scroll down (or up) to the “Display Results” button and click on it.

Display Results

Review Selections or Sort Report

Display Results runs the entire search, Parts A and B

Appendix E - Plant Specifications

9. A list (partially shown here) is generated of all perennial plants native to your county with their common names including the criteria (when data exists) requested by clicking the display button.

Additional data (when it exists) under “Part B: Characteristics Data” that you may want to know about when choosing plants includes:

- * “Active Growth Period”
- * C:N Ratio (Carbon to Nitrogen Ratio)
- * Fire Resistant
- * Height at Base Age (Base age is 20 years for our region. This info is equivalent to the mature height.)
- * Nitrogen fixation
- * Drought tolerance
- * pH, minimum
- * pH, maximum
- * Precipitation, minimum
- * Precipitation, maximum
- * Shade tolerance
- * Vegetative Spread Rate
- * Many other choices on aesthetics

Click the display check box to see the data of interest.

Scientific Name	Active Growth Period	Adapted to Coarse Textured Soils	Adapted to Medium Textured Soils	Adapted to Fine Textured Soils
<i>Abronia latifolia</i>				
<i>Abronia umbellata</i>				
<i>Abronia umbellata ssp. breviflora</i>				
<i>Achillea millefolium</i>	Spring	No	Yes	No
<i>Achillea millefolium var. littoralis</i>				
<i>Achlys triphylla</i>				
<i>Actaea rubra</i>				
<i>Actaea rubra ssp. arauta</i>				

Narrow the Search for a Particular Plant Type:

10. To narrow the search to certain types of plant click on the “Back” button or back arrow of your internet browser. Selections that might be appropriate to plant in the BMPs presented here are:

- Forb/herb (flowering plants that aren’t grasses, sedges, & rushes)
- Graminoid (grasses, sedges, & rushes)
- Shrub
- Subshrub
- Tree
- Vine



11. Scroll down to “3. Ecology” and “Growth Habit”. For this example, choose “Forb/herb”. (To choose more than one selection at a time in any of these lists, hold down the “Ctrl” button on your computer while scrolling and clicking. Once you’re done selecting, you can double check your selections by letting go of the Ctrl button and scrolling around to see if more than one selection is highlighted.)

3. Ecology

Duration include: Any, Annual, Biennial, Perennial

Growth Habit include: Any, Forb/herb, Graminoid, Lichenous

Native Status include: Any, Native to PLANTS Floristic Area, --North America Native, --L48 Native, --AK Native, --CAN Native

12. Your previous choices should still be selected. Scroll to “Review Selections or Sort Report” button in the middle or bottom of the page and click this to see what criteria you’ve entered so far.

Display Results **Review Selections or Sort Report**

Display Results runs the entire search, Parts A and B

13. After you click, you’ll see all your criteria listed.

Review Selections or Sort Report

Search and display criteria are listed below. Review your selections, and choose optional sort options if you plan to Display Report. Or, Modify Selections to change your criteria.

Items Selected for Part A: PLANTS Core Data

1. Distribution
 County include: Oregon:Coos

2. Taxonomy
 Scientific Name include: Accepted Names and Synonyms Display in Report

3. Ecology
 Duration include: Perennial
 Growth Habit include: Forb/herb
 Native Status include: L48 Native

14. Now click the “Display Results” button at the bottom of this page.

Display Results **Review Selections or Sort Report**

Display Results runs the entire search, Parts A and B

15. A new list (partially shown) is now

narrowed to native, perennial forbs (flowers) in Coos County.	Scientific Name	Active Growth Period	Adapted to Coarse Textured Soils	Adapted to Medium Textured Soils	Adapted to Fine Textured Soils
	<i>Abronia latifolia</i>				
	<i>Abronia umbellata</i>				
	<i>Abronia umbellata</i> ssp. <i>breviflora</i>				
	<i>Achillea millefolium</i>	Spring	No	Yes	No
	<i>Achillea millefolium</i> var. <i>litoralis</i>				
	<i>Achlys triphylla</i>				
<i>Actaea rubra</i>					

Finding Plants for Moisture Zones in BMPs

16. Moisture zones vary with grades and the location of inlets and outlets in rain gardens, stormwater planters, and swales. The different moisture zones (base, slope, top) can be correlated to National Wetland Indicator Status (Emmanuel, 2010) as indicated in Figure E-2 below.

To narrow your search to find plants appropriate for moderate moisture zones (per Figure E-2 below), scroll down to the next item under “Part A: PLANTS Core Data” to “4. Legal Status” and look for “National Wetland Indicator Status”. Choose FAC+

(For zones with more than one possible wetland status indicator, hold down the “Ctrl” button on your keyboard, click on FAC+, FACW, FAC, and/or FAC-. (At the time of this publication, simply clicking on the display button did not display any information, even though most plants have a wetland status assigned.)

National Wetland Indicator Status include: --FACW? (Possibly Facultative Wetland)
 --FACW- (Facultative Wetland-)
 --FACW-? (Possibly Facultative Wetland-)
 --FAC+ (Facultative+)

17. Click on the “Display Results” button at the bottom of this page.

Display Results **Modify Selections**

Display Results runs the entire search, Parts A and B

18. You’ll see all the flowering, perennial plants native to Coos County, OR that are appropriate for the moist zones of a rain garden, stormwater planter or swale (as indicated in Figure E-2 below)

TOPOGRAPHIC ZONES CREATED
BY GRADING PLAN

MOISTURE ZONES CREATED BY
GRADING PLAN AND
INLET & OUTLET LOCATIONS

STORMWATER PLANTERS

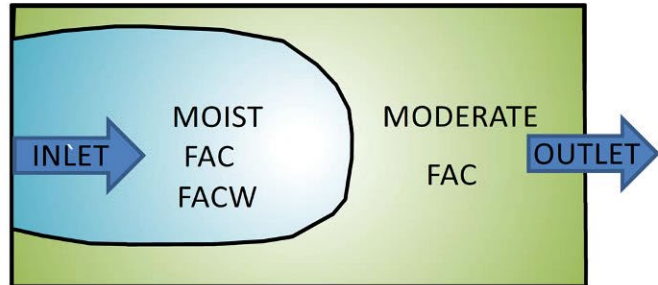

RAIN GARDENS

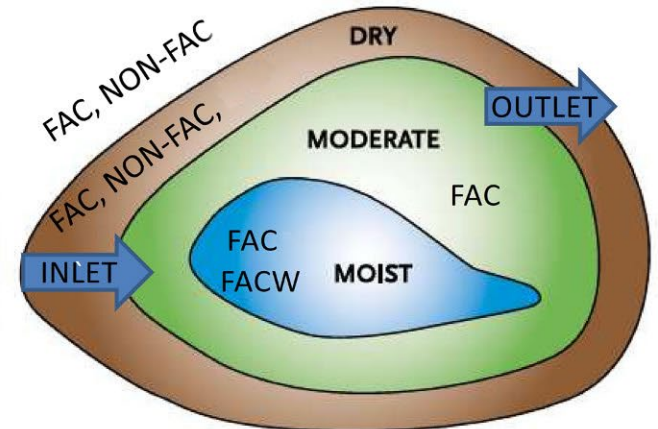
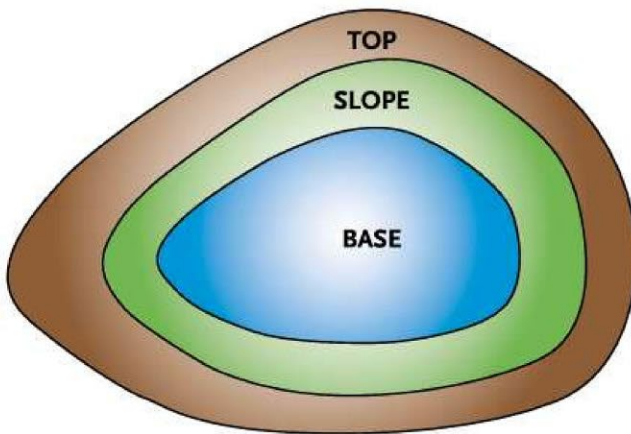

SWALES

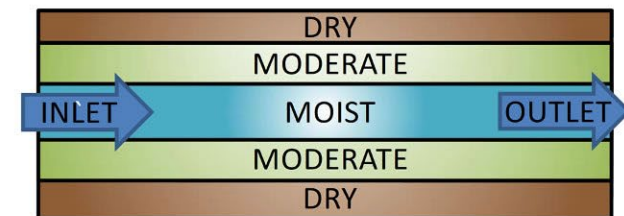

Figure A-1. Wetland status indicator for the moisture zones found in a vegetated stormwater BMP.

PLANTING TECHNIQUES

Plants from nurseries can often be root-bound in their pots. If the roots aren't loosened and unwound, the roots will continue to twist around in the planting hole instead of growing downwards and outwards, causing poor plant establishment and high maintenance. Another key to low maintenance plants is to ensure that the roots have good contact with the soil.

To plant a tree, see the Standard Details in Appendix F.

Planting in Containers

To properly install plants in Contained Planters:

1. Fill your container with soil to within 4 to 5 inches of the top of the container.
2. Dig a hole twice the size of the pot the plant comes in. Keep the soil pile nearby and clear of leaves and other surface debris.
3. Take note of where the potting soil from the nursery level is compared to the stem of the plant. Many plants have a different color and texture on the section that sits below the soil than on the sections that sit above ground.
4. Gently shake the potting soil off as much of the roots as possible. The nutrition from the potting soil is likely to be exhausted.
5. For balled and burlapped trees, the soil may be left in. However, ensure that burlap or any other confining material will not impede root growth by removing at least the bottom half of the material.
6. Loosen the roots. For 4" root-bound plugs, use hand clippers to cut an X into the bottom of the root wad, then pull it apart to loosen the roots.
7. Taking some of the soil you dug out, create a mound at the bottom of the hole and lightly tamp it down.
8. Drape the plant roots around the mound so that they're touching the mound on the bottom and pointing downwards. There are two kinds of roots, larger structural roots and tiny feeder roots, which is where the plant "drinks" and "eats". In pot-bound plants, some roots may be really long and will just continue winding around the other plant roots. If they're very small feeder roots, shorten them by pulling them off to be a similar length as the other roots. A few of the bigger structural roots can be cut, but it's better to dig a deeper hole and get them pointed downward.
9. As you backfill the hole by pushing soil in around the tops of the roots, hold the plant so that the point at which the plant came out of the soil in its original pot will be the level where the final grade of soil in the contained planter will be (level of soil on the stem is the same). Plants that are planted too deep may drown or the stem may rot. Plants that are too high may not have enough feeder roots in the soil to survive.
10. When finished, tamp down the soil. If the container is very large, step around the stem of the plant. This, combined with previous steps, will ensure good root contact with the soil.
11. Place an organic mulch that meets the specifications in General Notes for Vegetated Facilities to a depth of 2 to 3 inches. For woody stems on shrubs or trees, push the mulch a few inches away or the stems could rot.

Planting in the Ground

To properly install plants in a Rain Garden, Stormwater Planter, LID Swale, Dispersion Facility, or Conveyance Swale, follow steps 2-11 for installing plants in a Contained Planter described above.

ESTABLISHMENT PERIOD MAINTENANCE

Native plants should be allowed to reseed before cutting the plant. When reseeding will occur depends on the chosen plant palette. As a general rule, most spring and summer blooming plants have seeded by August, and fall and winter blooming plants will have set their seed by January. Generally, most plants don't respond well when cut down to less than 6 inches high.

Timing of pruning is important. While common and correct horticultural practices might prune a shrub in the fall, when this is done to a shrub used for stormwater management, the shrub no longer has leaves to evapotranspire stormwater. This reduces the effectiveness of the BMP in reducing runoff.

Irrigation Guidelines

The goal during the establishment period is to make plants as "drought proof" as possible by watering deeply and infrequently. To establish perennial plants, you'll need to irrigate more in the first year and less to much less in

subsequent years. In addition, plants benefit from varying irrigation seasonally. At the beginning of summer, after the rains stop, water a little. Increase irrigation volume as the summer/dry season continues. Taper off irrigation as the rains start to come back.

The volume of water and frequency of watering varies with the type of plant, general guidelines:

- Trees: 5-10 gallons, once/week
- Shrubs: 3-5 gallons once/week
- Groundcover: 1-2 gallons, once or twice/week
- Perennial herbs: ½ gallon, twice/week.

After the 3 year establishment period, irrigation would theoretically not be needed; however plantings surrounded by impervious pavement or hot roofs will probably require occasional irrigation beyond the establishment period, indefinitely.

The City of Medford has put together a Plant Resource List that categorizes the amount of water required by different species from low to high, they also have irrigation system design requirements in their “Landscape and Irrigation Plan Processing Information Packet”. Both documents can be accessed here, <http://www.ci.medford.or.us/Page.asp?NavID=3066>

INTEGRATED PEST MANAGEMENT

Short and long-term maintenance of all landscape areas should be done using integrated pest management techniques.

According to the Oregon Department of Agriculture:

“Integrated pest management (IPM) refers to a coordinated decision-making and action process that uses the most appropriate pest control methods and strategies in an environmentally and economically sound manner to meet agency pest management objectives.

The elements of integrated pest management include the following:

- Preventing pest problems by focusing on developing healthy plant environments (fostering healthy soils, maintaining air flow and utilizing right plant right place techniques)
- Monitoring for the presence of pests and pest damage
- Establishing the density of the pest population, which may be set at zero, that can be tolerated or correlated with a damage level sufficient to warrant treatment of the problem based on health, public safety, economic, or aesthetic thresholds
- Treating pest problems to reduce populations below those levels established by damage thresholds using strategies that may include biological, cultural, mechanical, and chemical control methods and that shall consider human health, ecological impact, feasibility, and cost effectiveness
- Evaluating the effects and efficacy of pest treatments

Pest refers to any vertebrate or invertebrate animal, pathogen, parasitic plant, weed, or similar organism that can cause disease or damage to crops, trees, shrubs, grasses or other plants, humans, animals, or property” (Oregon Department of Agriculture [a]).

For additional resources including the PNW Insect Handbook, PNW Plant Disease Handbook, and the PNW Weed Handbook, visit the Oregon Department of Agriculture website:

<http://www.oregon.gov/ODA/programs/Pesticides/RegulatoryIssues/Pages/IPM.aspx>.

Weeding

Weeding frequency is generally recommended to be a minimum of twice a year in May and October, but should also be timed to pull whatever invasive plants are on-site before they go to seed. Hand pulling or other mechanical removal technique is preferred. In particular, pesticides, herbicides, and fertilizers should generally be avoided in maintaining any of the BMPs in this guidance as these are pollutants that are easily conveyed in stormwater runoff.



Figure A-2. Since weeds need water in the summer but the right natives won't, substantial irrigation beyond the establishment period will only increase maintenance.

SOURCING PLANTS

Plants may be sourced from a variety of nurseries. Choosing healthy, appropriate specimens is key to high functioning facilities. Some tips for sourcing plants are as follows:

- A list of native plant nurseries can be found on Rogue Valley Sewer Services website: <http://www.rvss.us/pilot.asp?pg=phase2> Plants should be from seeds adapted to either clayey or sandy soil type, according to the on-site soils.
- Plants should be from seeds gathered as locally as possible. For instance, a native alder grown from seed collected in Tillamook County will not be as well adapted to the Rogue Valley.
- An informative slide show on southwest Oregon species by Linda McMahan of OSU Extension is available <http://www.slideshare.net/lindamcmahan/native-plants-for-southwestern-oregon>.

REFERENCES

Emmanuel, R., Ph.D., Clean Water Services, Hillsboro, OR, personal communication. (2010).

Invasive Species Council of California (ISCC). The California Invasive Species List. Retrieved from: <http://www.iscc.ca.gov/species.html>

Native Plant Society of Oregon (NPSO) [a]. Retrieved from: <http://www.npsoregon.org/landscaping5.php>

Native Plant Society of Oregon (NPSO) [b]. Exotic Gardening and Landscaping Plants Invasive in Native Habitats of the Southern Willamette Valley. Retrieved from: http://emerald.npsoregon.org/inv_ornmtns.html

Oregon Department of Agriculture [a]. Integrated Pest Management (IPM). Retrieved from: <http://www.oregon.gov/ODA/programs/Pesticides/RegulatoryIssues/Pages/IPM.aspx>

Oregon Department of Agriculture. (2016). Oregon Noxious Weed Profiles. Retrieved from: <http://www.oregon.gov/ODA/programs/Weeds/OregonNoxiousWeeds/Pages/AboutOregonWeeds.aspx>

Washington State Noxious Weed Control Board (NWCB). Retrieved from: <http://www.nwcb.wa.gov/>

Appendix F: General Notes, Standard Drawings and Standard Details

Details are currently available in pdf and AutoCAD format and may be downloaded from [Rogue Valley Sewer Services website](#).

Construction Notes and Material Specifications for Stormwater Facilities

These notes must be included on the plans for all BMPs.

List of Standard Drawings

BMP 4.4.1.a Poned Retention: Rain Garden

BMP 4.4.1.b Poned Retention: Rain Garden Planting Schematic

BMP 4.4.1.c Poned Retention: Stormwater Planter with Area Drain

BMP 4.4.1.d Poned Retention: Stormwater Planter Planting Schematic

BMP 4.4.2.a Pervious Surface: Pervious Concrete Pavement

BMP 4.4.2.b Pervious Surface: Pervious Asphalt Pavement

BMP 4.4.2.c Pervious Surface: Permeable Pavers

BMP 4.4.2.d Pervious Surface: Vehicular Permeable Paver Edges

BMP 4.4.3.a Underground Retention: Soakage Trench in Landscape Area

BMP 4.4.3.b Underground Retention: Soakage Trench under Impervious Pavement Surface

BMP 4.5.1. Soil Filtration

BMP 4.5.2.a Water Quality Swale

BMP 4.5.2.b Water Quality Swale: Planting Schematic

BMP 4.5.3 Vegetated Filter Strip with Amended Planting Soil

Standard Details

1.01 Roadway Curb Opening

1.02 Check Dam

1.03 Flow Spreader

1.04 Forebay

1.05 Tree Protection

1.06 Tree Protection – Temporary Access Road

1.07 Tree Planting

1.08 Tree Planting on Slope

CONSTRUCTION NOTES AND MATERIAL SPECIFICATIONS FOR STORMWATER FACILITIES
THESE NOTES MUST ACCOMPANY ALL STANDARD DRAWINGS.

GENERAL STORMWATER CONSTRUCTION NOTES

1. All Stormwater facilities must be constructed per the Design Manual, or as approved by the local jurisdiction.
2. Call the reviewing agency 48 hours in advance of constructing this facility so construction observation may be performed to identify variations in the field that may affect design and verify proper construction.
3. For infiltration facilities, exposed facility subgrade shall be fenced to prohibit impacts from construction (including materials and equipment storage). If unprotected subgrade has been exposed to rainfall, scarify the surface to a depth of 4 inches to restore filtration capacity.
4. Placement of amended native or imported soil mix shall occur as follows:
 - o Conduct excavation, fine grading and placement work only when the facility and soil to be placed is dry. Do not place if soil is saturated.
 - o Place soil in 8 inch maximum lifts.
 - o Lightly compact each lift, (e.g. a water filled landscape roller) to achieve 85% compaction. Do not compact with heavy machinery or vibratory compaction.
5. All ground within the facility must be stabilized with one of the options below, also see Material Specifications for Stormwater Facilities.
 - o **Hydroseeding** – Hydroseeding with tackifier.
 - o **Matting** – Matting shall be used to hold the soil in place until vegetation becomes established. If hand seeding, place seed and then install erosion control matting. If planting, install erosion control matting and then install plants through the matting. Matting is not required on slopes 4H:1V or shallower, or on slopes that have been hydroseeded.
 - o **Mulch** – Mulch is not allowed below the water quality ponding depth or within the flow path of an inlet or outfall. Mulch shall be spread over bare soil or in a ring around plants. Ensure that mulch does not touch plant stems.
6. If soil is placed during the wet season the facility must be stabilized within one week of soil installation.

CONSTRUCTION NOTES FOR VEGETATED STORMWATER BMPS

7. Build and vegetate as early as possible to establish plantings prior to directing stormwater runoff to the BMP.
8. Contact approving jurisdiction 48 hours in advance of planting so that the jurisdiction can review soil installation and plant placement prior to plant installation.

CONSTRUCTION NOTES FOR PERVIOUS SURFACE STORMWATER BMPS

9. Contact the approving agency 48 hours prior to placing geotextile fabric. The approving agency may call the engineer of record in advance of constructing this facility so construction observation may be performed to identify variations in the field that may affect design and verify proper construction.

MATERIAL SPECIFICATIONS FOR STORMWATER FACILITIES

1. Growing media must be Imported Planting Soil or Amended Native Soil at the depths shown on the Standard Drawings and meet the following specifications:
 - a) **Imported Water Quality Mixture** – Is based on the ODOT “Water Quality Mixture” 01012, and shall be comprised of soil meeting the gradation in the table below and compost meeting ODOT Standard Specification Section 03020.

Soil Gradation Requirements	
Sieve Size	Percent Passing (by Weight)

No. 4	100
No 10	95 - 100
No. 40	40 - 60
No. 100	10 - 25
No. 200	5 - 10

Mix the soil and compost so the Imported **Water Quality Mixture**:

- Is comprised of between 20%-25% compost and between 75%-80% soil.
- Has a pH between 5.5 and 8.0.
- Does not have clumps greater than 3 inches in any direction.

b) **Amended Native Soil** – Add compost so that the top 18 inches is roughly 30% compost meeting ODOT Standard Specification Section 03020.

i) The approving jurisdiction may request evidence that the Amended Native Soil or Imported Water Quality Mixture meets specification prior to placement. If requested, test data for the soil mix shall be provided by an accredited laboratory with current certification. The date of the analyses must be no more than 90 days prior to submittal. The report must include the following:

- Name and address of the laboratory
- Phone, contact and email address of the laboratory
- Test data, including date and name of the test procedure
- Source of the topsoil

2. Matting shall be ODOT Type E erosion control matting.
3. Mulch shall be a 2 inch thick layer of dye, pesticide, and weed free shredded wood chips or coarse compost.
4. Stormwater facility geotextiles shall be ODOT Drainage Geotextiles Type 1, non-woven, per Standard Specification Section 03020. Geotextile under the road base in 4.5.3 shall be Subgrade Geotextile meeting ODOT Standard Specification Section 02320.
5. Impermeable liners may be a 30 mil (minimum) low density polyethylene (ldpe), 30 mil (minimum) ethylene propylene diene monomer (epdm) or bentonite clay mat per manufacturer guidance.
 - a. Stormwater facilities with liners that are planted with shrubs must have 24 inches of imported soil.
6. Unless otherwise approved, rock for Pervious Surface BMP's and Stormwater Facilities shall be crushed rock per ODOT Standard Specification Sections 00430.11 (Granular Drain Backfill Material) or 02690.20 (Course Aggregate) and meet the following gradations:

Sieve Size	Percent Passing (by weight)		
	Designated Sizes		
	Granular Drain Backfill	Granular Drain Backfill	Course Aggregate
	1 1/2" - 3/4"	3/4" - 1/2"	3/8" – No. 8
2"	100	-	-
1 1/2"	95 - 100	-	-
1"	-	100	-
3/4"	0 - 15	90 - 100	-
1/2"	0 - 2	0 - 15	100
3/8"	-	-	85 - 100
1/4"	-	0 - 3	-

No. 4	-	-	10 - 30
No. 8	-	-	0 - 10
No. 16	-	-	0 - 5

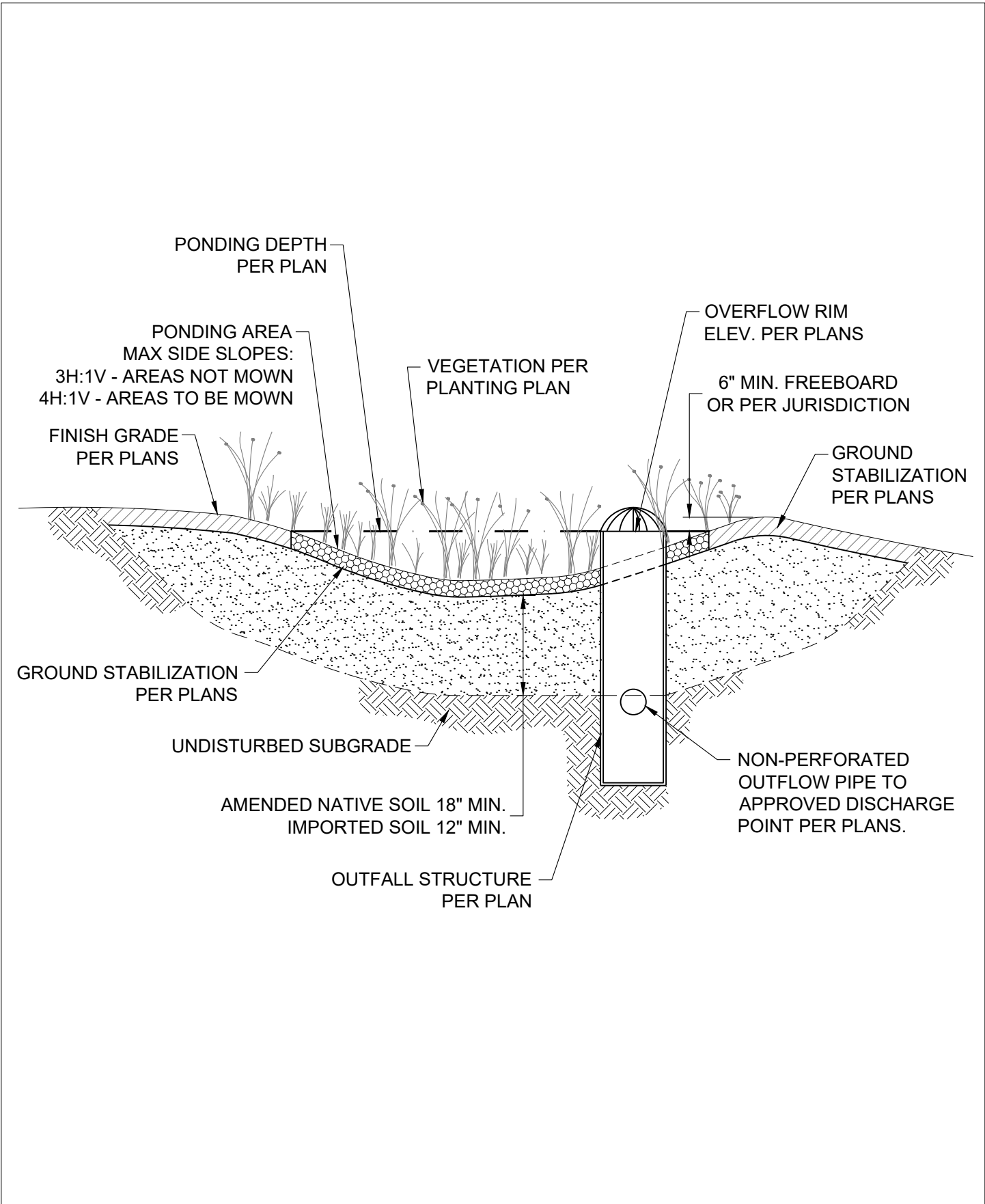

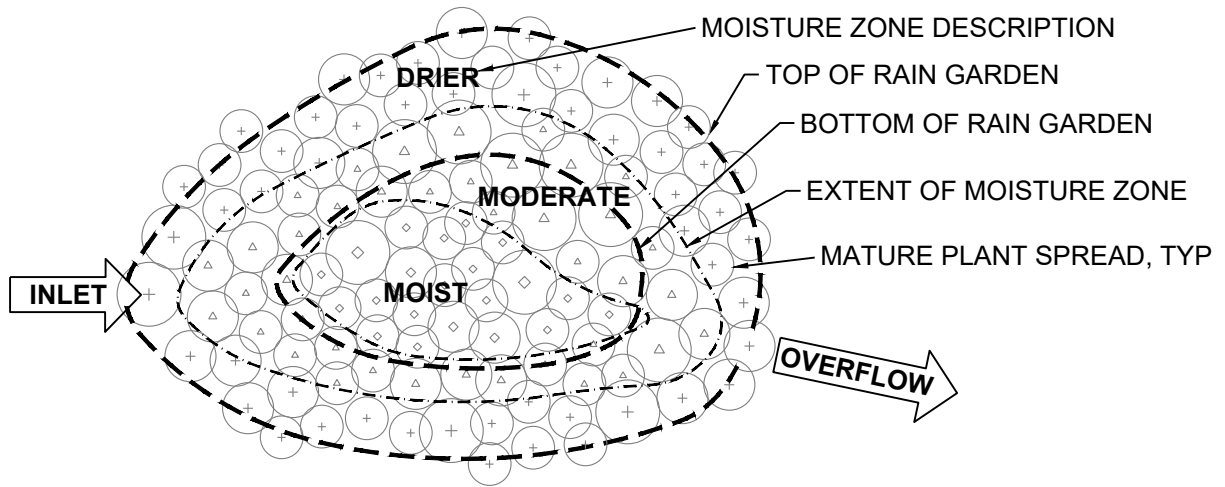

PROFILE VIEW

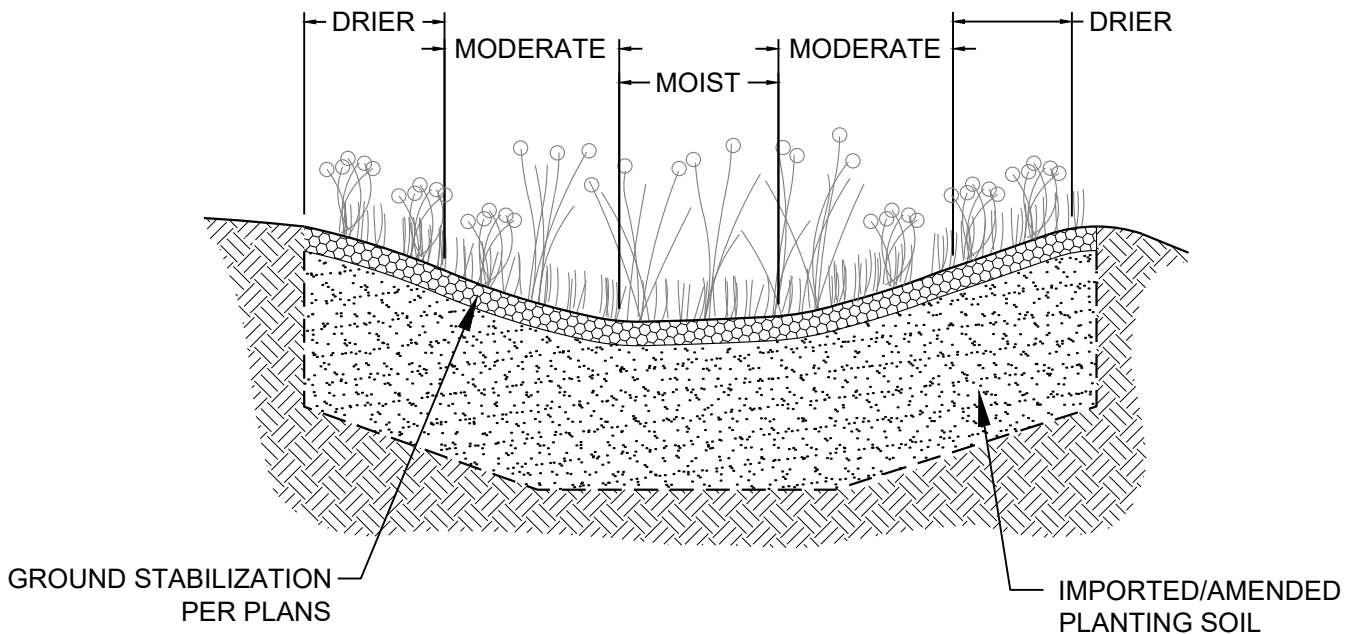

LEGEND:

— — CONTOUR LINE

- - - MOISTURE ZONE

PLANT SPECIES APPROPRIATE FOR MOISTURE ZONE:

⊕ DRIER

⊕ MODERATE

⊕ MOIST

NOTES:

1. THIS DETAIL IS PROVIDED AS A SCHEMATIC EXAMPLE OF THE RANDOM PLANT PLACEMENT AND 95% COVERAGE AFTER ESTABLISHMENT PERIOD DESIRED TO REDUCE EROSION AND WEEDS.
2. INSTALL PLANTS PER PLANS, ACCORDING TO LANDSCAPE DESIGN PLANT TABLE, WHICH SHOULD INCLUDE PLANT SPECIES, SPACING, AND QUANTITIES IN EACH MOISTURE ZONE.
3. MOISTURE ZONES VARY FROM THOSE SHOWN DEPENDING ON GRADING PLAN, LOCATION OF INLET (S) AND OUTLET(S) AND FACILITY SHAPE.

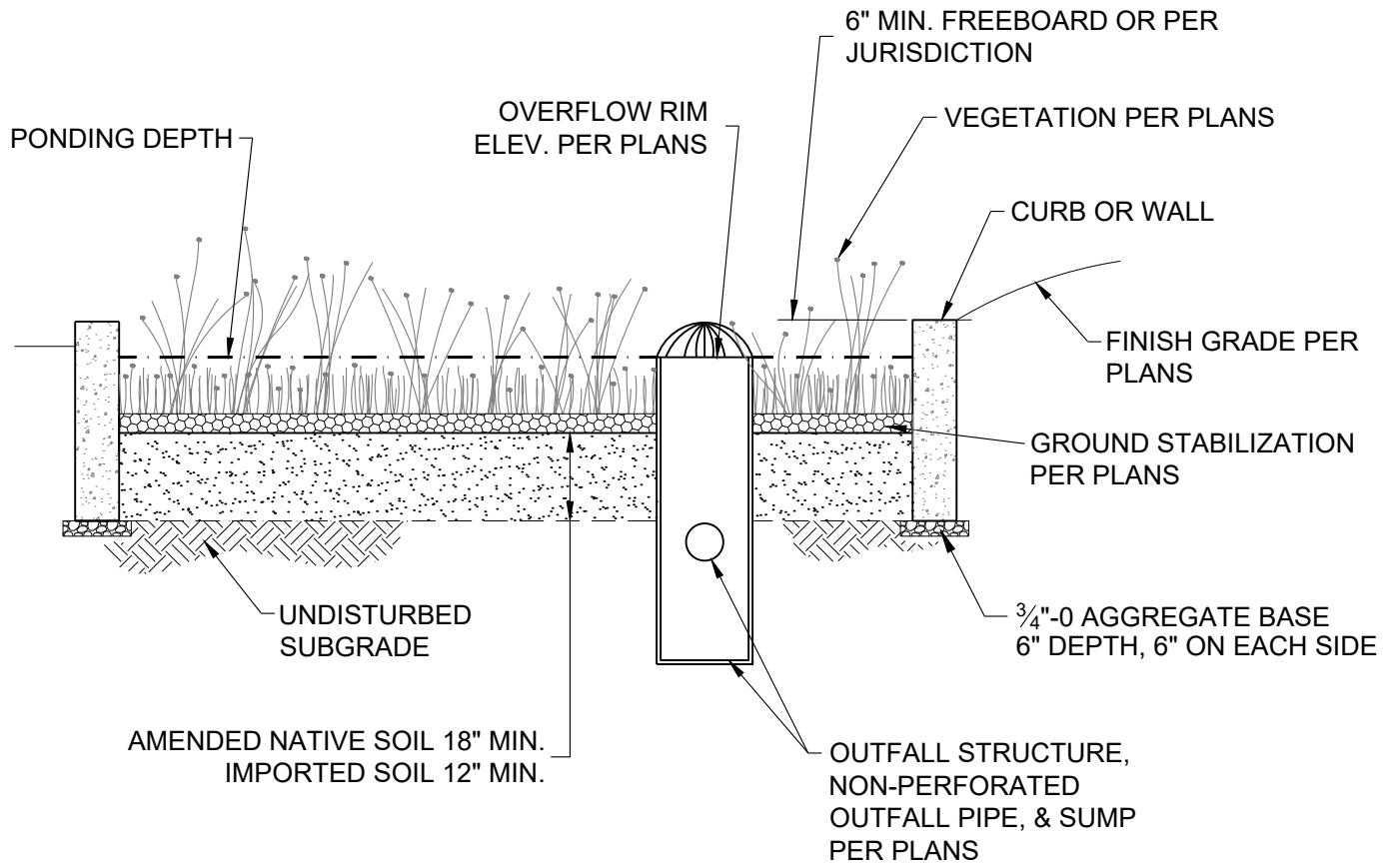

<p>Rogue Valley Stormwater Design Manual</p>	<p>Pondered Retention: Stormwater Planter with Area Drain</p>	<p>BMP 4.4.1.c 1 of 1 Scale: NTS</p>
--	---	--

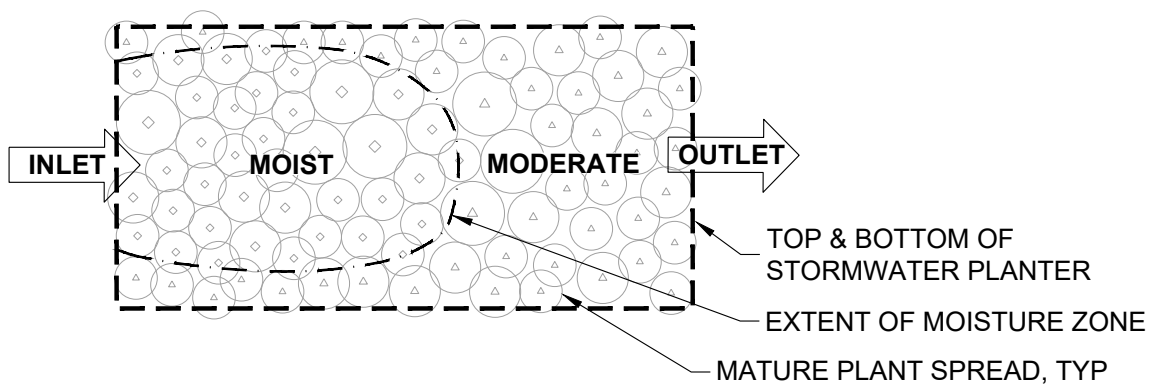

LEGEND:

— — CONTOUR LINE

- · - MOISTURE ZONE

PLANT SPECIES APPROPRIATE FOR MOISTURE ZONE:

△ MODERATE

◇ MOIST

NOTES:

1. THIS DETAIL IS PROVIDED AS A SCHEMATIC EXAMPLE OF THE RANDOM PLANT PLACEMENT AND 95% COVERAGE AFTER ESTABLISHMENT PERIOD DESIRED TO REDUCE EROSION AND WEEDS.
2. INSTALL PLANTS PER PLANS, ACCORDING TO LANDSCAPE DESIGN PLANT TABLE , WHICH SHOULD INCLUDE PLANT SPECIES, SPACING, AND QUANTITIES IN EACH MOISTURE ZONE.
3. MOISTURE ZONES VARY FROM THOSE SHOWN DEPENDING ON GRADING PLAN, LOCATION OF INLET (S) AND OUTLET(S) AND FACILITY SHAPE.

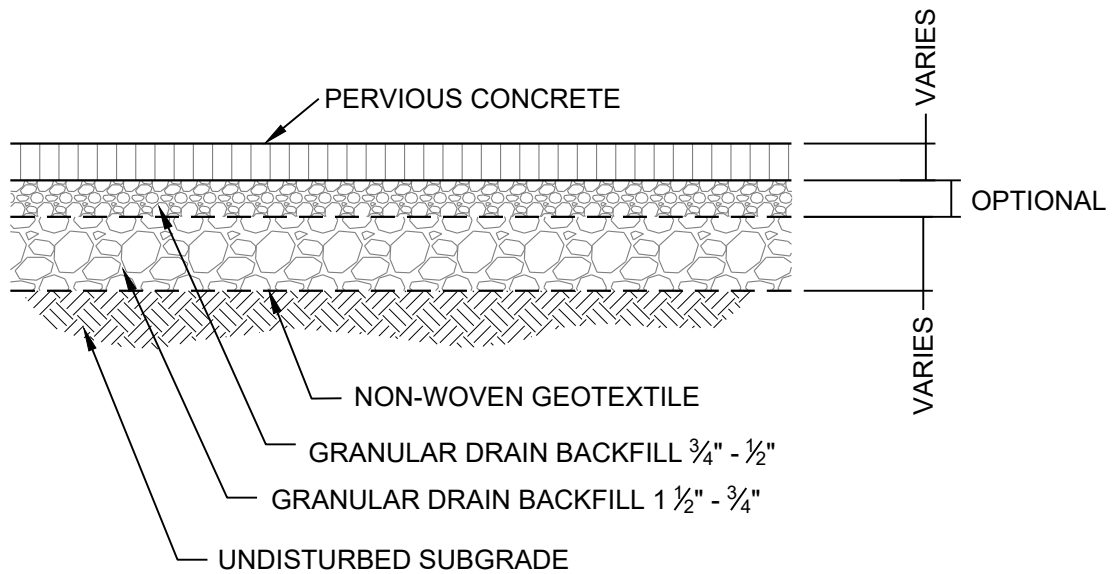

NOTES

- DESIGN AND INSTALL PERVIOUS CONCRETE IN ACCORDANCE WITH AMERICAN CONCRETE INSTITUTE SPECIFICATION 522 AND THE NATIONAL READY MIXED CONCRETE ASSOCIATIONS (NRMCA) RECOMMENDATIONS.

<p>Rogue Valley Stormwater Design Manual</p>	<p>Pervious Surface: Pervious Concrete Pavement</p>	<p>Dwg BMP 4.4.2.a 1 of 1</p>
--	---	---------------------------------------

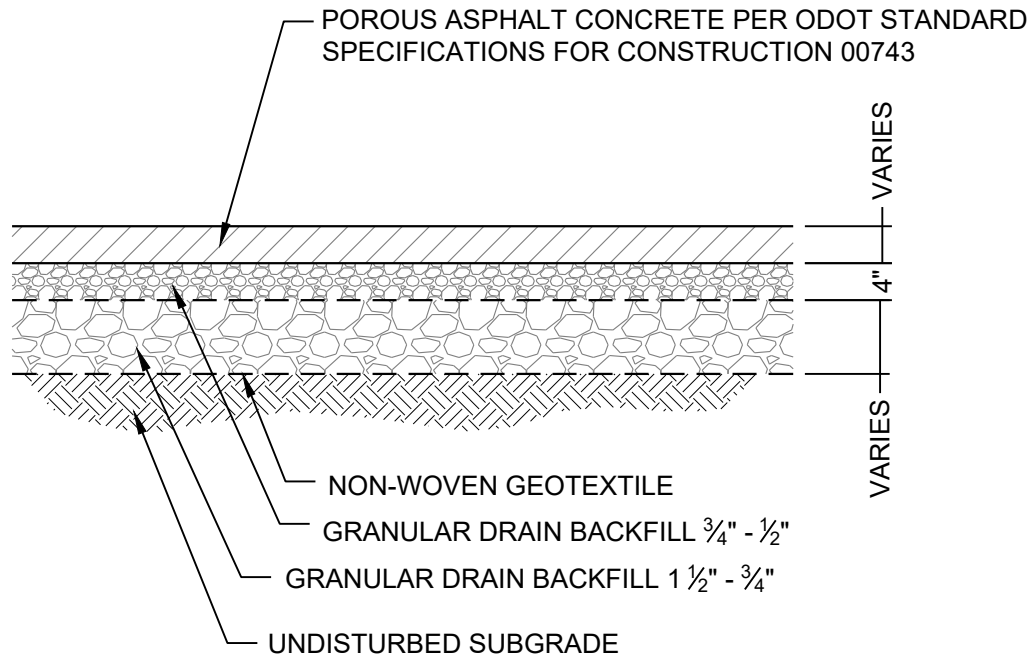

NOTES

1. FOLLOW ODOT SPECIFICATION 00743 POROUS ASPHALT CONCRETE.
2. MUST USE ELASTOMERIC BINDER PG7022ER, OR APPROVED EQUAL.
3. MUST PROVIDE THE JOB MIX FORMULA TO THE APPROVING AGENCY PRIOR TO CONSTRUCTION.

<p>Rogue Valley Stormwater Design Manual</p>	<p>Pervious Surface: Pervious Asphalt Pavement</p>	<p>Dwg BMP 4.4.2.b 1 of 1</p>
--	--	---------------------------------------

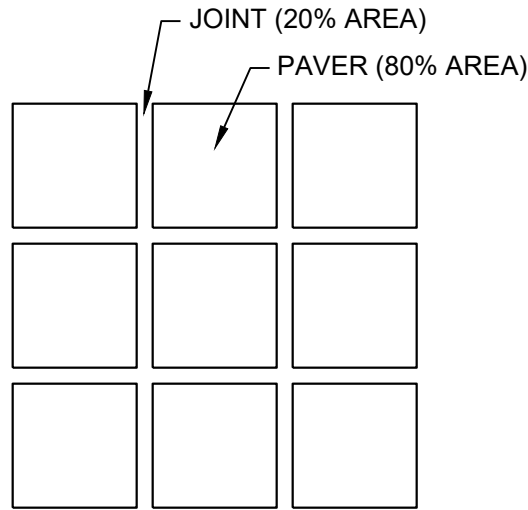
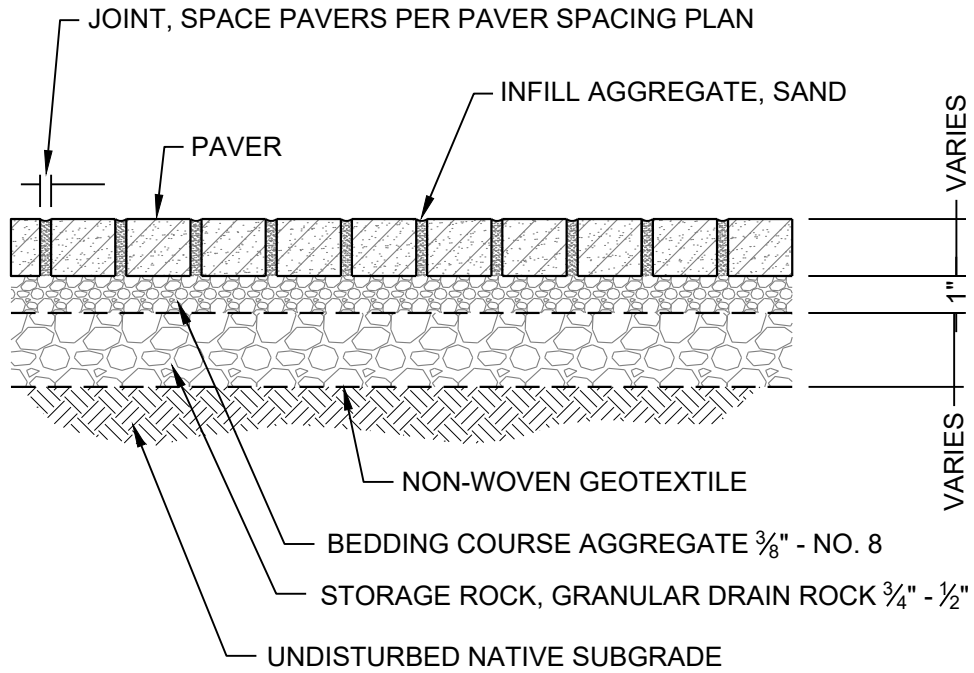

Paver Spacing Plan

NOTES

1. DESIGN & INSTALL CONCRETE PAVERS IN ACCORDANCE WITH THE INTERLOCKING CONCRETE PAVEMENT INSTITUTE (ICPI) SPECIFICATIONS & THE MANUFACTURER'S RECOMMENDATIONS.
2. IF USING SALVAGED AND POURED CONCRETE PAVERS, CONFIRM THAT THE PAVER MATERIAL AND CONDITION IS SUITABLE FOR ITS INTENDED USE.

Rogue Valley Stormwater Design Manual	Pervious Surface: Permeable Pavers	Dwg BMP 4.4.2.c 1 of 1
---	---------------------------------------	------------------------------

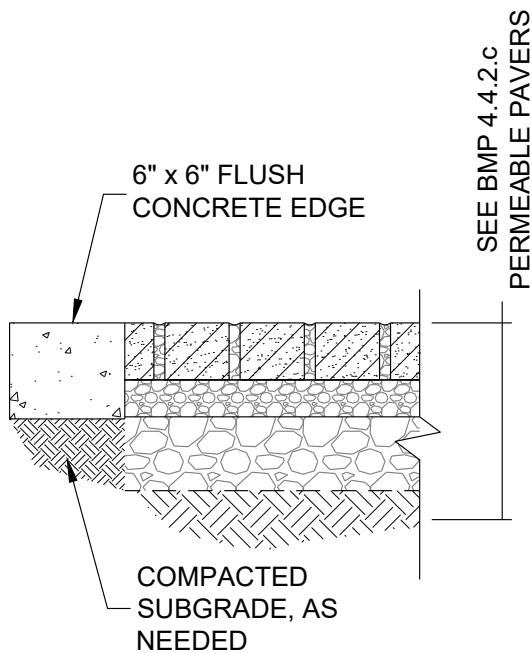

FLUSH CURB

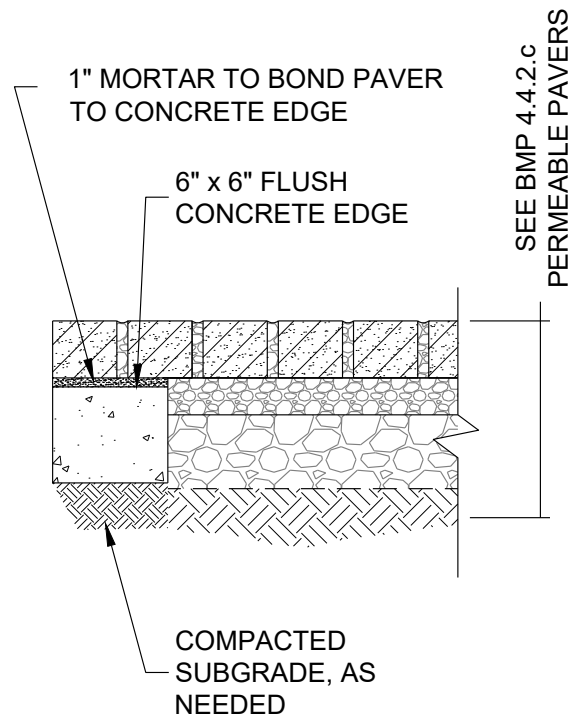

HIDDEN CURB

NOTES

1. DURING INSTALLATION OF CURB, PROTECT PERMEABLE PAVER AREA FROM COMPACTION.

<p>Rogue Valley Stormwater Design Manual</p>	<p>Pervious Surface: Vehicular Permeable Paver Edges</p>	<p>Dwg BMP 4.4.2.d 1 of 1</p>
--	--	---------------------------------------

Soakage Trench in Landscape Area

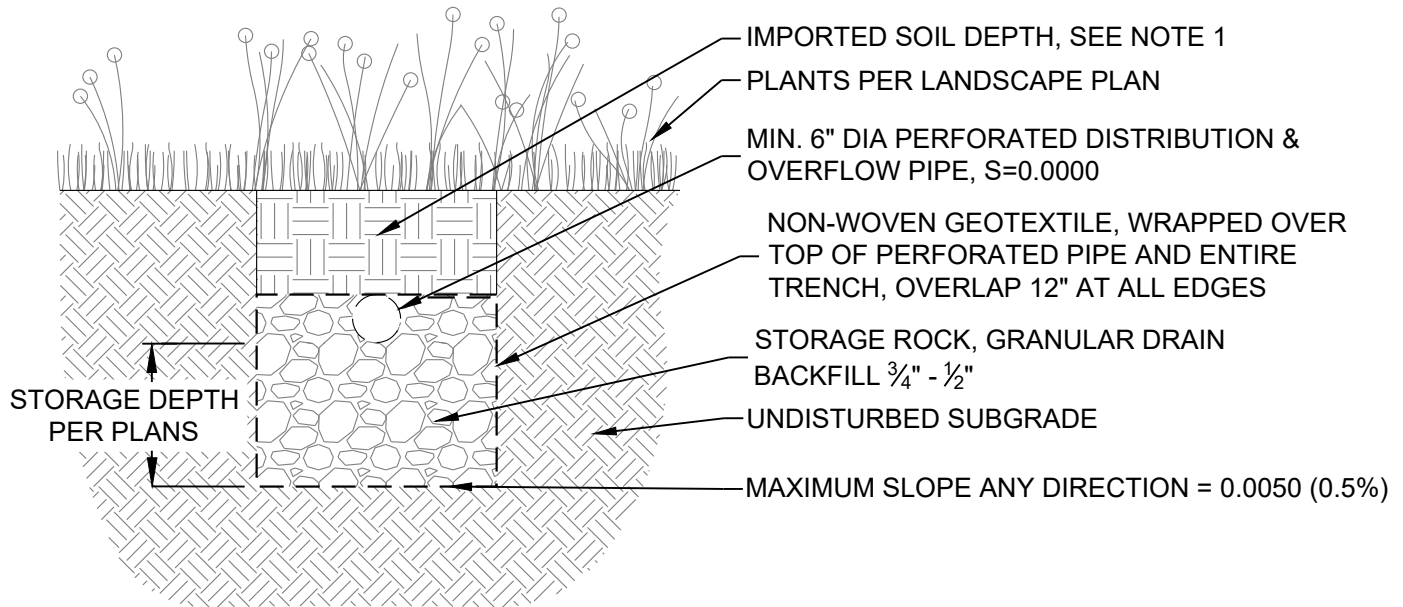

NOTES

1. DEPTH TO PIPE MUST BE 12" MINIMUM FOR ADEQUATE SOIL DEPTH PER PLANT CHOICES:
 12" FOR GRASSES/FORBS
 24" FOR SHRUBS
 36" FOR MOST TREES

Soakage Trench at Surface

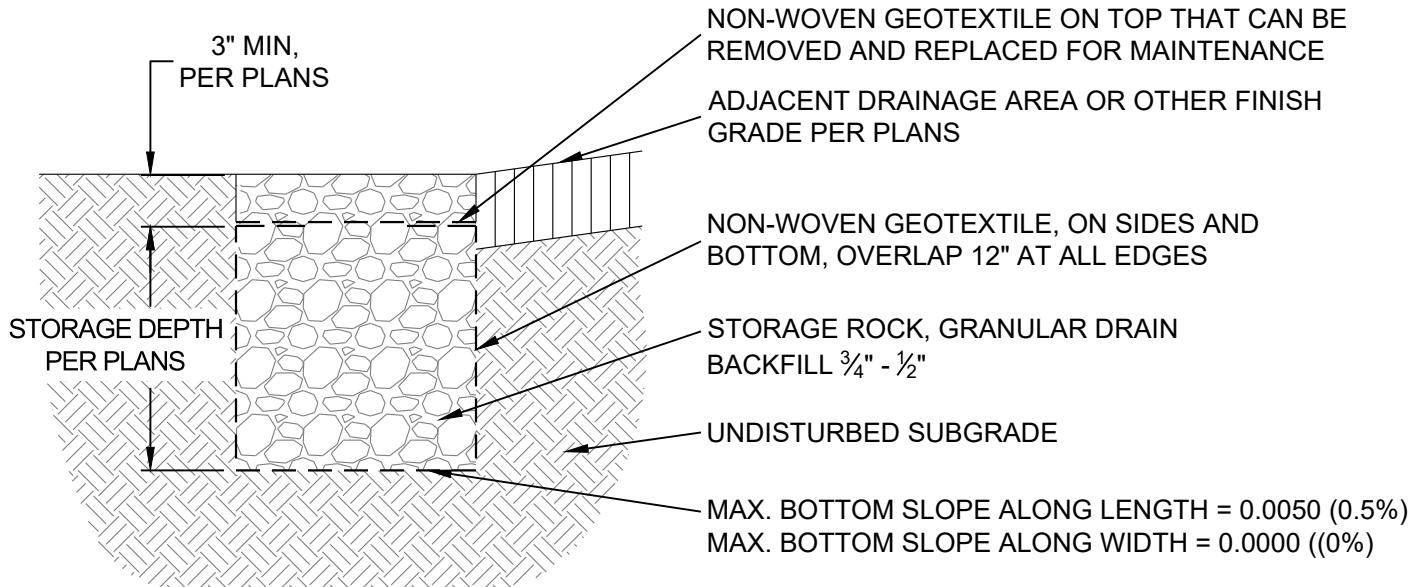

UIC AUTHORIZATION (NOT ALWAYS REQUIRED):

IF WATER IS DIRECTLY DISCHARGED TO THE SUBSURFACE, THE FACILITY MAY BE CONSIDERED A UIC AND MIGHT REQUIRE DEQ AUTHORIZATION. CONTACT DEQ TO FIND OUT ABOUT CURRENT UIC REGULATIONS AND WHETHER AUTHORIZATION WILL BE REQUIRED. DEQ'S UIC WEBPAGE: [HTTP://WWW.OREGON.GOV/DEQ/WQ/WQPERMITS/PAGES/UIC.ASPX](http://www.oregon.gov/deq/wq/wqpermits/pages/uic.aspx).

<p>Rogue Valley Stormwater Design Manual</p>	<p>Underground Retention: Soakage Trench in Landscape Area</p>	<p>BMP 4.4.3.a 1 of 1 Scale: NTS</p>
--	--	--

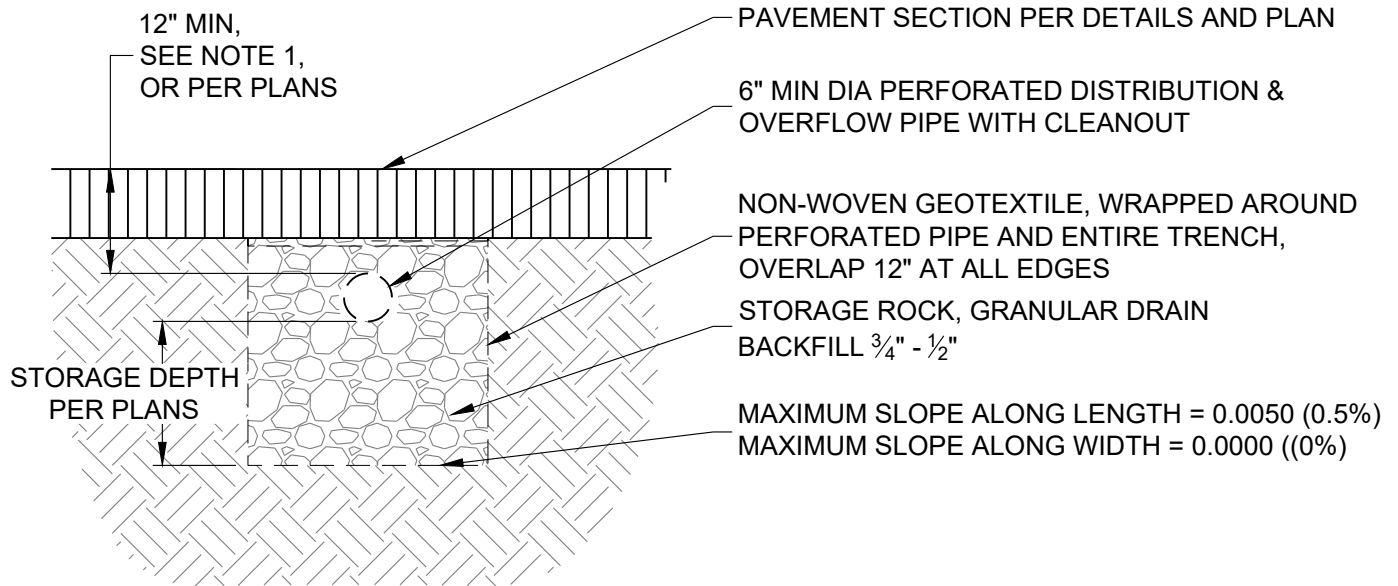

NOTES

1. PROVIDE DEPTH TO PIPE NEEDED FOR ADEQUATE COVER BASED ON VEHICULAR LOADING, WHICH VARIES WITH PIPE MANUFACTURER.

UIC AUTHORIZATION (NOT ALWAYS REQUIRED):

IF WATER IS DIRECTLY DISCHARGED TO THE SUBSURFACE, THE FACILITY MAY BE CONSIDERED A UIC AND MIGHT REQUIRE DEQ AUTHORIZATION. CONTACT DEQ TO FIND OUT ABOUT CURRENT UIC REGULATIONS AND WHETHER AUTHORIZATION WILL BE REQUIRED. DEQ'S UIC WEBPAGE: [HTTP://WWW.OREGON.GOV/DEQ/WQ/WQPERMITS/PAGES/UIC.ASPX](http://www.oregon.gov/deq/wq/wqpermits/pages/uic.aspx).

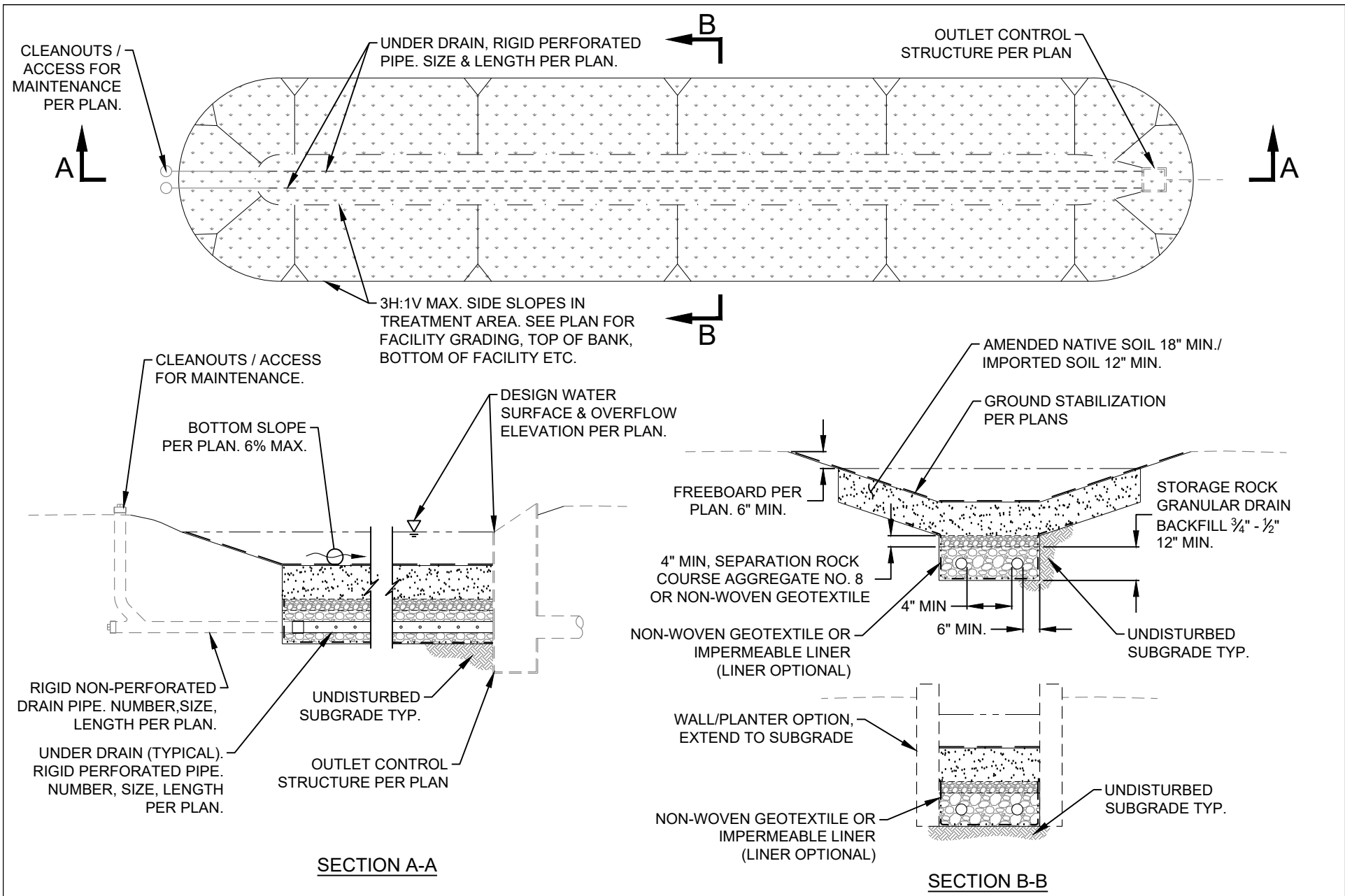

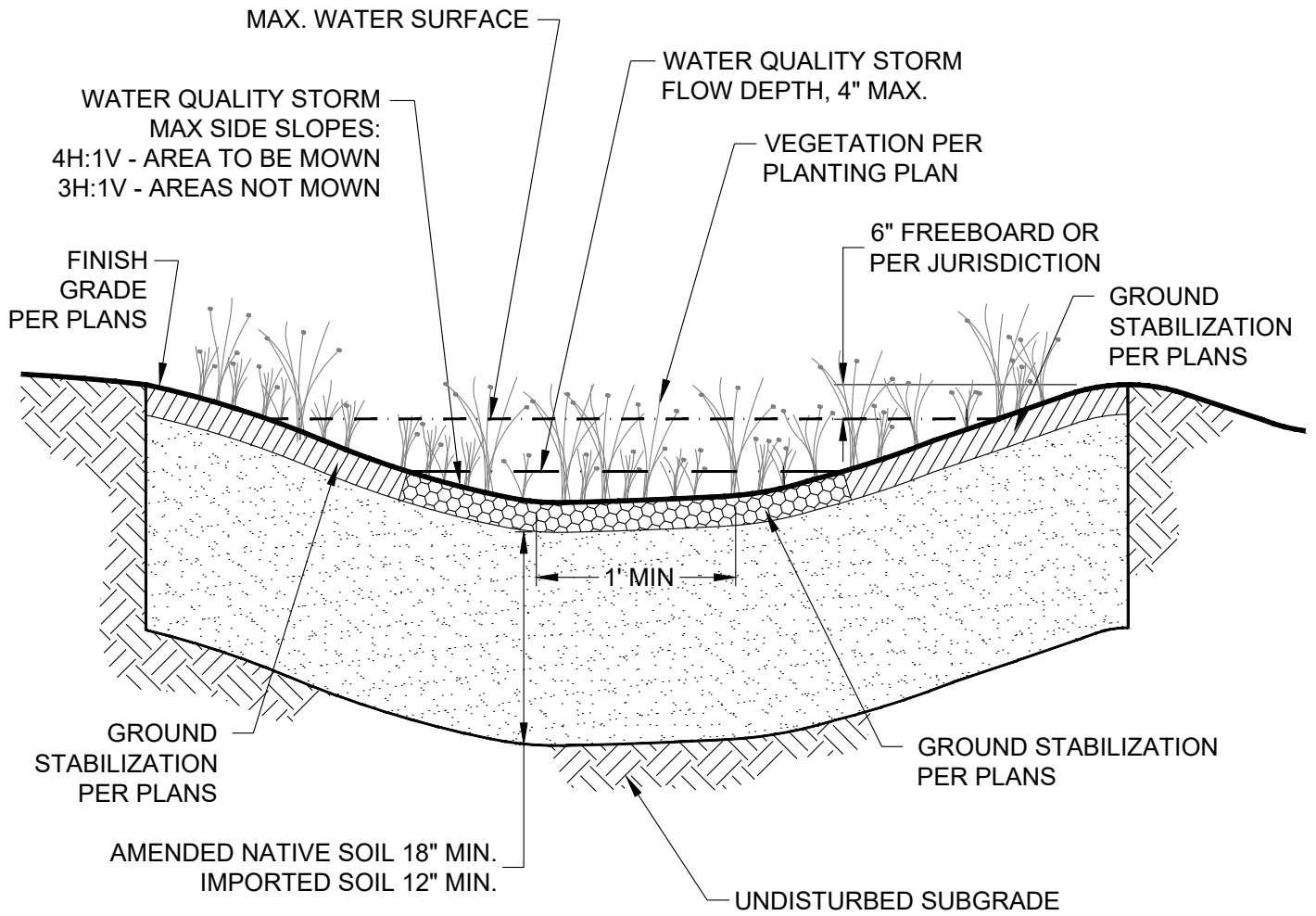

PLAN VIEW

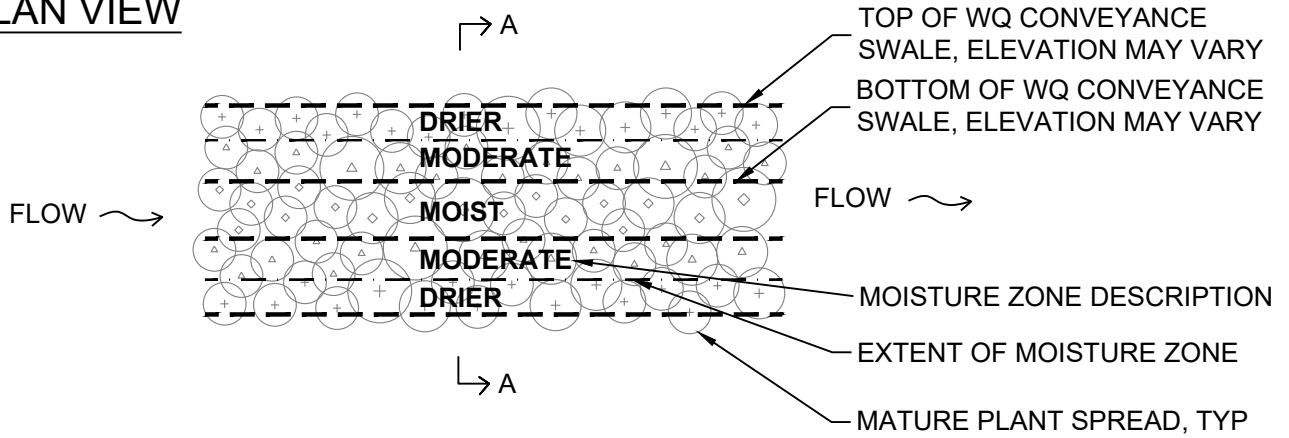

PROFILE VIEW

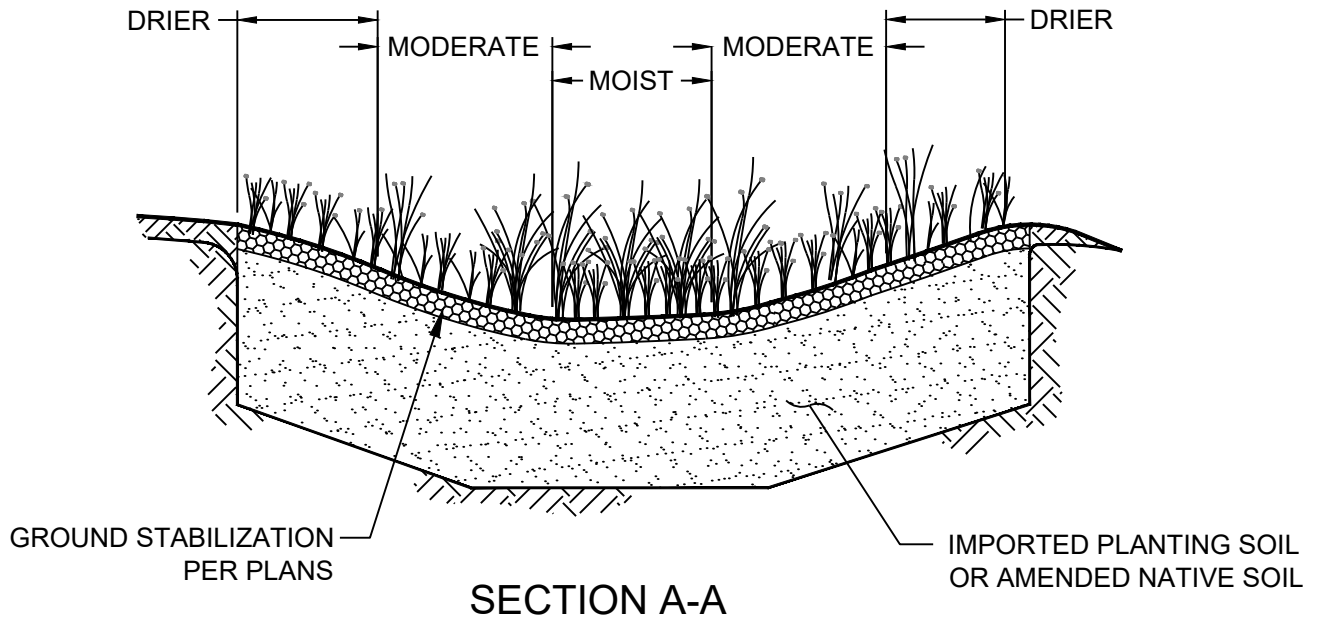

LEGEND:

— — INDICATES GRADE BREAK

- - - MOISTURE ZONE

PLANT SPECIES APPROPRIATE FOR MOISTURE ZONE:

- ⊕ DRIER
- △ MODERATE
- ◇ MOIST

NOTES:

1. THIS DETAIL IS PROVIDED AS A SCHEMATIC EXAMPLE OF THE RANDOM PLANT PLACEMENT AND 90% COVERAGE AFTER ESTABLISHMENT PERIOD DESIRED TO REDUCE EROSION AND WEEDS.
2. INSTALL PLANTS PER PLANS, ACCORDING TO LANDSCAPE DESIGN PLANT TABLE, WHICH SHOULD INCLUDE PLANT SPECIES, SPACING, AND QUANTITIES IN EACH MOISTURE ZONE.
3. MOISTURE ZONES VARY FROM THOSE SHOWN DEPENDING ON GRADING PLAN, LOCATION OF INLET(S) AND OUTLET(S) AND FACILITY SHAPE.

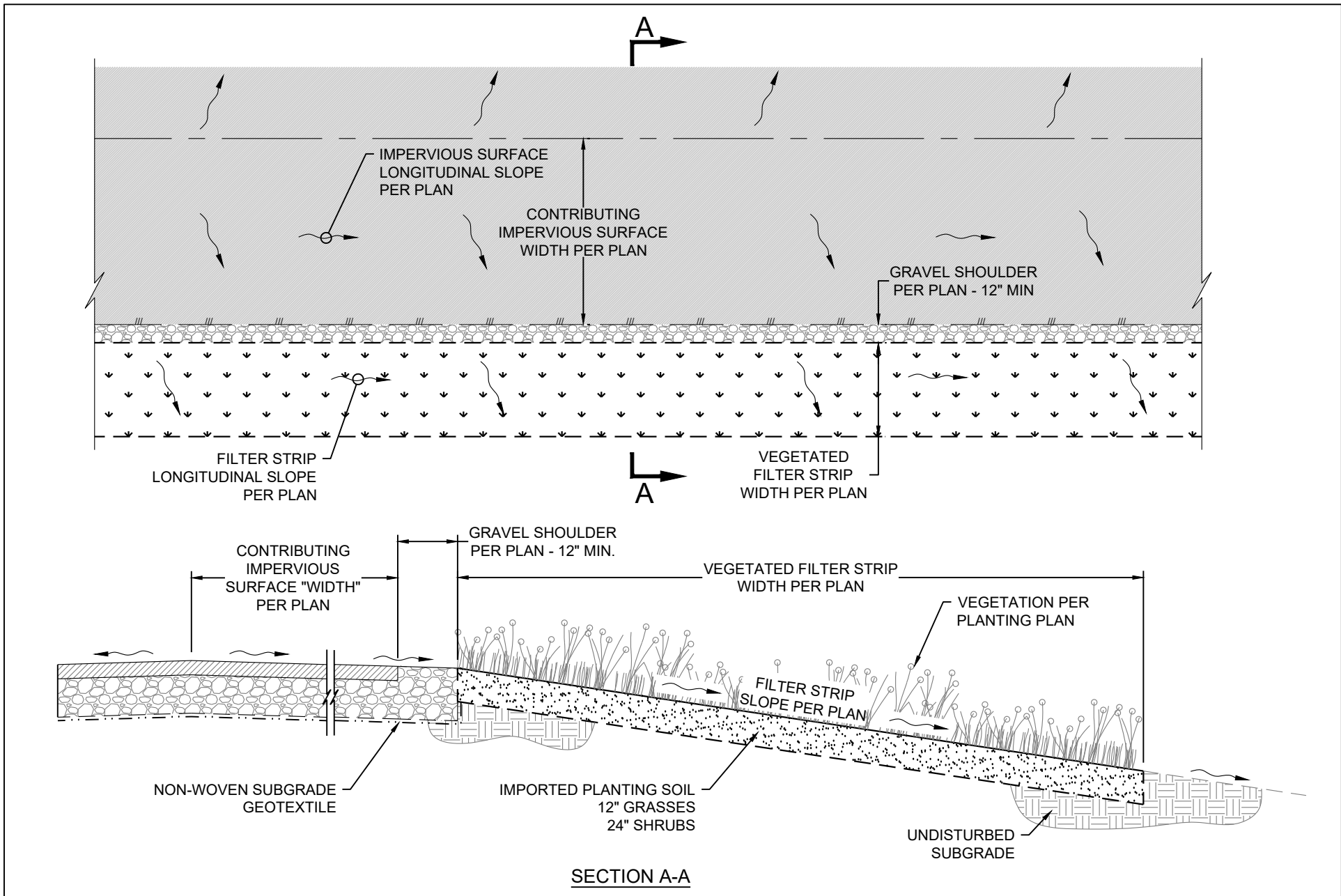

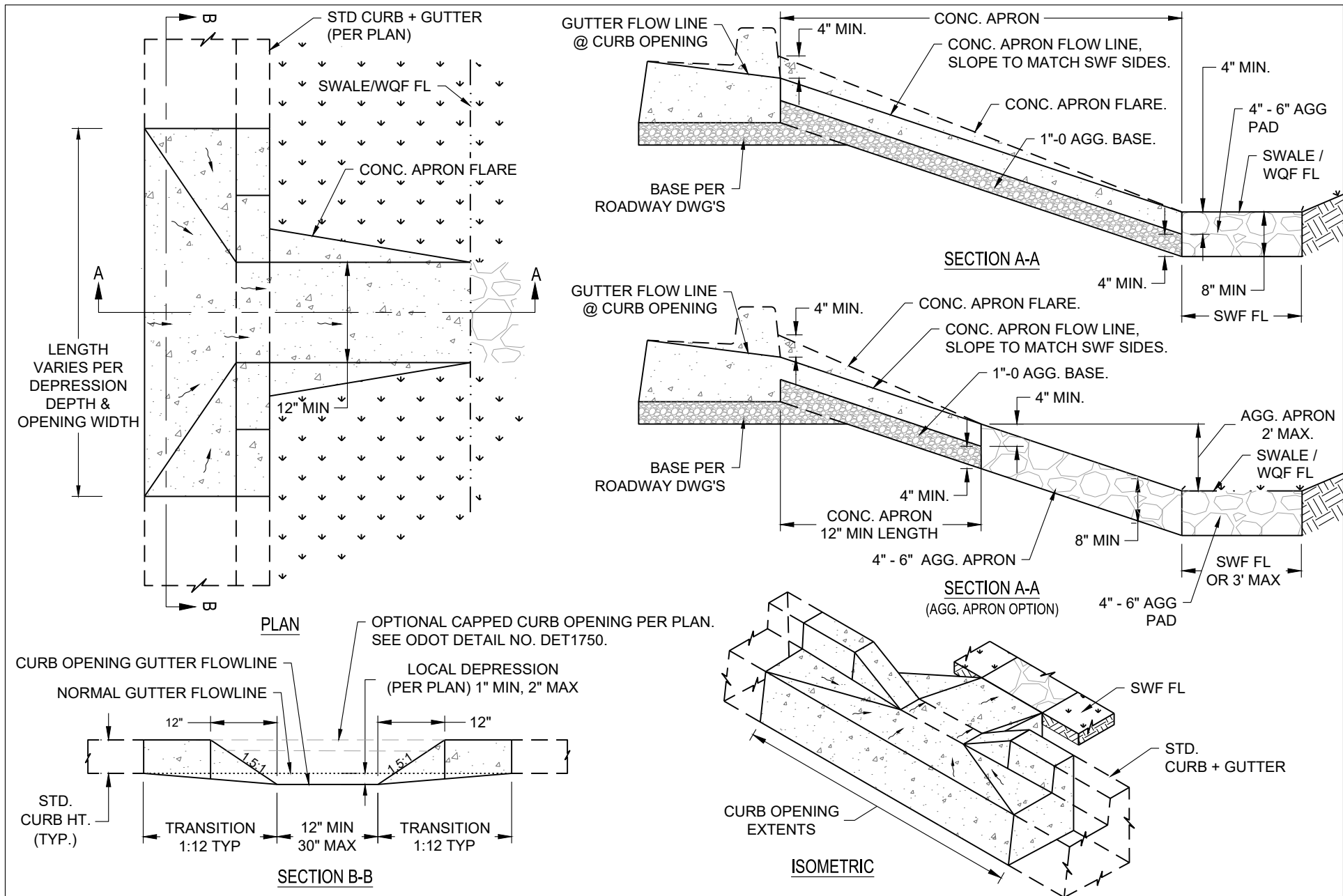

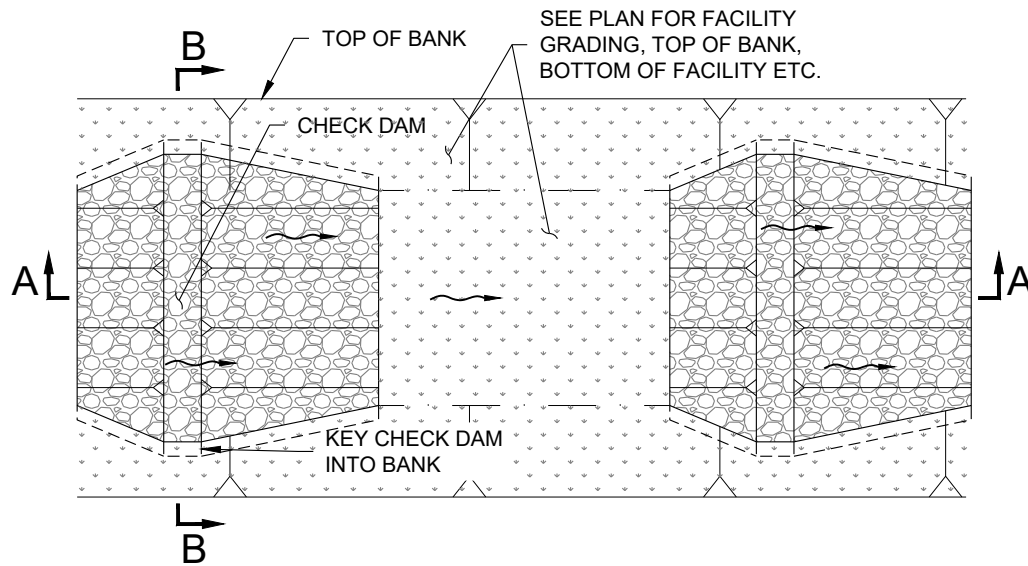

MAXIMUM CHECK DAM SPACING "L"		
SWALE GRADE	H = 18"	H = 24"
	10%	15'
9%	16'	22'
8%	18'	25'
7%	21'	28'
6%	25'	33'

H = MIN. DAM HEIGHT

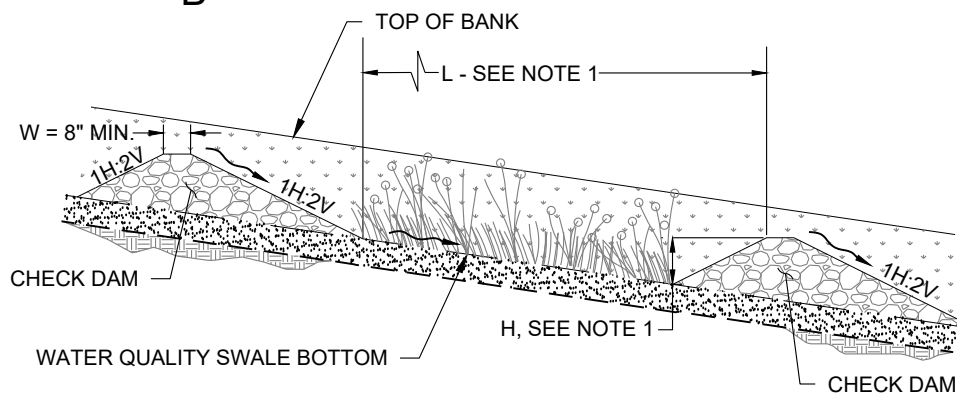

SECTION A-A

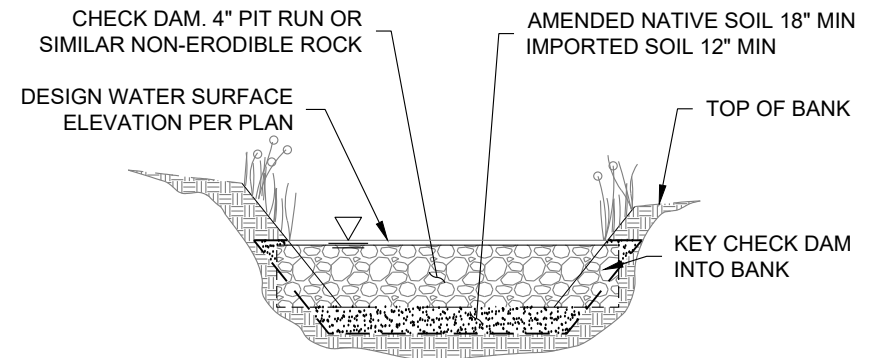

SECTION B-B

NOTES:

1. ELEVATION AT TOP OF DOWNSTREAM CHECK DAM SHALL BE EQUAL TO TOE OF UPSTREAM CHECK DAM. REFER TO TABLE FOR MINIMUM CHECK DAM SPACING AND HEIGHT REQUIREMENTS.

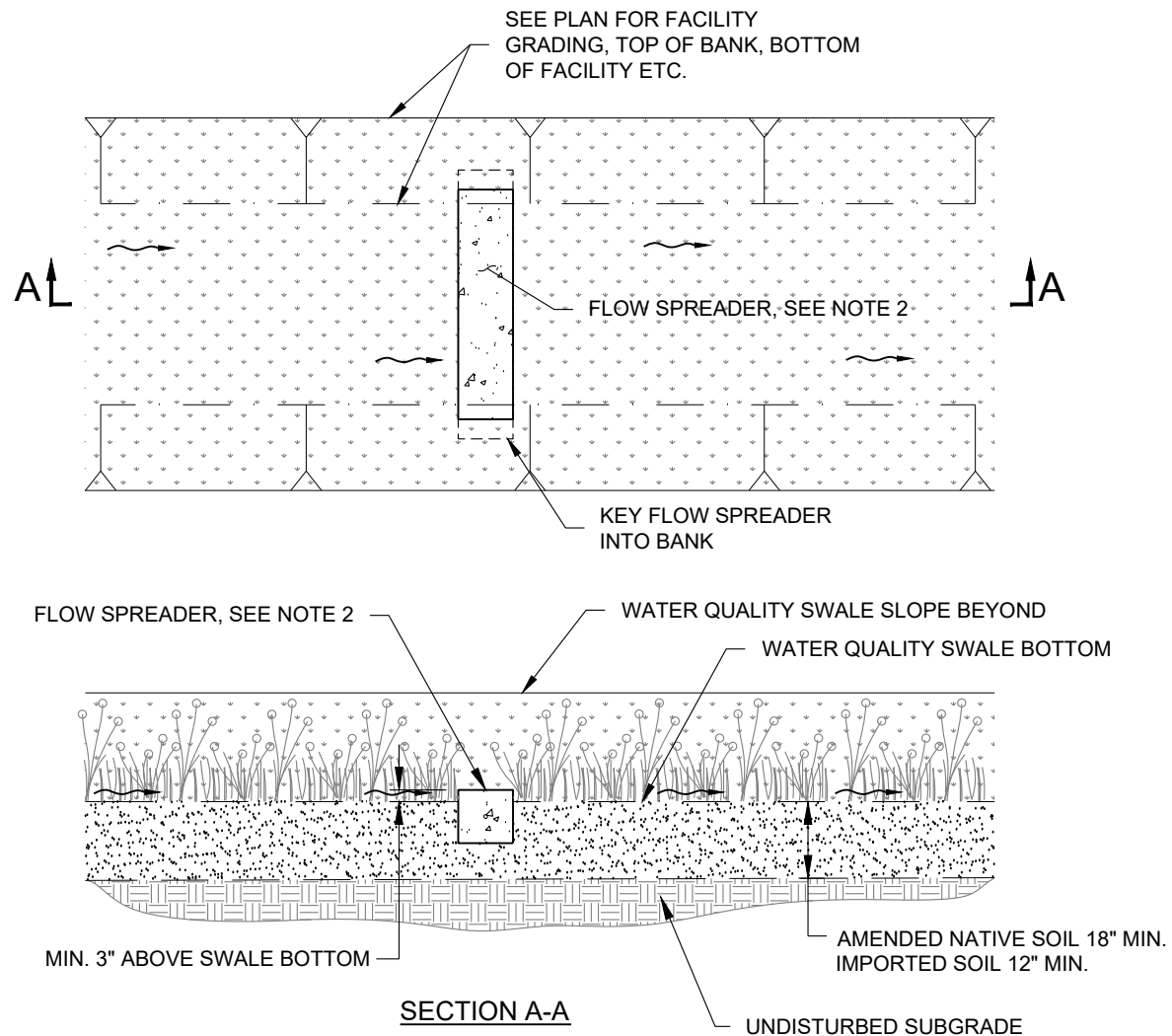

NOTES

1. FLOW SPREADERS SHALL BE INSTALLED WITHIN ALL WATER QUALITY SWALES WHICH HAVE A BOTTOM WIDTH OF FOUR FEET OR GREATER.
2. FLOW SPREADER SHOWN IS AN 8" x 8" CONCRETE SECTION. ALTERNATIVELY, 4" PIT RUN OR SIMILAR NON-ERODIBLE ROCK MAY BE USED.

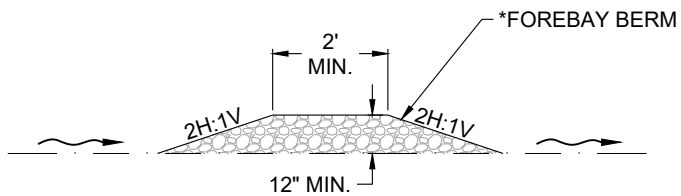
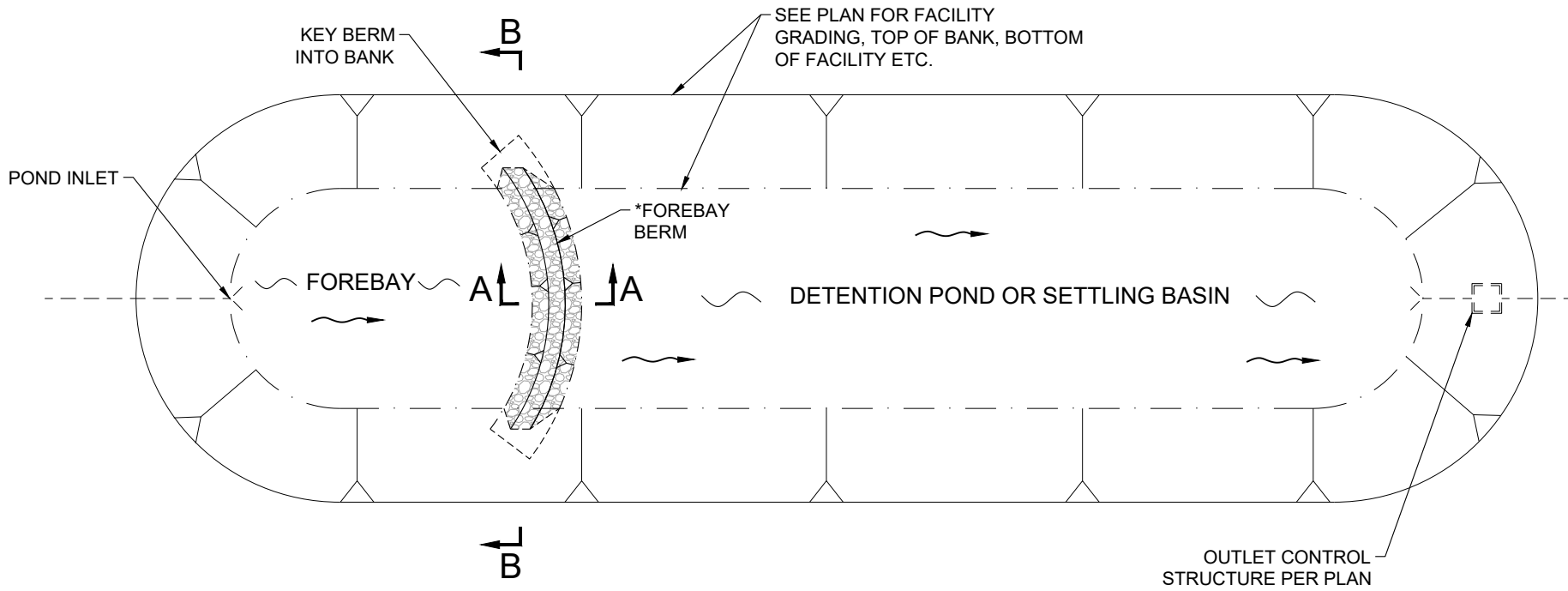

SECTION A-A

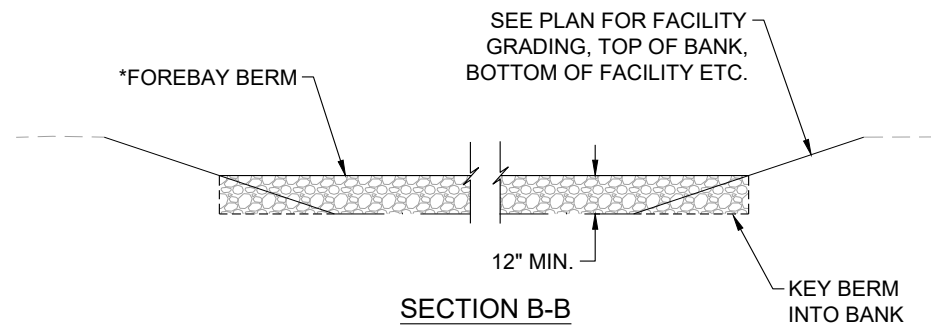

SECTION B-B

*FOREBAY BERMS/DAMS SHALL BE CONSTRUCTED OF NON-ERODIBLE MATERIAL NO SMALLER THAN 4"-Ø OR SIMILAR.

TREE PROTECTION NOTES:

1. EXISTING TREES SHOWN TO REMAIN ARE TO BE PROTECTED DURING CONSTRUCTION. CHAINLINK FENCING (MIN. 4'-0" HEIGHT) SHALL BE INSTALLED AT THE DRIP LINE OF ALL TREES OR TREE GROUPS TO REMAIN. PARKING OF VEHICLES OR PERFORMING WORK WITHIN THESE AREAS OTHER THAN SHOWN ON THE PLAN, WILL NOT BE ALLOWED. THE TREE PROTECTION SHALL REMAIN DURING CONSTRUCTION. OTHER TREE PROTECTION MEASURES SHALL BE IN ACCORDANCE WITH THE CITY'S STANDARDS AND ORDINANCES.
2. DISPOSAL OF ANY WASTE MATERIAL SUCH AS, BUT NOT LIMITED TO, PAINT, ASPHALT, OIL SOLVENTS, CONCRETE, MORTAR, ETC. WITHIN THE CANOPY AREA OF THE EXISTING TREES SHALL NOT BE ALLOWED.
3. NO ATTACHMENTS OR WIRES OF ANY KIND OTHER THAN THOSE OF A PROTECTIVE NATURE, SHALL BE ATTACHED TO ANY TREE.
4. NO FILL OR EXCAVATION OF ANY NATURE SHALL OCCUR WITHIN THE DRIP LINE OF A TREE TO BE PRESERVED, UNLESS THERE IS A SPECIFIED WELL OR RETAINING WALL SHOWN ON THE GRADING PLAN.
5. NO MATERIALS SHALL BE STORED WITHIN THE DRIP LINE AREA OF A TREE TO BE PRESERVED.

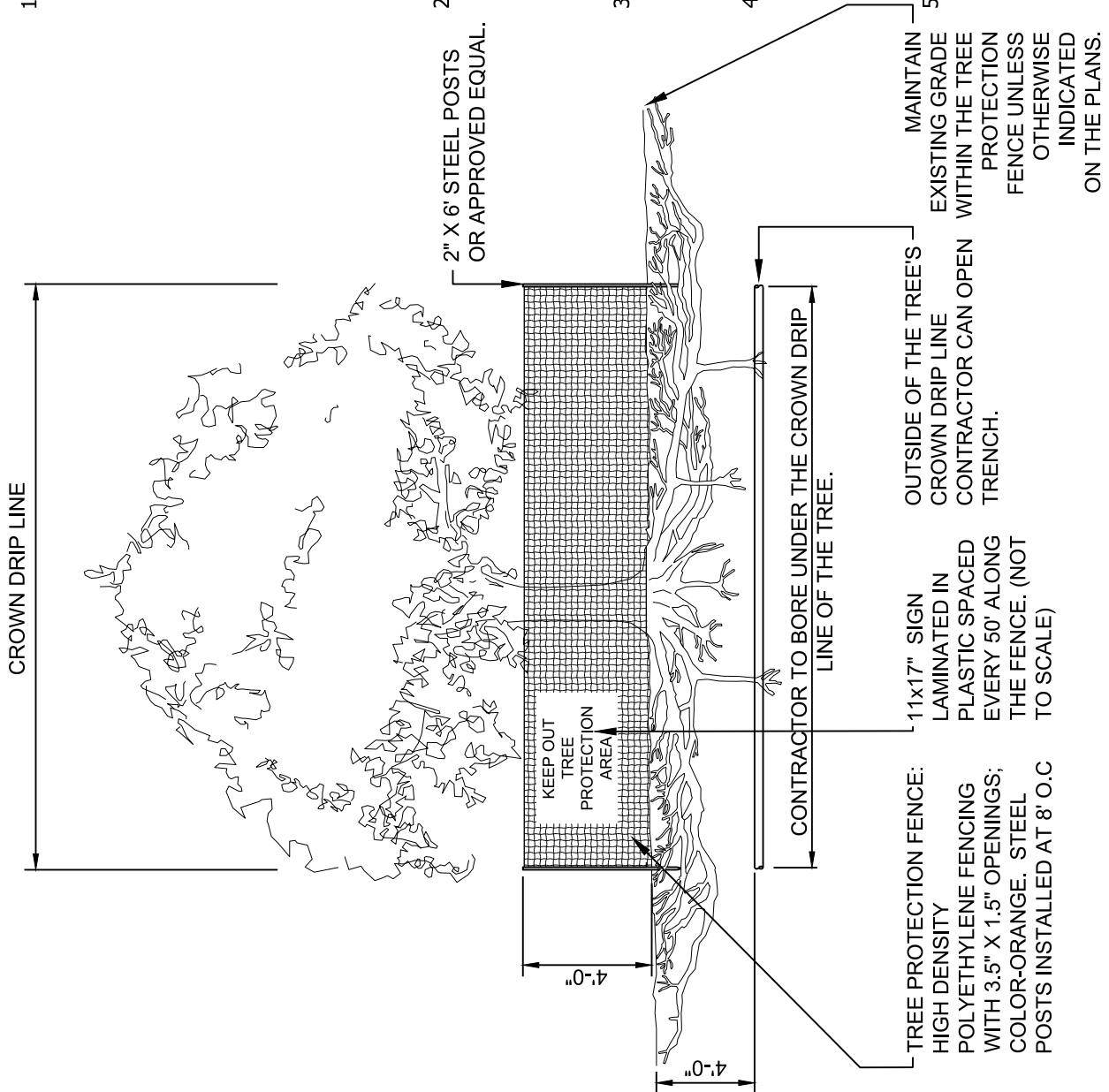

SECTION VIEW

TREE PROTECTION NOTES:

1. EXISTING TREES SHOWN TO REMAIN ARE TO BE PROTECTED DURING CONSTRUCTION. CHAINLINK FENCING (MIN. 4'-0" HEIGHT) SHALL BE INSTALLED AT THE DRIP LINE OF ALL TREES OR TREE GROUPS TO REMAIN. PARKING OF VEHICLES OR PERFORMING WORK WITHIN THESE AREAS OTHER THAN SHOWN ON THE PLAN, WILL NOT BE ALLOWED. THE TREE PROTECTION SHALL REMAIN DURING CONSTRUCTION. OTHER TREE PROTECTION MEASURES SHALL BE IN ACCORDANCE WITH THE CITY'S STANDARDS AND ORDINANCES.
2. DISPOSAL OF ANY WASTE MATERIAL SUCH AS, BUT NOT LIMITED TO, PAINT, ASPHALT, OIL SOLVENTS, CONCRETE, MORTAR, ETC. WITHIN THE CANOPY AREA OF THE EXISTING TREES SHALL NOT BE ALLOWED.
3. NO ATTACHMENTS OR WIRES OF ANY KIND OTHER THAN THOSE OF A PROTECTIVE NATURE, SHALL BE ATTACHED TO ANY TREE.
4. NO FILL OR EXCAVATION OF ANY NATURE SHALL OCCUR WITHIN THE DRIP LINE OF A TREE TO BE PRESERVED, UNLESS THERE IS A SPECIFIED WELL OR RETAINING WALL SHOWN ON THE GRADING PLAN.
5. NO MATERIALS SHALL BE STORED WITHIN THE DRIP LINE AREA OF A TREE TO BE PRESERVED.

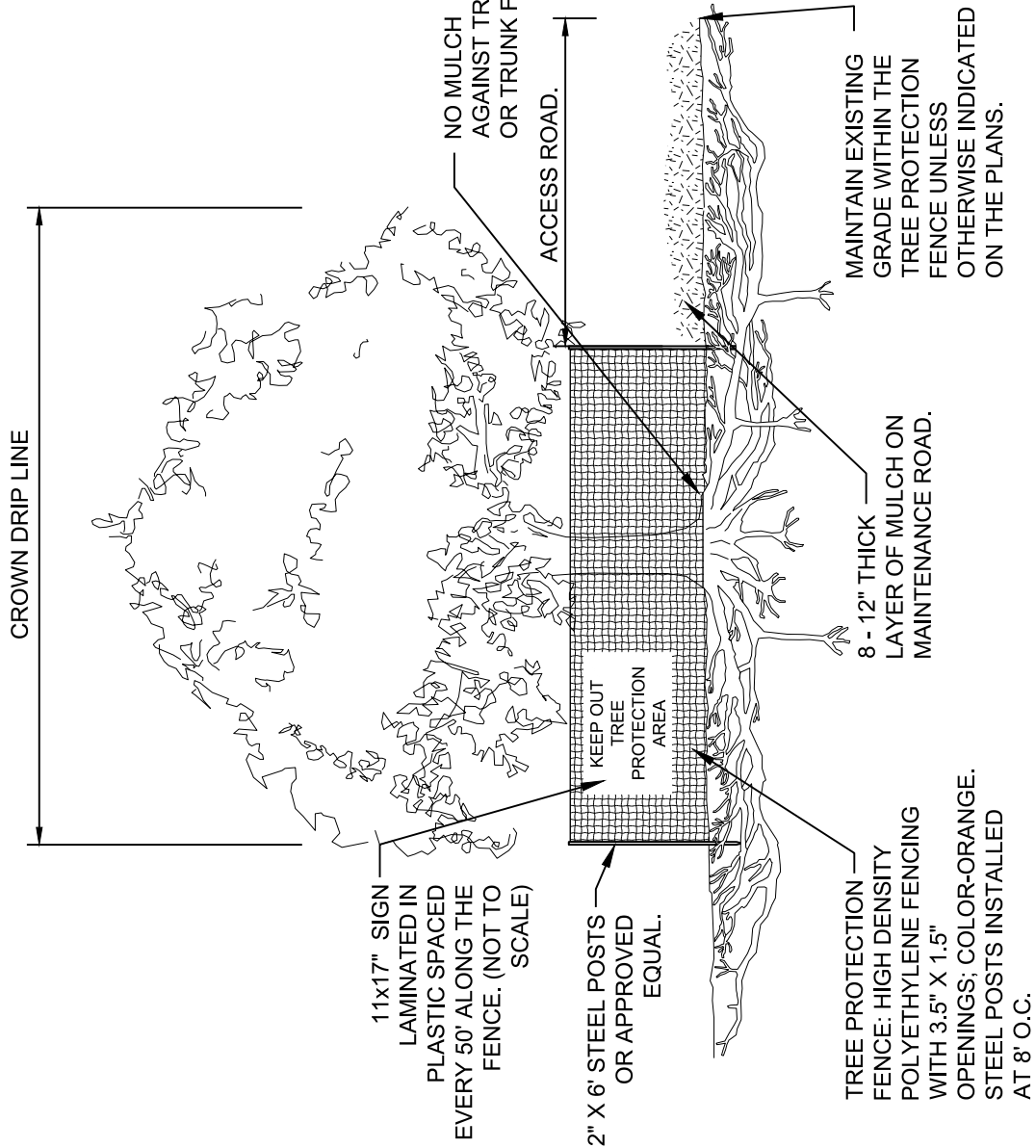

SECTION VIEW

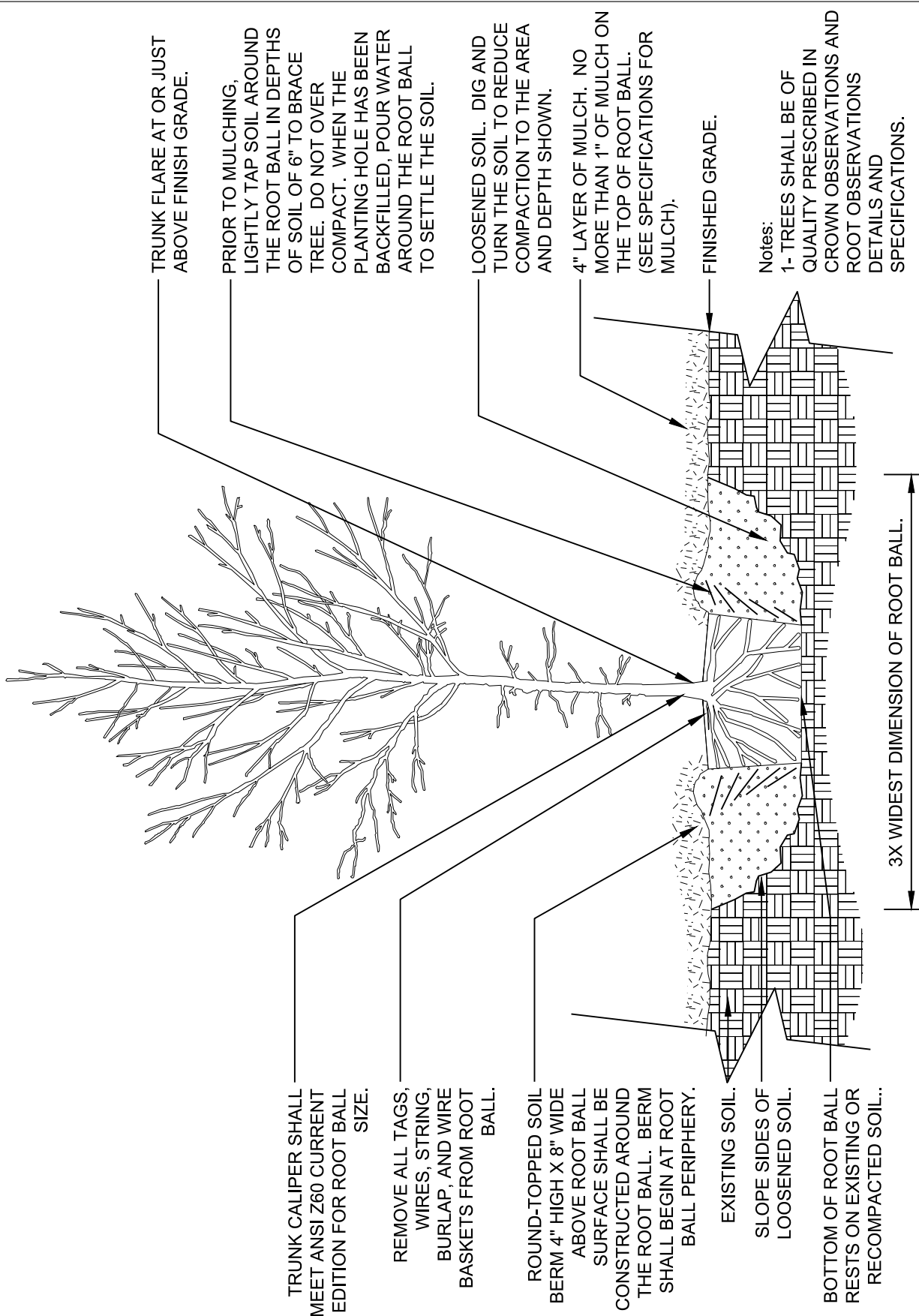

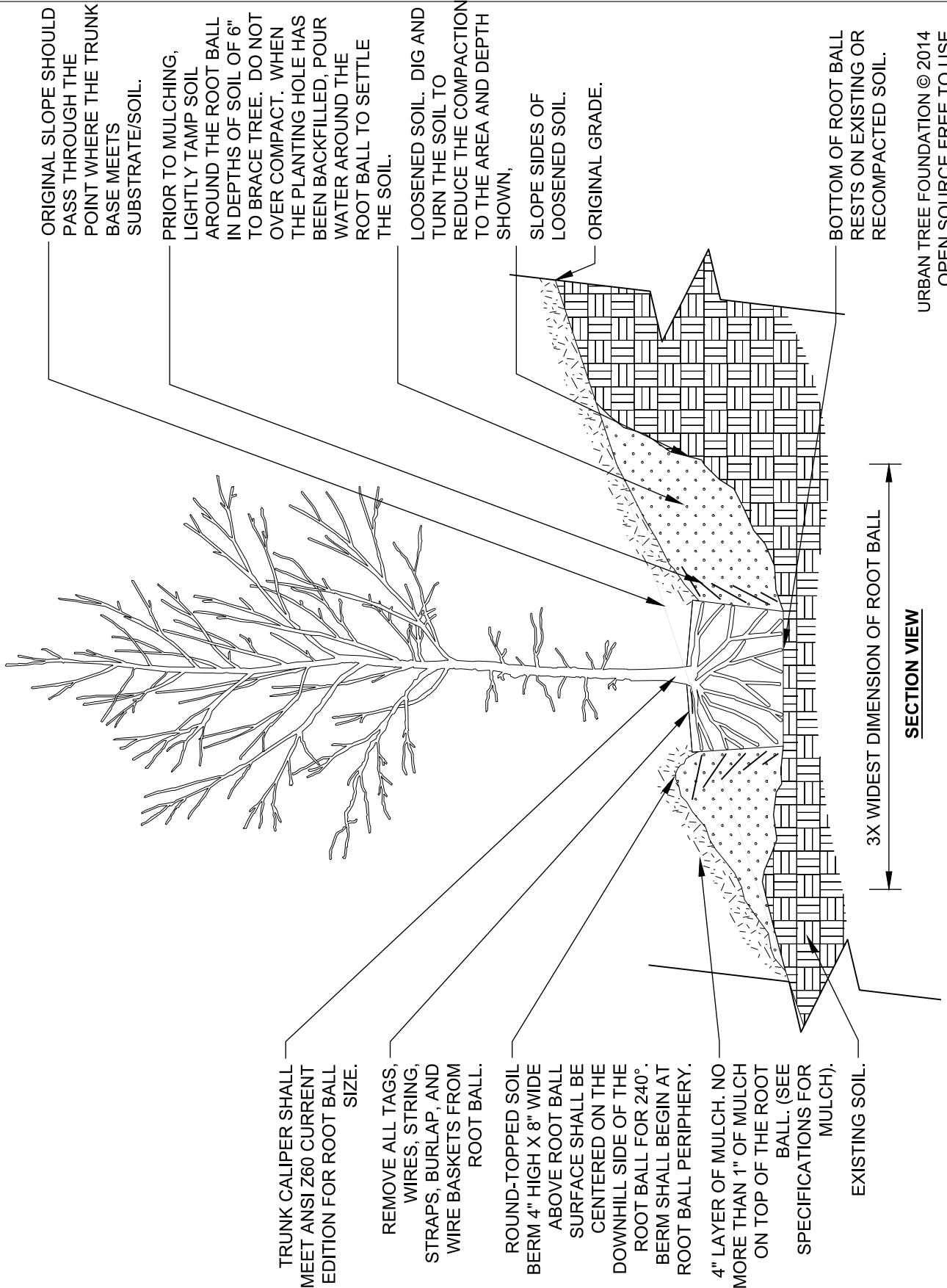

Appendix G: Pre-Approved Proprietary Stormwater Treatment Technologies

When requested, the Stormwater Advisory Team (SWAT) will review proprietary stormwater treatment and detention devices that are not already approved or under review by the Washington Department of Ecology’s Technology Assessment Protocol (TAPE). Per section 5.4 of the Rogue Valley Stormwater Design Manual, data must be collected and submitted to the jurisdiction in accordance with the Technical Guidance Manual for Evaluating Emerging Stormwater Treatment Technologies (TAPE).

The devices listed in Table G-1 have been evaluated by the SWAT and determined to meet the treatment requirements of the Rogue Valley Stormwater Design Manual.

Table G-1. Pre-Approved Proprietary Stormwater Treatment Technologies

Manufacturer	Model	Date Approved by SWAT
Stormtech LLC	Stormtech Isolator Row	2-17-16

Appendix H – Stormwater Operation and Maintenance

Stormwater Operation and Maintenance Plan Templates

O&M Manual Template (fillable pdf)

Section B: RVSS Declaration of Covenants

Medford Declaration of Covenants

Section D: Medford Subdivision O&M Agreement

Section F: SW Facility Inspection and Maintenance Checklists

Instructions for Completing the Stormwater O&M Manual

Delete this page prior to finalizing.

Stormwater management facilities for treatment and detention of stormwater runoff must be maintained in perpetuity. The Operation and Maintenance Manual describes how to maintain the facilities and the Declaration of Covenants contained within the Manual describes legal responsibilities of the property owner. The Stormwater Facilities Operations and Maintenance Manual is to be submitted as separate document from the Stormwater Calculation Report.

Detailed Instructions:

1. Fill in the required information throughout the Operation and Maintenance Manual.
2. Insert the appropriate Inspection and Maintenance Worksheets from the Section F template. Only include the worksheets that apply to this project.
3. Have the property owner sign the Declaration of Covenants in the presence of a notary. The Declaration of Covenants is not required for facilities that will be publicly maintained.
4. Bring the Declaration of Covenants to the approving authority to have them sign the document.
 - a. If receiving approval through RVSS, signed documents may be scanned and emailed to the Stormwater Program Manager, Jennie Morgan at jmorgan@rvss.us.
5. The property owner, or their agent, must take the approved O&M Manual and the fully signed and notarized Declaration of Covenants to the Jackson County recorder office and have the documents recorded on the deed of the property. The address, parking information and hours of operation of the Recorders office is available here: <https://jacksoncountyor.org/clerk/Contact/Recording>.
6. Provide the recorded documents to the approving authority.

Business Name: _____

Map + TL: _____

Business Address: _____

Stormwater Facilities Operation & Maintenance Manual

Date O&M Document Prepared:

Prepared by:

Name: _____

Address: _____

Phone: _____

TABLE OF CONTENTS

Contact Information, Responsible Party Designation	Section A
Declaration of Covenants	Section B
Stormwater Facility Plans	Section C
SW Inspection and Maintenance Checklists and Forms.....	Section D
Proprietary Stormwater Components Operation and Maintenance Information (If Used).....	Section E
DEQ Spill Response Fact Sheet.....	Section F

Stormwater Facilities Operation and Maintenance Manual
Section Descriptions

- A. Contact Information, which is to be updated, and an updated copy of the form provided to the approving authority, whenever information changes, Section A.
- B. A copy of the signed “Declaration of Covenants for the Operation and Maintenance of Stormwater Facilities”, Section B. If the project is located in the City of Medford, a Subdivision Operation and Maintenance Agreement, is required for any portion of the subdivision that drains into a privately maintained stormwater facility. The Subdivision agreement replaces the Declaration of Covenants and must include copies of all recorded easements associated with the stormwater facility including a map of the tax lot(s) showing the location of the easement(s).
- C. A description and diagram showing the location of the stormwater facility(ies) on site and the proposed access route for inspection and maintenance. Approved stormwater facility construction plans, including the plan view and details, in Section C.
- D. The Inspection and Maintenance Worksheets for the specific type of facility(ies) shall be attached as part of the O&M Plan, Section D.
- E. For proprietary stormwater systems, include the manufacturer’s maintenance documents, Section E.
- F. The DEQ Fact Sheet for responding to a spill, Section F.

Section A

Contact Information

Contact Information

Print or type the following information:

Project Name _____ Building Permit # _____

Site Information: Address _____

City/State/Zip _____ Map and Tax Lot(s) _____

Legal Owner Information

Name(s) _____

Address (mailing) _____ City/State/Zip _____

Phone _____ Email _____

Responsible Party for Maintenance

Property Owner Property Management Company Homeowner's Association Tenant

Other _____

Contact Information for Responsible Party

Contact Name/Position _____

Contact Organization _____

Phone _____ Email _____

EMERGENCY CONTACT

Contact Name/Position _____

Phone _____ Email _____

Stormwater Facility Type

List each stormwater treatment and detention facility associated with this project, if a proprietary facility provide the manufacturer and model.

Responsible Party Designation Form

This form to be used if designating a third party as responsible for operation and maintenance.

The undersigned, Property Owner(s) _____,
owners of property with a site address of: _____,
Jackson County, Oregon, do hereby declare that as of _____, 20____,
_____ will be the responsible party for
operating and maintaining the stormwater management facility described in the Declaration of
Covenants for the Operation and Maintenance of Stormwater Facilities in accordance with all
measures prescribed in the Covenants. They will remain the responsible party until the property owner
signs a new Responsible Party Designation Form with a new entity. Nothing herein in any way
alleviates or diminishes Property Owner's primary and ultimate responsibility and liability to comply
with RVSS ordinances and regulations and to perform as required per the Declaration of Covenants
executed the _____ day of _____, 20____.

Owner Printed Name

Responsible Party Printed Name

Owner Signature

Responsible Party Signature

Section B

Declaration of Covenants / Subdivision Agreement

Section C

Stormwater Facility Plans

Section D

STORMWATER MAINTENANCE CHECKLISTS AND RECORD

Inspection and Maintenance Action Checklists

Stormwater Facility Maintenance Record

Section E

Proprietary Stormwater Components Operation and Maintenance Information (If Used)

Section F

Spill Response Plan

Declaration of Covenants for the Operation & Maintenance of Stormwater Facilities For

Declaration of covenants affecting the real property(ies) described in Exhibit “A” (legal description) or by Instrument Number: _____, also known as: _____
_____ (Map & Tax Lot), with a site address of: _____
_____, (hereinafter referred to as the “property”), for the express purpose of causing the owners of said property to be subject to performing the operation and maintenance of the stormwater facility located on the property:

NOW THEREFORE, the undersigned, _____,
owners of said property, do hereby declare that they, their heirs, successors and assigns, will manage, operate, and maintain the stormwater facility including any catch basins, piping, and treatment and detention facilities described as

_____ (hereinafter collectively referred to as “Facility”), as prescribed below:

1. This Covenant, and all components of the Operation and Maintenance Manual (hereafter referred to as O&M Manual) that it is contained within, shall remain in full force and effect unless canceled or modified with the written consent of RVSS and the property owner/owners.
2. The property owner/owners shall keep a copy of the jurisdiction approved Stormwater Facilities Operation and Maintenance Manual, dated _____, available on the premises,. These shall be made available to RVSS staff upon request.
3. The property owner/owners agree to contact RVSS with updated names, addresses, and phone numbers for owner’s, and responsible parties should the information on the Contact Form, Section A, change.
4. The property owner/owners shall inspect and maintain the approved Facility, and easements associated with the Facility, in accordance with the approved Inspection and Maintenance Worksheets within the O&M Manual to ensure it is functioning properly.
5. Modifications of physical features within the Facility shall not be made by property owner/owners or their without receiving prior written authorization from RVSS.

6. The property owner/owners shall keep records of Facility system inspections and maintenance for five years from the date of each inspection. Records shall note inspection dates, any conditions requiring maintenance actions, and maintenance conducted. Records shall be made available to RVSS staff upon request at no cost to RVSS.
7. RVSS staff shall have the right to enter upon owner's property, using the maintenance access routes specified in the O&M Manual, for the purpose of inspecting the Facility subject to regulation under Chapter 4.05.120 of RVSS' code, as often as may be necessary to determine compliance.
8. If RVSS determines that the Facility or any part thereof is not functioning properly, the owner will either take corrective actions, or will submit a plan of action that is approved within 14 calendar days, unless other arrangements are made with RVSS.
9. If Owner fails or refuses to timely and/or faithfully perform any obligation required of Owner as set forth herein, RVSS may make or perform such maintenance, repair, or other work or other task and charge the actual costs thereof to Owner. Such expenditures by RVSS shall be reimbursed by Owner on demand together with interest at the rate of 12% per annum from the date of expenditure by RVSS.
10. If all, or any part, of the Facility is located within a Public Utility Easement (PUE.), the property owner/owners shall bear all responsibility and cost to remove and replace any portion or affected portion of the Facility located within any PUE located on the subject property at such time when the benefitting agency deems it necessary for access, maintenance and/or other activities as permitted by the PUE.
11. In the event suit, action, or other proceeding is instituted to enforce or interpret this Agreement, the prevailing party shall be entitled to recover from the non-prevailing party the prevailing party's costs, disbursements and attorney fees incurred through trial and upon any appeal therefrom.

The above covenants shall run with the land, be enforceable by the Rogue Valley Sewer Services, and shall be binding upon the property owner/owners, their heirs, successors, and assigns.

IN WITNESS WHEREOF, the property owner(s), signed this _____ day of _____, 20____.

(Owner Printed Name)

(Owner Signature)

STATE OF _____)

County of _____) ss:

_____, 20____

Personally appeared, the above-named _____, and acknowledged the foregoing instrument to be a voluntary act. Before me:

Notary Public for Oregon

My Commission expires: _____

THE FOREGOING IS HEREBY ACCEPTED BY ROGUE VALLEY SEWER SERVICES,
138 W Vilas
Central Point, OR 97502

By Carl Tappert, General Manager

STATE OF OREGON)

County of Jackson) ss:

Date: _____

Personally appeared before me the above named Carl Tappert, General Manager, Rogue Valley Sewer Services and acknowledged the foregoing instrument to be his voluntary act and deed.

Notary Public for Oregon
My Commission Expires: _____

Exhibit "A"

Legal Description of Property

STORMWATER MAINTENANCE CHECKLISTS AND RECORD

Inspection and Maintenance Action Checklists

Stormwater Facility Maintenance Record

STORMWATER FACILITY INSPECTION AND MAINTENANCE ACTION CHECKLISTS

Stormwater Facility Design Functions: (Boxes to be checked by designer only.)

The Stormwater Facilities at this site are designed to perform specific functions indicated below, and must be maintained to perform those functions in perpetuity. Changes to the Facility that would alter its designed function require consent from the local approving jurisdiction. Check all that apply:

- Infiltration (All Retention BMP's): Runoff is captured and held only leaving the facility through infiltration into the ground, evaporation or absorption by vegetation.
 - Does the infiltration facility design require 90% vegetation coverage? yes no
 - If Yes, the Inspection and Maintenance Checklist for Vegetated Facilities must be included.
 - If No, the Inspection and Maintenance Checklist for Vegetated Facilities is not required.
- Flow-through Treatment (Water Quality Swale BMP and Dispersion BMPs): Runoff is captured in the facility and flows through vegetation and/or soils before flowing downstream.
 - Does the facility incorporate a Water Quality Swale or Vegetated Filter Strip? yes no
 - If Yes, the Inspection and Maintenance Checklist for Vegetated Facilities must be included.
 - If No, the Inspection and Maintenance Checklist for Vegetated Facilities is not required.
- Filtration Treatment (Soil Filtration BMP and Vegetated Roof): Runoff is captured in the facility and is filtered through a soil substrate before being captured in and discharged through an underdrain.
- Settlement for Treatment (Water Quality Settling Basin BMP): Runoff is captured and held for a specified amount of time to allow solids to settle before being slowly released downstream.
- Proprietary Treatment BMP: Runoff is captured in a proprietary treatment device and is treated as specified by the manufacturer. The manufacturer's maintenance documents must be included.
- Peak Flow Control (Detention BMP): Peak flow from a 10 year event is captured, held, and released at a rate no greater than the pre-developed peak flow rate.

Inspection and Maintenance:

The checklists indicate recommended conditions to look for and actions to take should those conditions exist. They can assist with planning, scheduling, staffing, and budgeting for operation and maintenance of the stormwater facility.

Inspections: At least one inspection per year is required, some items require inspection during a storm event, refer to the Inspection Checklist. Document the date of inspection on the Inspection Checklist and list any maintenance that is needed.

Maintenance Records: Maintenance records must be kept on all stormwater facilities. Trash removal is required to be done, but not required to be documented. All other items listed as required maintenance items must be documented. An example Maintenance Record is provided in this packet. On the Maintenance Record, list the issue to be addressed and the date action was taken and describe the action taken. The individual who inspects and approves the completed work should initial the 'Work approved by' box. Invoices and work orders for supplies and hiring contractors to complete work should be kept on file. The property owner/owners shall keep records of facility system inspections and maintenance for five years from the date of each inspection. Records shall be made available to jurisdictional authority upon request, at no cost.

Manufactured Treatment Structures: These structures will have maintenance requirements from the manufacturer that are included in this packet.

Pesticides: Pesticides (which includes herbicides, insecticides, fungicides), are prohibited within stormwater facilities due to the potential to contaminate downstream waters. Utilize integrated pest management to assess and address pest issues.

Fertilizers: Avoid the use of fertilizers in stormwater facilities. Instead, mulch plants with shredded wood chips or coarse compost. Mulch must be dye, pesticide and weed free.

Pollution Prevention: Best Management Practices must be implemented on all sites to prevent stormwater contamination. Spills should be cleaned up following best management practices and should never be washed into a stormwater treatment facility. If a spill occurs into the stormwater facility, contact the approving jurisdiction immediately. Document time and date, weather conditions, what spilled, approximately how much, and any corrective action taken. If possible, block the inlet to the stormwater facility to prevent the material from flowing in. If the material reaches the stormwater facility, soils and vegetation may have to be replaced.

Inspection and Maintenance Action Checklist			Pervious Pavement	
PROHIBITIONS				
<ul style="list-style-type: none"> No stockpiles of soil/mulch/debris may be staged on the pervious surface and grass/leaves/debris should not be blown onto the surface. Ensure landscape contractors understand that the surface is permeable. Inform them that they cannot stage or blow material onto the surface. Do not seal coat the pervious surface or overlay with an impervious surface. Repair raveling or settling per manufacturer specification. 50sf or less of damage may be patched with conventional asphalt, up to 10% of the entire pervious surface. Snow removal with salt is prohibited. Use salt-free deicers only. Do not apply deicers to concrete <1 year old. Always plow with the blade one inch above the surface. 				
Required Actions				
Surface cleaning		<ul style="list-style-type: none"> Vacuum or dry sweep at least twice a year Or, pressure wash at a right angle to the pavement 		
Conditions to Check for	Action	Required/Suggested	Inspection Date	Maintenance Needed (if none, state none needed)
Erosion from landscape areas onto pervious paving	Implement temporary erosion prevention and sediment control and a permanent fix for the erosion issue(s).	Required		
Reduced infiltration	Must inspect during a storm event. If storms are not infiltrating, contact the jurisdiction.	Required		
Weed and moss growth over 10% of area or more	Mechanically remove during the dry season. Avoid mossicides and herbicides.	Required		
Trash and Leaves	Pick up trash, blow or sweep leaves. Remove and dispose.	Required		
Signage describing Pervious Pavement in place	If a sign was specified on the plans, ensure sign is visible and legible.	Required		
Aggregate loss, potholes, cracks	Repair per manufacturer specification, 50sf or less of damage may be patched with conventional asphalt, up to 10% of the entire pervious surface.	Suggested		
Settling of pavers or loss of paver filling.	Reset pavers and replace missing fill material per original design.	Suggested		

*The Pervious Pavement Checklist applies and must be included for the following BMPs:

- Pervious Surface Retention BMP (pervious asphalt, pervious concrete, pervious pavers)

Inspection and Maintenance Action Checklist		Flexible Paving Systems and Pervious Gravel Surfaces		
PROHIBITIONS				
<ul style="list-style-type: none"> • Pesticide use in stormwater facilities is prohibited. • No Stockpiles may be located on the flexible paving system or pervious gravel. Ensure landscape contractors understand that the surface is permeable. Inform them that they cannot stage material on the surface or blow grass/leaves/etc. onto the surface. 				
Conditions to Check For	Action	Required/ Suggested	Inspection Date	Maintenance Needed (if none, state none needed)
Erosion from landscape areas onto pervious paving	Implement temporary erosion prevention and sediment control and a permanent fix for the erosion issue(s).	Required		
Reduced infiltration	If storms are not infiltrating, contact the jurisdiction.	Required		
Trash and Leaves	Pick up trash, blow or sweep leaves. Remove and dispose.	Required		
Signage describing Pervious Pavement in place	If a sign was specified on the plans, ensure sign is visible and legible.	Required		
Aggregate loss	Replace with aggregate per original design.	Suggested		
If vegetation is required to function and coverage is poor, Inspect for bare soil, exposed rings, ruts poorly growing grass from too much shade, and thatch.	Reseed, verify irrigation system is functioning. Avoid aeration since this equipment will damage the flexible system.	Suggested		
Maintenance Specific to Pervious Gravel				
Reduced Infiltration	Remove the first few inches of rock and either wash in an area that does not drain to the stormwater system and replace, or replace with new washed rock matching the original aggregate specification.	Suggested		

*The Flexible Paving Systems and Pervious Gravel Surfaces Checklist applies and must be included for facilities that incorporate the following BMPs:

- **Pervious Surface Retention BMP (Flexible Paving Systems or Pervious Gravel Surfaces)**

Inspection and Maintenance Action Checklist		Vegetated Facilities*		
PROHIBITIONS				
<ul style="list-style-type: none"> • Pesticide use in stormwater facilities is prohibited. • Removal of vegetation to less than 90% surface cover is prohibited. 				
Conditions to Check For	Actions	Required/ Suggested	Inspection Date	Maintenance Needed (if none, state none needed)
Vegetation covers < 90% of facility surface	<p>Possible Ways to achieve 90% vegetation cover:</p> <ul style="list-style-type: none"> • Determine if irrigation system is functioning properly and fix if needed. • Have a soil fertility test done to determine if nutrient addition is needed, if so add compost. • Add mulch around plantings. • Revegetate following approved landscape plan to achieve at least 90% coverage. 	Required		
Sediment washing out of facility	If sediment accumulated in the facility bottom is washing out, excavate and remove. Assess side slopes and bottom for erosion, fill in any eroded areas with approved soil mix and cover with mulch or vegetation.	Required		
Channelization in Water Quality Swale. Flow has become channelized and does not spread across bottom width of swale.	<ul style="list-style-type: none"> • Recontour to design width and elevation. • Replant vegetation to cover the entire facility bottom. • Consider installing a flow spreader device. Contact the approving jurisdiction for advice on flow spreader installation. 	Required		
Clogged or damaged inlets, outlets, pipes, check dams, perforated pipes or underdrains; if interfering with facility function	<ul style="list-style-type: none"> • Remove sediment and debris to maintain adequate conveyance. • Repair or replace damaged pipes, inlets, outlets to match approved design. 	Required		
Energy dissipator(s) damaged/missing at inlets and outlets (where specified)**	<p>If rock is washing out, evaluate need to replace with larger rock.</p> <p>If missing, replace rock with size and at depth specified.</p>	Required		
Check Dams damaged (if installed)	Maintain design number, spacing and elevation, of check dams.	Required		

Inspection and Maintenance Action Checklist		Vegetated Facilities*		
Ponding for more than six days	In swales, check that outflow is not blocked by vegetation or debris. In infiltration facilities, remove the clogged soil then rake, till or amend the soil with the approved soil mix. Contact the approving jurisdiction to discuss soil replacement if this is insufficient.	Required		
Trash and debris.	Remove and dispose.	Required		
Odor, sludge, or color. Presence of any chemical pollutants.	Notify appropriate jurisdiction to investigate. Remove contaminant by appropriate methods and dispose of as directed by hazardous waste protocols.	Required		
Access to facility is restricted	<ul style="list-style-type: none"> Public facilities must have unrestricted all weather access to all inlets, pipe openings, flow control structures Private facilities must have unrestricted access that is traversable by maintenance vehicles during dry months. 	Required		
Vegetation blocks sight lines, inlets, outlets.	<ul style="list-style-type: none"> Prune vegetation that blocks sight lines, inlets, outlets. Do not string trim grasses, sedges or rushes. Remove dead vegetation before it covers 10% of the surface area. Facilities seeded with low-mow or no-mow seed mix, should be cut a maximum of three to four times a year to reduce fire risk. In infiltration facilities, utilize a weed whacker rather than a mower to reduce compaction of the facility soils. Maintain vegetation at 6 inches or taller in swales. 	Suggested		
Erosion within facility. Check inlets, slopes, energy dissipators and facility bottom.	Any erosion deeper than two inches should be addressed. Determine cause of erosion and eliminate. Refill eroded channels with approved soil media and replant. If possible, redirect flows temporarily and apply appropriate	Suggested		

Inspection and Maintenance Action Checklist		Vegetated Facilities*		
	temporary erosion control best management practices.			

*The Vegetated Facilities Checklist applies and must be included for stormwater facilities that incorporate the following BMPs:

- **Ponded Retention BMP with Vegetation:** eg. rain gardens, stormwater planters and retention ponds designed with 90% vegetation coverage
- **Water Quality Swale BMP**
- **Dispersion BMP:** Vegetated Filter Strips only

****Energy Dissipators:** Typically located below an inlet to a stormwater facility and made of rip-rap, concrete, or a proprietary structure. They prevent scouring of the stormwater facility substrate.

Inspection and Maintenance Action Checklist		Unvegetated Surface Facilities*		
PROHIBITIONS				
<ul style="list-style-type: none"> Pesticide use in stormwater facilities is prohibited. 				
Conditions to Check For	Action	Required/ Suggested	Inspection Date	Maintenance Needed (if none, state none needed)
Sediment washing out of facility	If sediment accumulated in the facility bottom is washing out, excavate and remove. Assess side slopes and bottom for erosion, fill in any eroded areas with approved soil mix and cover with mulch or vegetation.	Required		
Clogged or damaged inlets, outlets, pipes, perforated pipes or underdrains; If interfering with facility function	Remove sediment and debris to maintain adequate conveyance. Repair or replace damaged pipes, inlets, and outlets to match approved design.	Required		
Energy dissipator(s) damaged/missing at inlets and outlets (where specified)**	If rock is washing out, evaluate need to replace with larger rock. If missing, replace rock with size and at depth specified.	Required		
Ponding for more than six days	In infiltration facilities, remove the clogged soil then rake, till or amend the soil with the approved soil mix. Contact the approving jurisdiction to discuss soil replacement if this is insufficient.	Required		
Trash and debris.	Remove and dispose.	Required		
Odor, sludge, or color. Presence of any chemical pollutants.	Notify appropriate jurisdiction to investigate. Remove contaminant by appropriate methods and dispose of as directed by hazardous waste protocols.	Required		
Liner (if installed) torn or punctured	Repair or replace as necessary per manufacturer specification.	Required		
Access to facility is restricted	<ul style="list-style-type: none"> Public facilities must have unrestricted all weather access to all inlets, pipe openings, flow control structures Private facilities must have unrestricted access that is traversable by maintenance vehicles during dry months. 	Required		
Erosion within facility. Check inlets, slopes, energy dissipators and facility bottom.	Any erosion deeper than two inches should be addressed. Determine cause of erosion and eliminate. Refill eroded channels with approved soil media. If possible, redirect flows temporarily and apply	Suggested		

Inspection and Maintenance Action Checklist		Unvegetated Surface Facilities*		
	appropriate temporary erosion control best management practices.			

*The Unvegetated Surface Facilities Checklist applies and must be included for facilities that incorporate the following BMPs:

- **Ponded Retention BMP** without Vegetation: eg. rain gardens, stormwater planters and retention ponds designed without 90% vegetation coverage.
- **Soil Filtration BMP**: eg. rain gardens and stormwater planters designed as filtration facilities with underdrains.

****Energy Dissipators**: Typically located below an inlet to a stormwater facility and made of rip-rap, concrete, or a proprietary structure. They prevent scouring of the stormwater facility substrate.

Inspection and Maintenance Action Checklist		Detention & Settling Basins*		
PROHIBITIONS				
<ul style="list-style-type: none"> Pesticide use is prohibited in stormwater facilities. 				
Conditions to Check For	Action	Required/Suggested	Inspection Date	Maintenance Needed (if none, state none needed)
Clogged or damaged inlets, outlets, pipes, perforated pipes, underdrains or check dams; If interfering with facility function	Remove sediment and debris to maintain adequate conveyance. Repair or replace damaged pipes, inlets, and outlets to match approved design.	Required		
Sediment washing out of facility	If sediment accumulated in the facility bottom is washing out, excavate and remove the accumulated sediment. Assess side slopes and bottom for erosion, and stabilize to prevent erosion. If erosion persists, seek technical assistance.	Required		
Energy dissipator(s) damaged/missing at inlets and outlets (where specified)**	Replace rock of size and at depth specified. Evaluate need to replace with larger rock. Repair eroded areas as necessary. Determine cause of rock movement and replace with same size rock or larger as necessary.	Required		
Sediment accumulation exceeding 20 percent of the forebay depth or 4 inches, whichever is less.	Remove sediment.	Required		
Overflow berms or spillways exposed and either actively eroding or vulnerable to erosion.	Replace armoring or replant as directed in design plans and specifications.	Required		
Trash and debris.	Remove and dispose.	Required		
Trash rack or bar screen missing or more than 25% covered	Remove debris and dispose of waste. Repair or replace rack as necessary.	Required		
Odor, sludge, or unusual color. Presence of any chemical pollutants.	Notify appropriate jurisdiction to investigate. Remove contaminant by appropriate methods and dispose of as directed by hazardous waste protocols.	Required		
Access to facility is restricted	<ul style="list-style-type: none"> Public facilities must have unrestricted all weather access to all inlets, pipe openings, flow control structures Private facilities must have unrestricted access that is traversable by maintenance vehicles during dry months. 	Required		

Inspection and Maintenance Action Checklist		Detention & Settling Basins*		
Vegetation blocks sight lines, inlets, outlets.	Prune vegetation that blocks sight lines, inlets, outlets. Do not string trim grasses, sedges or rushes.	Suggested		
Erosion within facility. Check inlets, slopes, energy dissipators and facility bottom.	Determine cause of erosion and eliminate and stabilize to prevent erosion. If possible, redirect flows temporarily and apply appropriate temporary erosion control best management practices.	Suggested		

*The Detention & Settling Basins Checklist applies and must be included for facilities that incorporate the following BMPs:

- Water Quality Settling Basin BMP
- Detention BMP (Flow Control)

****Energy Dissipators:** Typically located below an inlet to a stormwater facility and made of rip-rap, concrete, or a proprietary structure. They prevent scouring of the stormwater facility substrate.

Inspection and Maintenance Action Checklist		Disconnected Downspouts		
PROHIBITIONS				
<ul style="list-style-type: none"> Discharging runoff on another property is not allowed. 				
<ul style="list-style-type: none"> No impervious surfaces may be added within the dispersion area. 				
<ul style="list-style-type: none"> Directly connecting downspouts to the sanitary or stormwater system or directing runoff to flow into the stormwater system is prohibited. 				
Conditions to Check For	Action	Required/ Suggested	Inspection Date	Maintenance Needed (if none, state none needed)
Damaged or missing pipes or downspout extension	Ensure extension ends a minimum of 10 ft from structure. Repair and replace as needed.	Required		
Clogged or blocked pipes, elbows or downspout extension	Clear pipes and elbows of debris to maintain at least adequate capacity. Clear any accumulated debris at downspout extension or splash block. Verify that dispersion area is not encroached upon by other structures.	Required		
Erosion at outlet	Check that splash blocks or energy dissipation is in place and functional. Repair eroded areas as necessary. Repair or replace splash blocks. If rock energy dissipation has moved, determine cause and replace with same size rock or larger as necessary.	Required		
Vegetation blocks downspout extension or visibility.	Prune vegetation that blocks downspout extension or visibility of traffic.	Suggested		

*The Disconnected Downspouts Checklist applies and must be included for facilities that incorporate the following BMPs:

- Dispersion BMP: Disconnected Downspouts

****Energy Dissipation:** Typically located below an inlet to a stormwater facility and made of rip-rap, concrete, or a proprietary structure. Prevents scouring of the stormwater facility substrate.

Inspection and Maintenance Action Checklist		Vegetated Filter Strips*		
Prohibited Actions				
<ul style="list-style-type: none"> • Pesticide use within stormwater facilities. • Removal of vegetation to less than 90% surface cover. 				
Conditions to Check For	Action	Required/Suggested	Inspection Date	Maintenance Needed (if none, state none needed)
Channelization. Flow has become channelized and does not spread over entire facility.	<ul style="list-style-type: none"> • Check condition of flow spreader, repair or replace as needed to evenly disperse flow. • If needed, re-contour facility to design elevation and replant vegetation to evenly cover facility. 	Required		
Vegetation covers < 90% of facility bottom	Possible Ways to achieve 90% vegetation cover: <ul style="list-style-type: none"> • Determine if irrigation system is functioning properly. • Have a soil fertility test done to determine if nutrient addition is needed, if so add compost. • Add mulch around plantings. • Revegetate following approved landscape plan to achieve at least 90% coverage. 	Required		
Trash and debris.	Remove and dispose.	Required		
Access to facility is restricted	<ul style="list-style-type: none"> • Public facilities must have unrestricted all weather access to all inlets, pipe openings, flow control structures • Private facilities must have unrestricted access that is traversable by maintenance vehicles during dry months. 	Required		
Access to facility is restricted	<ul style="list-style-type: none"> • Public facilities must have unrestricted all weather access to all inlets, pipe openings, flow control structures • Private facilities must have unrestricted access that is traversable by maintenance vehicles during dry months. 	Required		
Erosion within facility.	<ul style="list-style-type: none"> • Any erosion deeper than two inches should be addressed. Determine cause of erosion and eliminate. Refill eroded channels with approved soil media and replant. If possible, redirect flows temporarily and apply appropriate temporary erosion control best management practices. 	Required		

Inspection and Maintenance Action Checklist		Vegetated Filter Strips*		
Vegetation blocks sight lines, inflow, outlets.	<ul style="list-style-type: none"> • Prune vegetation that blocks sight lines, inflow, outlets. Do not string trim grasses, sedges or rushes. • Remove dead vegetation before it covers 10% of the surface area. • Facilities seeded with low-mow or no-mow seed mix, should be cut as needed to reduce fire risk. Maintain vegetation at 6 inches or taller. 	Suggested		

*The Vegetated Filter Strips Checklist applies and must be included for facilities that incorporate the following BMPs:

- Dispersion BMP: Vegetated Filter Strips

Inspection and Maintenance Action Checklist		Underground Structures*		
Conditions to Check For	Action	Required/ Suggested	Inspection Date	Maintenance Needed (if none, state none needed)
Sediment and debris exceeding 15% of the structure height or 6" in depth, whichever is less.	Sediment should be removed and disposed of properly at a landfill or approved facility. This may require contracting with a plumbing company that has a vacuum truck. For proprietary structures, follow the manufacturer's maintenance guidelines.	Required		
Plugged or blocked catch basins, pipes, underdrains, silt traps, inlets, perforated pipes, air vents.	Remove sediment and debris to maintain adequate conveyance at all times.	Required		
Cracks in joints between tank or pipe sections that leak soil into the facility.	Manually seal all cracks with appropriate grout material.	Required		
Underground facility structurally deficient or restricting flow.	Repair or replace structure to design.	Required		
Soakage trench surface clogged	<ul style="list-style-type: none"> If water infiltrates through surface, remove and clean rock on the surface. Replace the geotextile fabric on the top, being careful not to damage the fabric on the sides. Place the cleaned rock back over the geotextile fabric. Dispose of sediment in trash destined for the landfill. Sweeping regularly will reduce the likelihood of clogging. High traffic areas will clog faster than low traffic areas. 	Required		
Missing an operable manhole cover.	Replace cover or repair and reinstall.	Required		
Cleanout shear gate damaged, rusted, leaking or missing. Gate cannot be adjusted by one person. Chain or rod missing or damaged	Repair or replace to meet design standards. Repair, lubricate, or replace gate as necessary. Repair or replace chain or rod as necessary.	Required		
Odor, sludge, or unusual color. Presence of any chemical pollutants.	Notify appropriate jurisdiction to investigate. Remove contaminant by appropriate methods and dispose of as directed by hazardous waste protocols.	Required		
Access to facility is restricted	<ul style="list-style-type: none"> Public facilities must have unrestricted all weather access to all inlets, pipe openings, flow control structures 	Required		

Inspection and Maintenance Action Checklist		Underground Structures*		
	<ul style="list-style-type: none"> Private facilities must have unrestricted access that is traversable by maintenance vehicles during dry months. 			

*The Underground Structures Checklist applies and must be included for facilities that incorporate the following BMPs:

- Underground Retention BMP: eg. Soakage trench
- Detention (Flow Control) BMP: eg. Detention pipes, vaults, chambers,

Inspection and Maintenance Action Checklist		Outlet Control Structures/Flow Restrictors*		
PROHIBITIONS				
<ul style="list-style-type: none"> Cannot open valves on stormwater facility structures. 				
Conditions to Check For	Action	Required/Suggested	Inspection Date	Maintenance Needed (if none, state none needed)
Sediment, debris, or trash is blocking or sump is less than 50% from restrictor/orifice plate	Remove and dispose.	Required		
<ul style="list-style-type: none"> Structural integrity. <ul style="list-style-type: none"> Tee-type flow restrictor is not securely attached to manhole wall and outlet pipe. Weir or baffle flow restrictor not securely attached to manhole. Flow restrictor is not plumb within 10% Connections to outlet pipe are leaking and show signs of rust Holes in plates, baffles, elbows, etc. 	<ul style="list-style-type: none"> Determine best method for anchoring flow restrictor based on materials and severity of situation. Replumb and realign restrictor, securing as necessary. Repair or replace as necessary to eliminate leakage. Plug or patch holes if structural integrity is not affected. Replace part if possible, replace entire structure if severely failing. 	Required		
Trash, sediment, or debris blocking overflow pipe.	Remove and dispose.	Required		

*The Outlet Control Structures/Flow Restrictors Checklist applies and must be included for any facility that incorporates the following:

- Outlet Control Structure:** Located at the downstream end of a stormwater facility, it controls the rate at which stormwater can flow out through the use of a flow restrictor.
- Flow Restrictor (Orifice, weir, undersized pipe, etc...):** A designed restriction specifically sized and placed to control stormwater outflow. A flow restrictor can come in the form of a hole (orifice) cut into a plate or pipe, a notch (weir), or an undersized pipe.

Inspection and Maintenance Action Checklist		Culverts/Pipes/Underdrains*		
Conditions to Check For	Action	Required/Suggested	Inspection Date	Maintenance Needed (if none, state none needed)
Trash, debris, or sediment restricting pipe flow.	Remove to maintain adequate conveyance at all times.	Required		
Damage to pipe such as rusting through wall of pipe, dents, bent or crushed ends that affect efficient flow.	Repair or replace pipe as necessary.	Required		
Cracking or buckling of headwall. Erosion or bypassing occurring at backside or around ends of headwall.	Determine extent of problem and monitor for changes. Repair or replace as necessary.	Required		
Missing rock or riprap within upstream or downstream apron areas or side slopes. Active erosion within area.	Repair eroded areas as necessary. Determine cause of rock movement and replace with similar size rock or larger as necessary.	Required		

*The Culverts/Pipes/Underdrains Checklist applies and must be included for any facility that incorporates underdrains, culverts, or pipes specifically for Retention, Treatment, or Detention of stormwater and does not apply to on-site conveyance pipes or catch basins.

Inspection and Maintenance Action Checklist			Vegetated Roofs	
PROHIBITIONS				
<ul style="list-style-type: none"> Pesticide use in stormwater facilities is prohibited. 				
Conditions to Check For	Action	Required/Suggested	Inspection Date	Maintenance Needed (if none, state none needed)
Damaged membrane	Repair or replace.	Required		
Clogged Drains	Remove sediment and debris.	Required		
Vegetation covers < 90% of roof surface	Possible Ways to achieve 90% vegetation cover: <ul style="list-style-type: none"> Determine if irrigation system is functioning properly. Have a soil fertility test done to determine if nutrient addition is needed, if so add compost. Add mulch around plantings. Revegetate following approved landscape plan to achieve at least 90% coverage. Remove and replace per approved landscape plan. Irrigate, if planting in the summer. 	Required		
Erosion	Fill eroded area with approved soil, plant to prevent erosion.	Required		
Standing Water	Check for leaks in irrigation, clear drains, amend soils to restore infiltration.	Required		

STORMWATER FACILITY MAINTENANCE RECORD

Use this record to document inspections. Keep invoices and work orders for maintenance work on file and provide upon request of the approving agency.

Stormwater Facility Type:			
Facility Address:			
Business Name:			
Responsible Party for maintenance:		Position:	
	Phone:	Email:	
Organization:			

Issue	Actions Taken	Date Action Taken	Work approved by:
Issue	Actions Taken	Date Action Taken	Work approved by:

Appendix I – Rogue Valley Sewer Services Stormwater Credits

TABLE OF CONTENTS

Appendix I - Rogue Valley Sewer Services Stormwater Credits..... 1

 Introduction 1

 Volume Control 1

 Trees..... 1

 Combined Credit 2

 RVSS STORMWATER QUALITY MANAGEMENT FEE CREDIT WORKSHEET 3

Appendix I - Rogue Valley Sewer Services Stormwater Credits

INTRODUCTION

Rogue Valley Sewer Services (RVSS) collects a monthly stormwater quality management fee of \$1 for a single family residence. Multi-family residences, commercial, and industrial uses are charged \$1 per 3,000 square feet of impervious area. RVSS code specifies that properties that take measures above and beyond the minimum requirements to protect water quality are entitled to a reduction in the monthly stormwater quality management fee. Two methods for earning credits are described below. The onus of demonstrating that a property is entitled to stormwater credit is on the property owner and is subject to review and approval by RVSS. Stormwater credits cannot reduce the monthly rate below the base rate for a single family home. Stormwater credits do not negate the need for Retention or Treatment per Section 2.4.

In addition to Stormwater credits on the monthly fee, incentive funding is available to cover engineering and construction costs associated with going above and beyond the requirements of the Rogue Valley Stormwater Quality Design Manual (Design Manual). Information on incentive funding can be found on RVSS' website.

VOLUME CONTROL

The Rogue Valley Stormwater Quality Design manual requires flow control measures to prevent an increase in the *peak runoff* from a property. The Design Manual does not require limitations on the *total volume* of stormwater runoff from a property. However, credit for volume control can be earned by reducing the total volume of stormwater that flows off of the subject property. This can be done for the total volume of runoff through Retention, as defined in the Design Manual, or Detention. To qualify for this credit, the applicant must show the calculated peak runoff both with and without volume control measures. The total credit is equal to the percentage reduction in runoff volume over 24-hours using the 10-year event design storm, Section 2.5.

Example 1: A 10-acre commercial facility has 5-acres of impervious surface area. The monthly charge would be \$72.60 with no volume control. The calculated total runoff during a water quality design storm is 38,738 cubic feet in 24-hours. The property owner designs the stormwater system to retain and infiltrate 10,000 cubic feet per day which reduces the total runoff volume by 25.8%. The reduced monthly fee is $\$72.60 \times (1 - 0.258)$, or \$53.87.

Example 2: The same 10-acre commercial facility instead decides to install an extended detention basin with a maximum outflow of 0.30-cfs. The average daily runoff for the property is 0.45-cfs. The extended detention basin is therefore a 66.6% reduction in runoff over 24-hours which qualifies the project for a credit equal to 33.3% of the monthly charge. The total monthly charge would therefore be $\$72.60 \times (1 - 0.333)$, or \$48.42.

TREES

The amount of impervious surface area used to calculate the monthly fee can be reduced through protection of some existing tree cover and by planting new trees. Tree credits can amount to a maximum of 25% of the total impervious surface area. Calculations for determining the impervious area reduction associated with trees are shown in the worksheet below.

Example 3: A 2-acre commercial facility will have 60,000 square feet of impervious surface area, which would result in a \$20 per month service charge. As part of their development plan they are able to preserve 10,000 square feet of existing tree canopy, all within 30-feet of the impervious surface. They are also planting 30 evergreen trees and 30 deciduous trees as part of their landscaping plans. The reduction in impervious area calculated for the fee is as follows:

Area of Protected Existing Tree Canopy $10,000 \text{ SF} \div 2 = 5,000 \text{ SF}$

Number of new Deciduous Trees	$30 \times 100 \text{ SF} = 3,000 \text{ SF}$
Number of new Evergreen Trees	$30 \times 200 \text{ SF} = 6,000 \text{ SF}$
Total Area Reduction for Tree Credit	$= 14,000 \text{ SF}$

The full Stormwater credit applies since the calculated tree credit area (14,000 SF) is less than 25% of the total impervious surface area.

$$(60,000 \text{ SF} * 0.25 = 15,000 \text{ SF}),.$$

The impervious surface used to calculate the monthly fee will be:

$$60,000 \text{ SF} - 14,000 \text{ SF} = 46,000 \text{ SF}$$

The total monthly fee would be \$15.33.

$$\$1 * (46,000 \text{ SF} / 3,000 \text{ SF}) = \$15.33 .$$

COMBINED CREDIT

Both volume control credit and tree credit can apply to the same property. When this happens, each credit is calculated independently and is added together for the total credit.

Example 4: A 5-acre development has 3-acres (130,680 SF) of impervious surface, which creates 22,000 cubic feet per day of runoff during a 10-year storm. The standard monthly stormwater quality fee would be \$43.56.

$$\$1 * (130,680 \text{ SF} / 3,000 \text{ SF}) = \$43.56$$

The project uses an extended detention basin with a maximum outflow of 0.17 cubic feet per second, which is 66.6% of the average daily runoff. The assessed impervious area would be reduced by 33.3%, or 43,516 SF. The project also preserves existing trees and plants new trees, as in Example 3, for a tree credit area reduction of 14,000 SF. The total assessed area is calculated below:

Impervious Surface Area	130,680 SF
Volume Control credit	- 43,560 SF
Tree credit	<u>14,000 SF</u>
Assessed Impervious Surface Area	73,120 SF

By taking these measures, the monthly stormwater quality fee would be reduced from \$43.56 to \$24.37 ($\$1 * (73,120 \text{ SF} / 3,000 \text{ SF})$), a monthly savings of \$19.19.

RVSS STORMWATER QUALITY MANAGEMENT FEE CREDIT WORKSHEET

The standard stormwater quality management fee is \$1 per 3,000 square feet of impervious surface on the site. This fee may be reduced by limiting the volume of stormwater that leaves the site in 24-hours or by planting new trees and protecting existing tree canopy. NOTE: Units are in square feet (SF) and cubic feet per day (CF/DAY).

- A. Total Site Area _____ SF
- B. Total Impervious Area _____ SF
- C. Monthly Stormwater Base Rate $B \times \$1 \div 3,000 \text{ SF} =$ \$ _____

VOLUME CONTROL CREDIT

- D. Calculated Runoff with no Volume Control _____ CF/DAY
- E. Calculated Runoff with Volume Control _____ CF/DAY
- F. Percent Reduction from Volume Control $E \div D =$ _____ %
- G. Assessed Impervious Surface Reduction $B \times (1 - F) =$ _____ SF

TREE CREDIT

- H. Area of Protected Existing Tree Canopy _____ SF $\div 2 =$ _____ SF
- I. Number of new Deciduous Trees _____ $\times 100 \text{ SF} =$ _____ SF
- J. Number of new Evergreen Trees _____ $\times 200 \text{ SF} =$ _____ SF
- K. Total Area for Tree Credit $H + I + J =$ _____ SF
- L. Maximum Credit Allowable $B \times 0.25 =$ _____ SF
- L. Smaller of K or J _____ SF

TOTAL STORMWATER CREDIT

- M. Total Impervious Area (B) _____ SF
- N. Volume Control Credit (G) _____ SF
- O. Tree Credit (L) _____ SF
- P. Assessed Impervious Area $M - N - O =$ _____ SF
- Q. Adjusted Stormwater Fee $P \times \$1 \div 3,000 \text{ SF} =$ \$ _____